



**Table of Contents**

**FEA-0024**

**Tools & Parts**

Assembly Requirements..... 1

ErgoRack Rotation Feature / FEA-0024..... 2

Rotation Hardware Kit / HKT-842 ..... 3

FEA-0024 Rotation Module Overview ..... 4

Universal ErgoRack Service Part Assembly..... 5

**System Installation**

Rear Crossbar Rotation Assembly ..... 6

Cylinder & Hardware..... 7

Front Crossbar Rotation Assembly..... 8

Front Auto Clamp & L-post..... 9-10

Front Z-post ..... 11

Rear L-post..... 12

Rear Z-post ..... 13

Rear Rotation Bushings ..... 14

Front Rotation Bushings..... 15



**Assembly Requirements**

**FEA-0024**



**INSTALLER NOTE:** It is important to correctly follow these assembly instructions. These instructions for assembly are provided by the manufacturer at time of ErgoRack delivery, and reflect the technical specifications applicable at the time of writing.

- These instructions are subject to change if the manufacturer revises the parts and/or production of the subsystems and accessories used in the brand's vehicles. Following the instructions for assembly will ensure proper installation of the product. The manufacturer will not be held liable if these instructions are not followed.
- The addition of parts and/or components not original to this ErgoRack are discouraged. Use only OEM supplied parts.
- Consultation of the OEM vehicle may be required during assembly to avoid vehicle damage. Ensure bolt locations will not damage any critical parts of the vehicle—i.e. gas tank, wiring harnesses, or hoses-before drilling.



5 MM Hex Key Socket

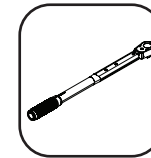

Torque Wrench



Ratcheting Wrench



13 MM Socket



## INSTALLATION INSTRUCTIONS

ErgoRack

ITEM	DESCRIPTION	QTY
1	SLIDE ASSEMBLY	1
2	DRIVE ARM ASSY	2
3	ROTATION ARM ASSY	2
4	UNIVERSAL UPPER FRONT W CAPS AND BUSHINGS	1
5	AUTO CLAMP ASSY	1
6	Z POST BRACKET ASSY, ADJUSTABLE, 7.25"	1
7	DAMPER, HYDRAULIC, ER, 2020	1
8	L POST ASSY G4 AC CAP SGL 2 SECTION	1
9	Z POST CLAMP BRACKET NARROW SLIDE ADJ	1
10	Z POST, ADJUSTABLE, 6.50", PADDED	2
11	L POST ASSY G2 SPECIAL SQ CAP SGL 2 SEC	1
12	SLIDE ROTATION HARDWARE KIT	1
13	BOX, L(35") X W(9") X D(6")	1
14	BOX TEMPLATE UNIVERSAL SLIDE FEATURE BOTTOM	1
15	BOX TEMPLATE UNIVERSAL SLIDE FEATURE TOP	1
16	LABEL BLUE 4IN X 6IN FEA-0024 BOX	2

For a list of replacement parts, see page Vii.

## ErgoRack Rotation Feature / FEA-0024

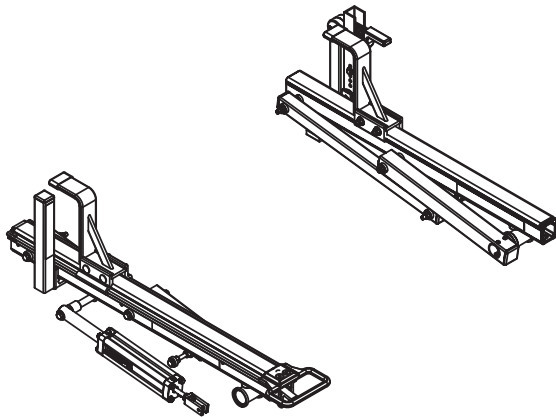
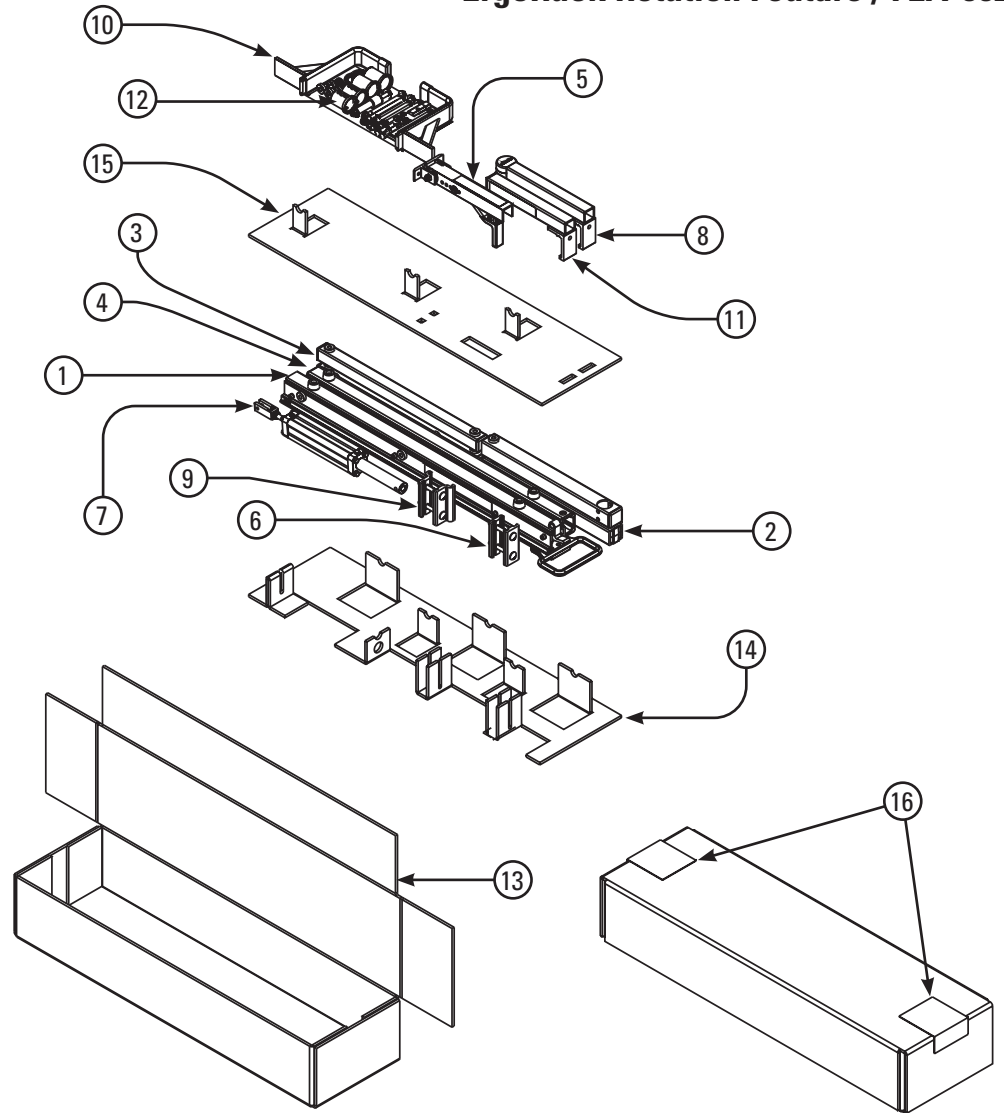





**INSTALLATION INSTRUCTIONS**

ErgoRack

ITEM	PRODUCT	APPROX. DIM.
A	ROTATION LENGTH	30.50"
B	ROTATION HEIGHT	13'
C	CROSSBAR SPACING	4'-8'

**FEA-0024 Rotation Module Overview**  
Shown with Crossbars for illustrative purposes only

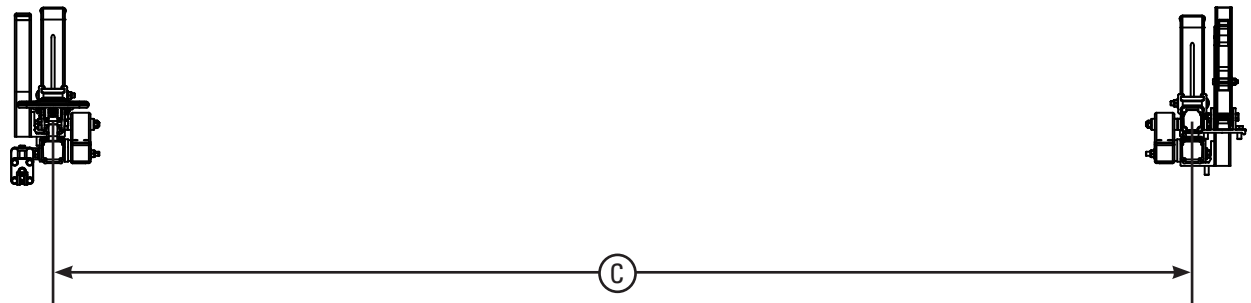
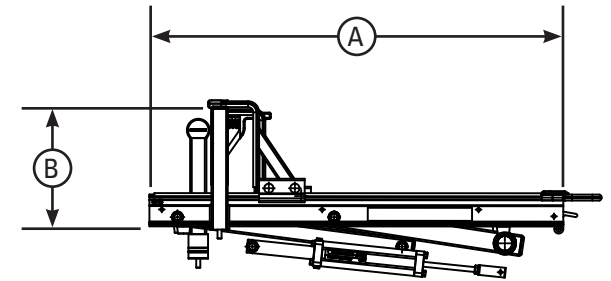
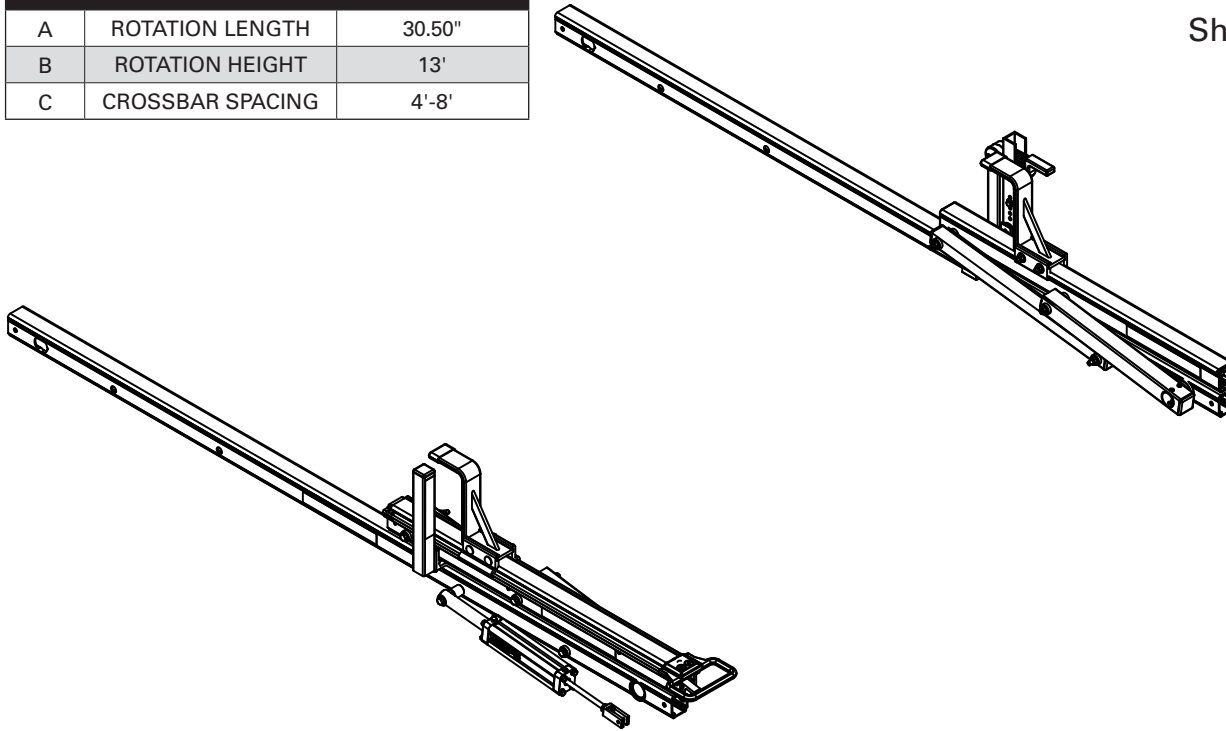



## INSTALLATION INSTRUCTIONS

## Universal ErgoRack Service Part Assembly

ITEM	PART #	DESCRIPTION	QTY
1	RKT-8000	REPLACEMENT KIT - UPPER	2
2	RKT-8001	REPLACEMENT KIT - SLIDE UPPER	2
3	RKT-8002	REPLACEMENT KIT - G6 DRIVE ARM	4
4	RKT-8003	REPLACEMENT KIT - ROTATION ARM	4
5	RKT-8004	REPLACEMENT KIT - FRONT Z POST W CLAMPS	2
6	RKT-8005	REPLACEMENT KIT - SLIDE L POST	2
7	RKT-8006	REPLACEMENT KIT - AUTOCLAMP	2
8	RKT-8007	REPLACEMENT KIT - AUTOCLAMP L POST	2
9	RKT-8008	REPLACEMENT KIT - G6 SLIDE Z POST	2
10	RKT-8009	REPLACEMENT KIT - G6 REAR DS WITH HEX	2
11	RKT-8010	REPLACEMENT KIT - G6 FRONT DS [36 IN]	1
12	RKT-8012	REPLACEMENT KIT - CONNECTING BAR [60IN]	1
13	RKT-8013	REPLACEMENT KIT - CONNECTING BAR [36IN]	1
14	RKT-8011	REPLACEMENT KIT - G6 FRONT DS [24 IN]	1
15	ACL-125	HYDRAULIC CYLINDER ASSY W HRDWR	2
16	HKT-8210	HARDWARE KIT - G6 ROTATION BOLT	2
17	HKT-8211	HARDWARE KIT - G6 DRIVE SHAFT KIT	2
18	HKT-8212	HARDWARE KIT - CROSSBAR CAPS	1

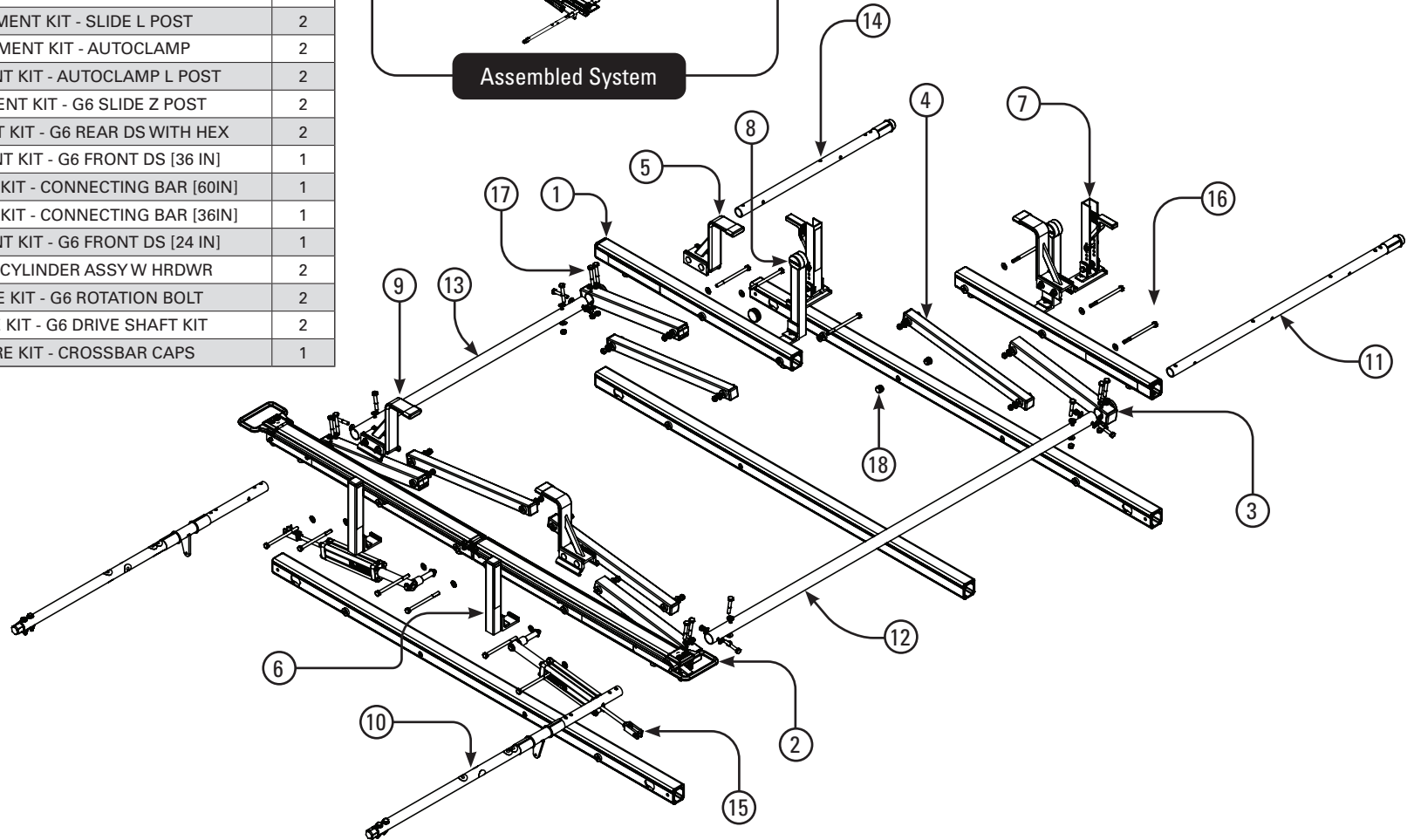
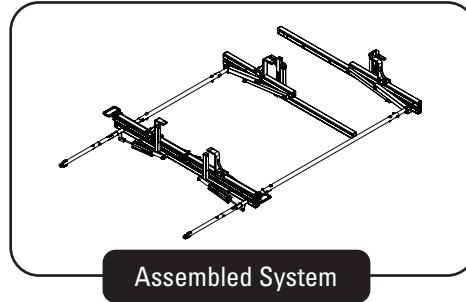



**INSTALLATION INSTRUCTIONS**

**Rear Crossbar Rotation Assembly**

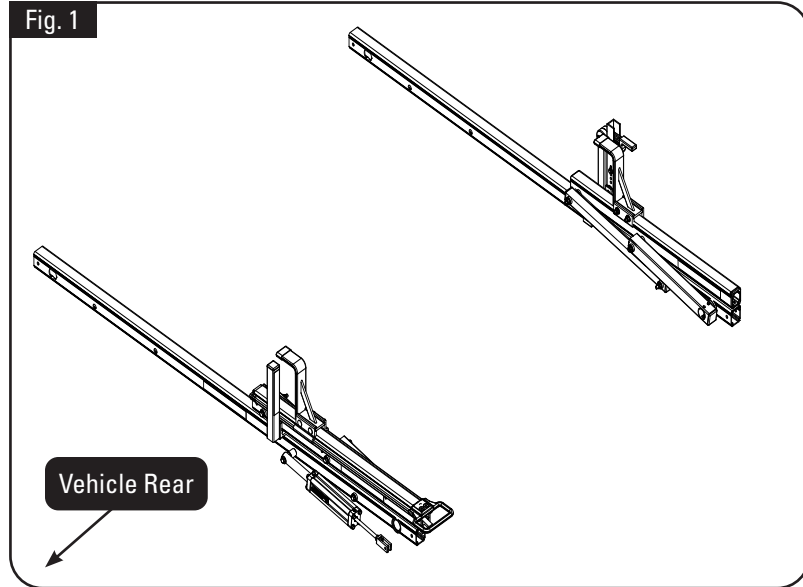

**Installation page Note:** For ease of installation, it's recommended to assemble any Rotations onto the Crossbars before placing them onto the FBM's mounting brackets. The use of a helper is recommended when placing built Crossbars onto the vehicle.

**Note:** This Rotation Kit fits both right side and left side. To install on the left side, mirror these (FEA-0024) right side installation instructions (Fig. 1).

**Step 1:** Using M8 x 120mm Hex Head Bolt in hardware kit, attach Drive Arm & Rotation Arm onto slide upper (Fig. 2).

**Step 2:** Using M8 x 120mm Hex Head Bolt in hardware kit, attach Slide Assy with Rotation Arm onto crossbar (Fig. 3).

**Step 3:** Torque all bolts to 55 in-lbs (Fig. 4).

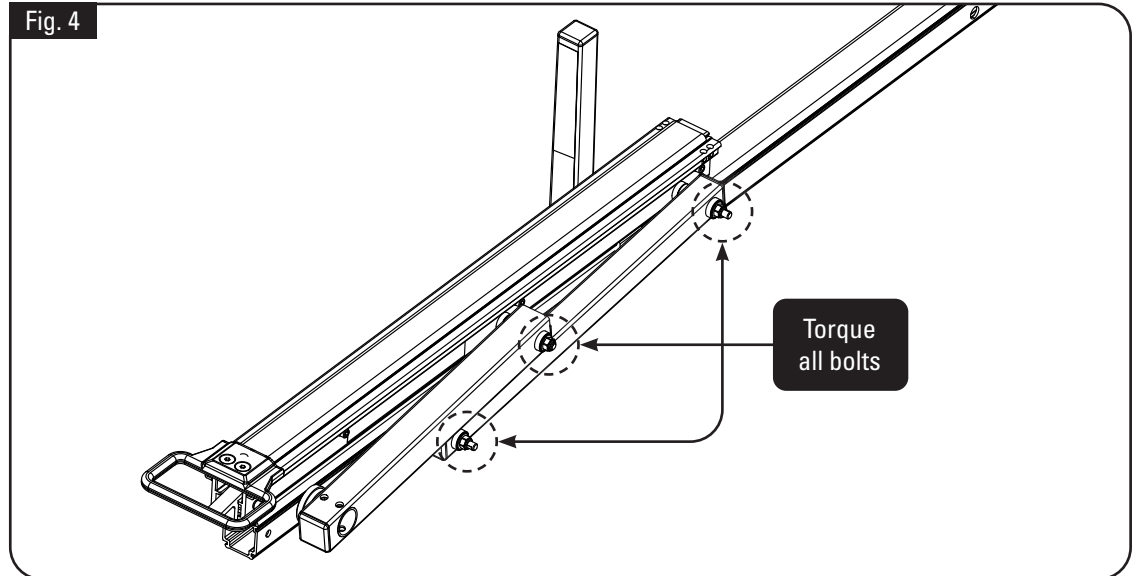
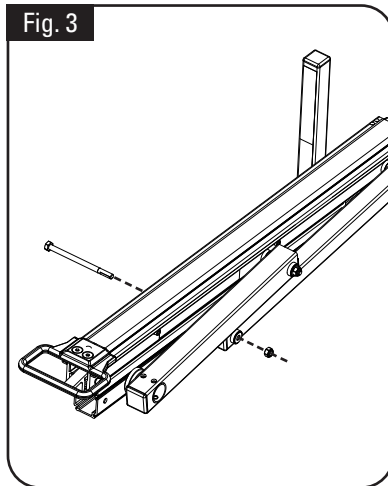
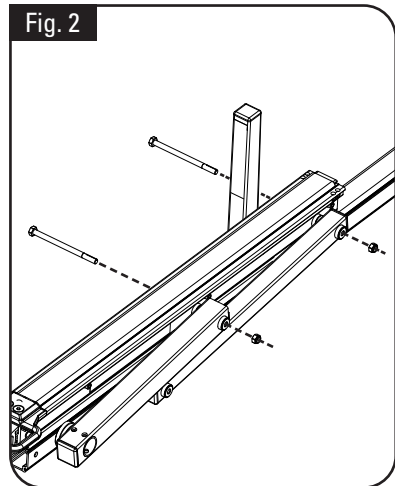





**INSTALLATION INSTRUCTIONS**

**Cylinder & Hardware**

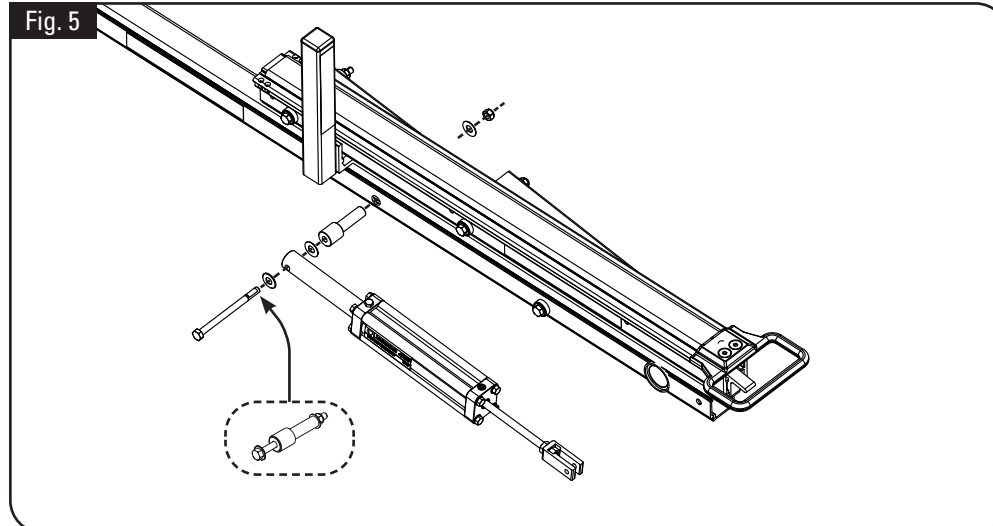

**Step 4:** Using Cylinder Bolt Assembly-M8 in hardware kit, attach Cylinder to crossbar (Fig. 5).

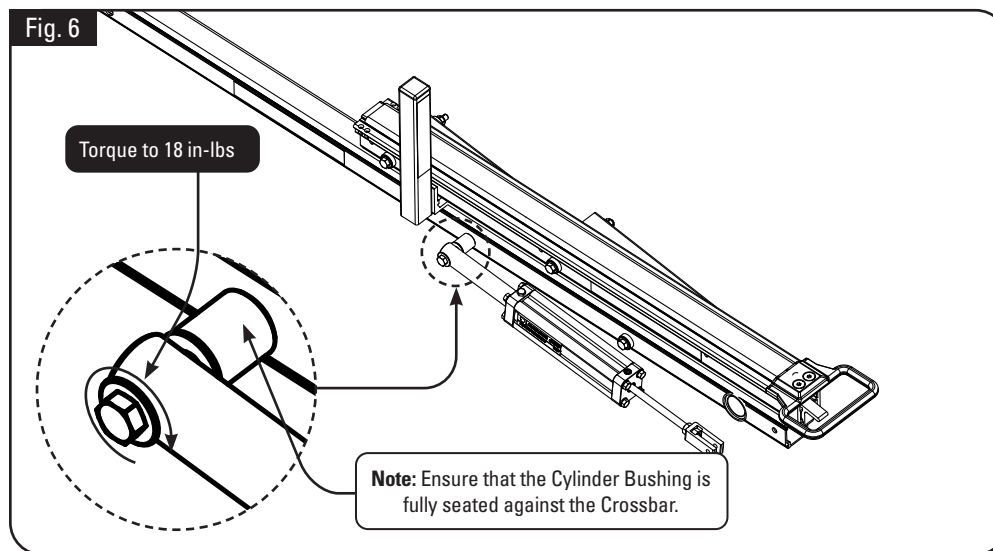

**Step 5:** Torque bolt to value of 18 in lbs (Fig. 6).



**INSTALLATION INSTRUCTIONS**

**Front Crossbar Rotation Assembly**

Fig. 7

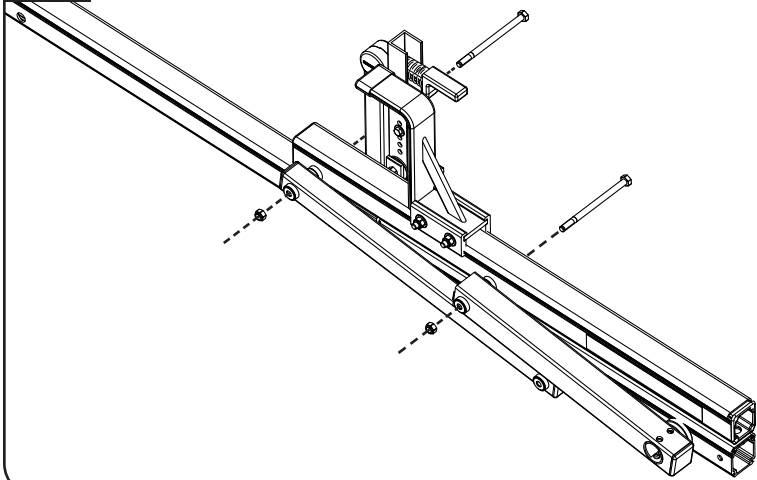

**Step 6:** Using M8 x 120mm Hex Head Bolt in hardware kit, attach Drive Arm & Rotation Arm onto slide upper (Fig. 7).

**Step 7:** Using M8 x 120mm Hex Head Bolt in hardware kit, attach Slide Assy with Rotation Arm onto crossbar as shown (Fig. 8).

**Step 8:** Torque all bolts to 55 in-lbs (Fig. 9).

Fig. 8

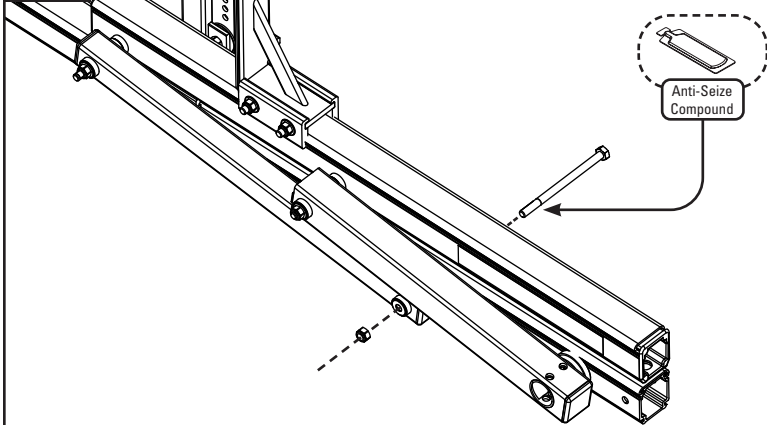
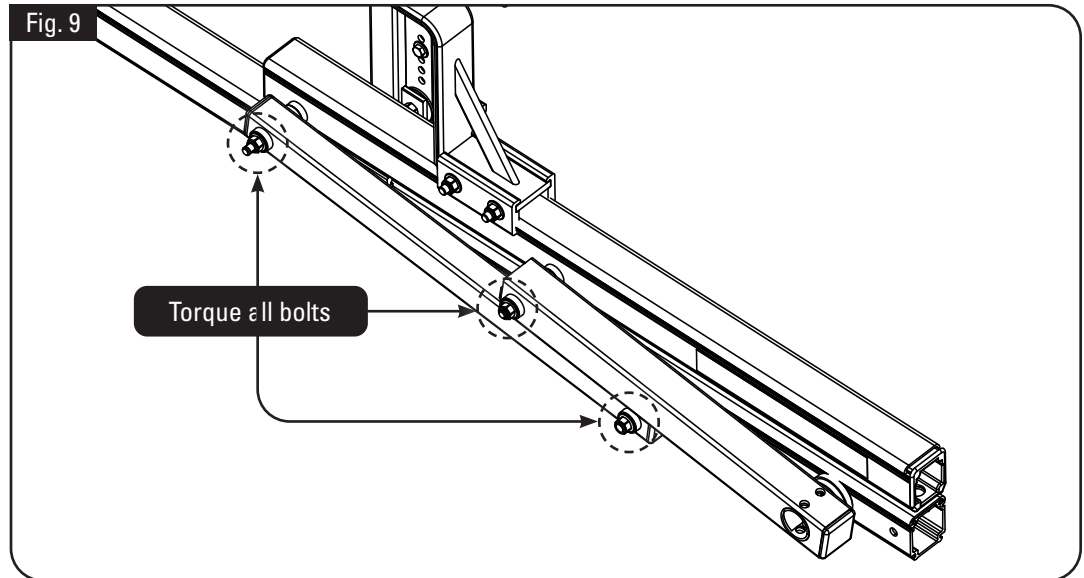

Fig. 9





**INSTALLATION INSTRUCTIONS**

**Front Auto Clamp & L-post**

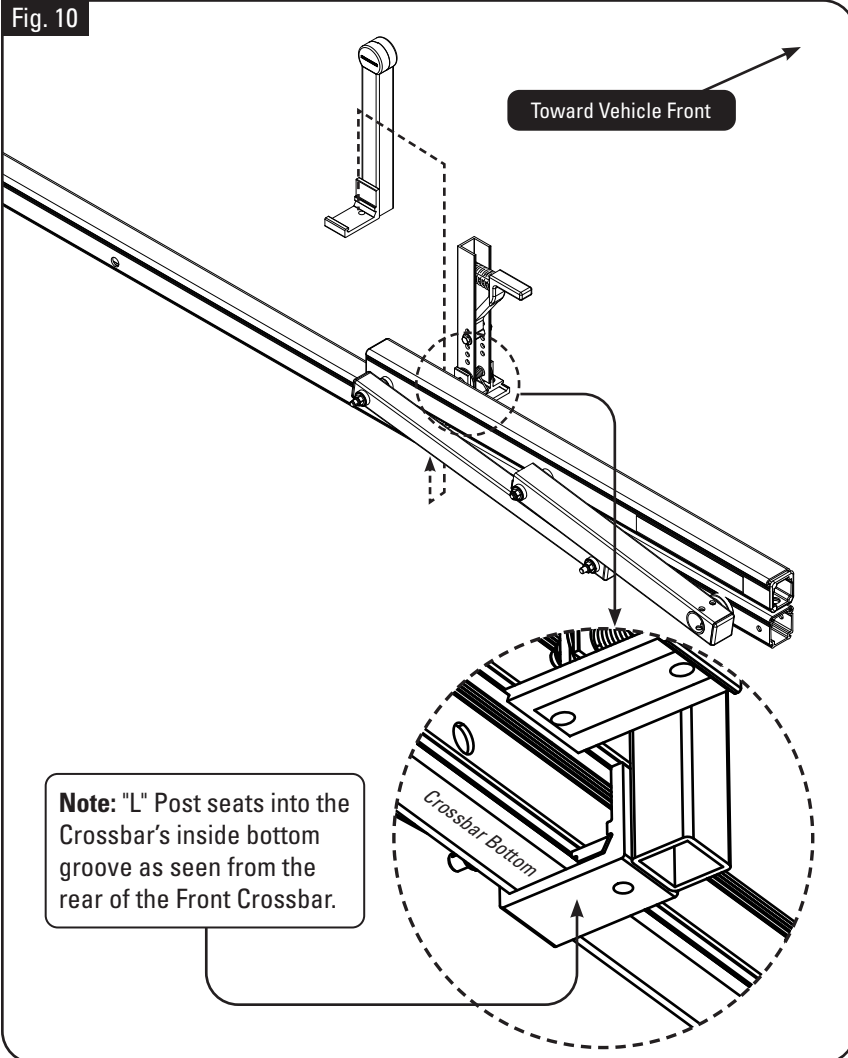

**Step 9:** Place an "L" Post into the bottom groove of the Front Crossbar (Fig. 10).

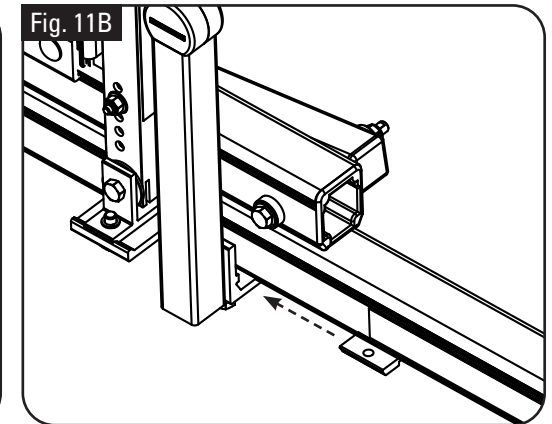
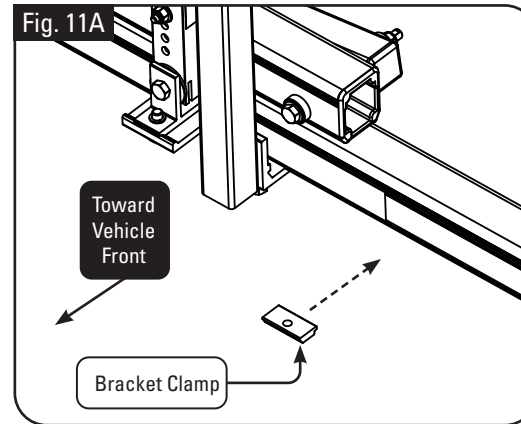

**Step10:** Slide L Post Bracket Clamp into bottom groove, then slide into L Post Connector (Fig. 10A & B). **Note:** The orientation of the bolt hole faces away from the Crossbar.

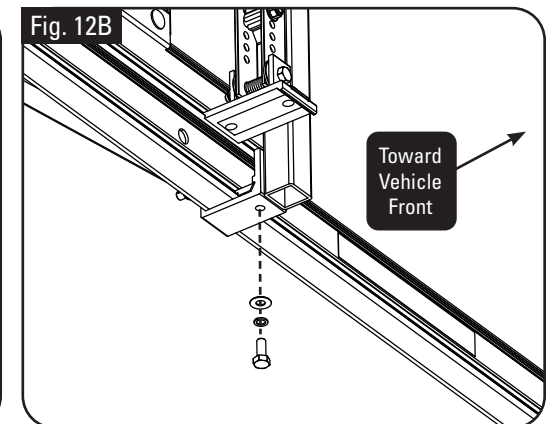
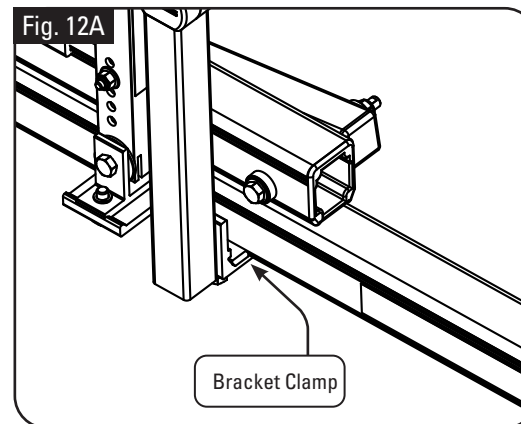

**Step11:** Bracket Clamp sits in L Post Connector Clamp (Fig. 12A).

**Step 12:** Assemble the L Post hardware (Fig. 12B).



**INSTALLATION INSTRUCTIONS**

**Front Auto Clamp & L-post (Continued)**

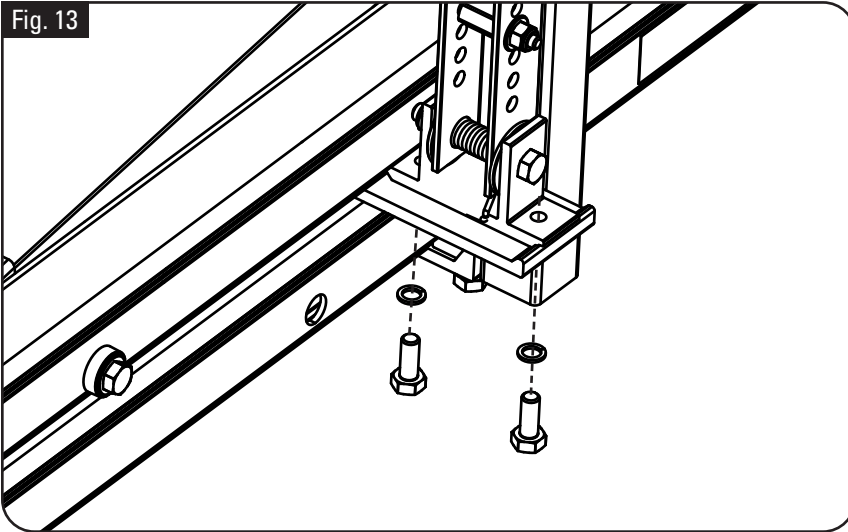

**Step 10:** Loosely Install Auto Clamp (FEA-0024 print #5) onto upper using the following hardware in hardware kit: #13 - Auto Clamp Base, #4 - Flat Washer, #11 - Lock Washer, & #3 - M8 X 20 MM Bolt (Fig. 13).

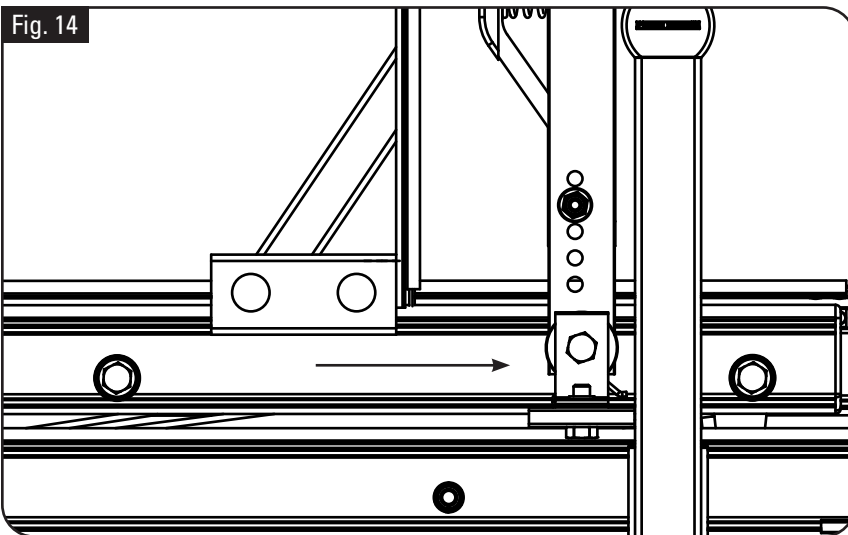

**Step 11:** Position Auto Clamp directly against L-post to align. Tighten and torque bolts to 55 in-lbs. (Fig. 14).



**INSTALLATION INSTRUCTIONS**

**Front Z-post**

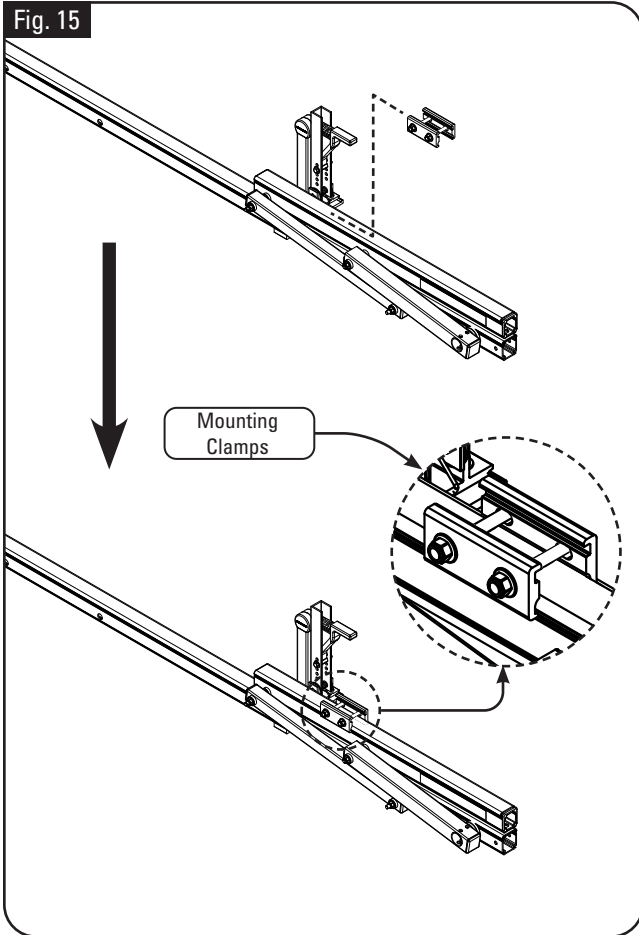

**Step 12:** Assemble the Z Post Mounting Clamp Assembly onto the Rotation Upper (Fig. 15). The Mounting Clamps seat fully into the top groove of the Upper.

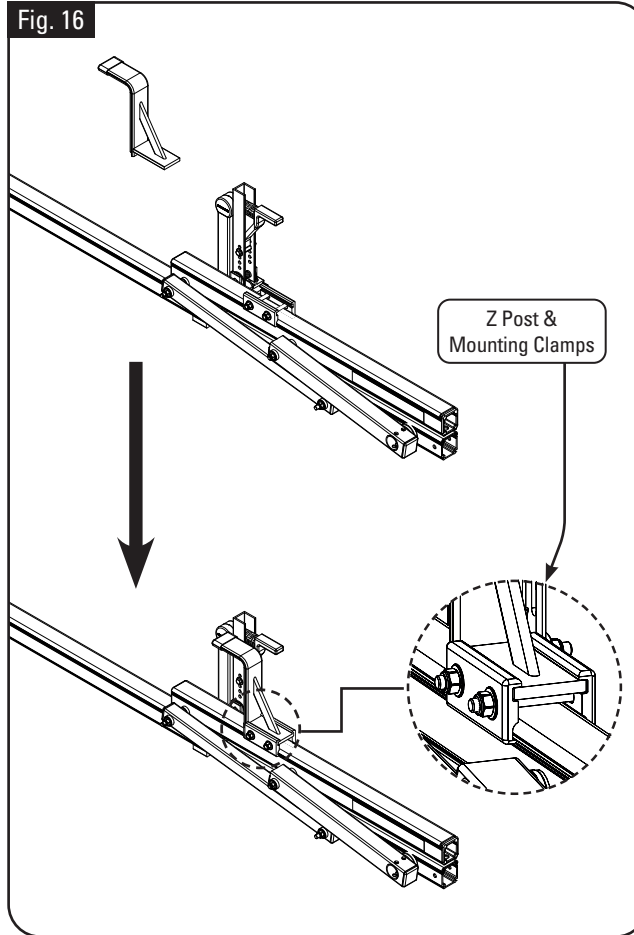

**Step 13:** Slide the Z Post into the Mounting Clamp Assembly (Fig. 16). The Z Post fully seats into the top slot of the Mounting Clamps.

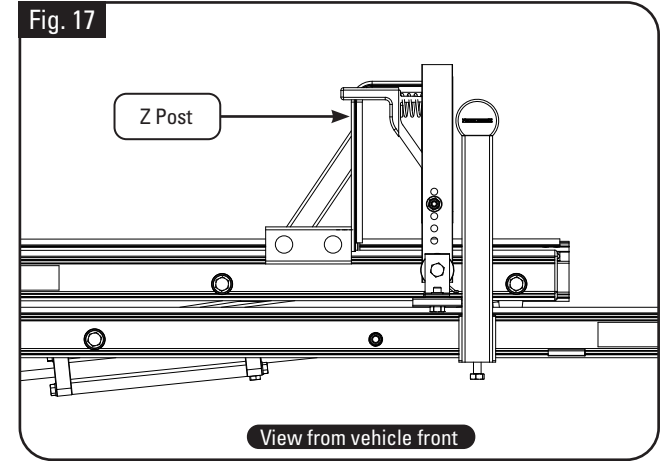

**Step 14:** Refer to the Quick Start Guide for Z Post positioning (Fig. 17).

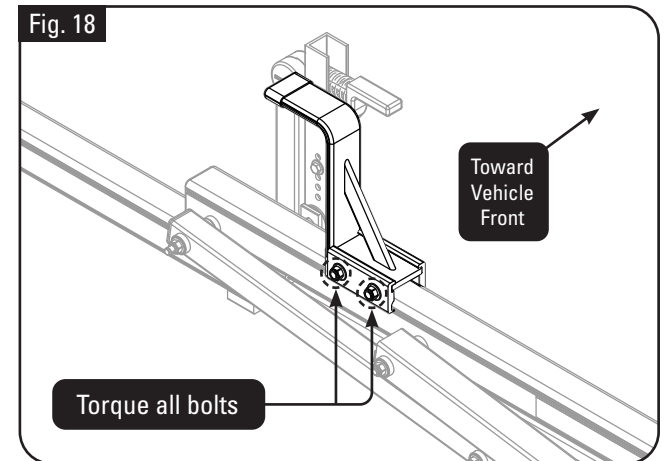

**Step 15:** Torque to 90 in-lbs (Fig.18).



**INSTALLATION INSTRUCTIONS**

**Rear L-post**

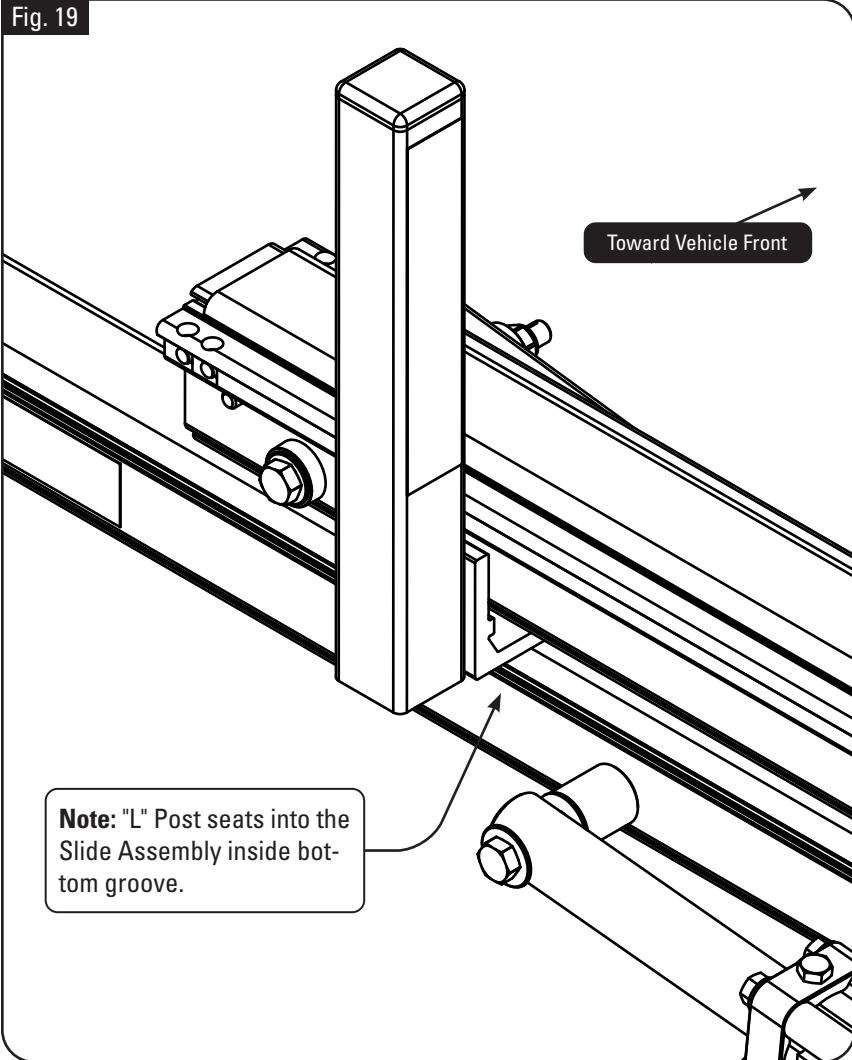

**Step 16:** Place an "L" Post into the bottom groove of the Slide Assembly (Fig. 19).

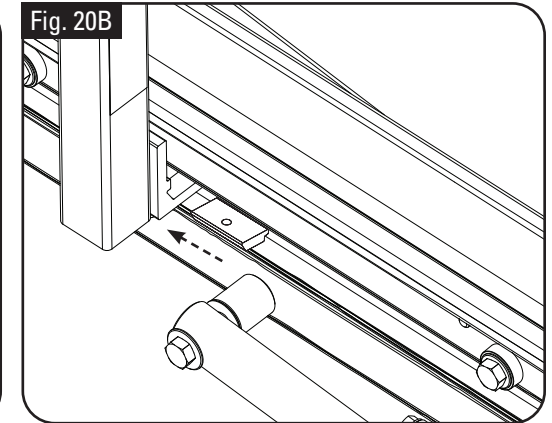
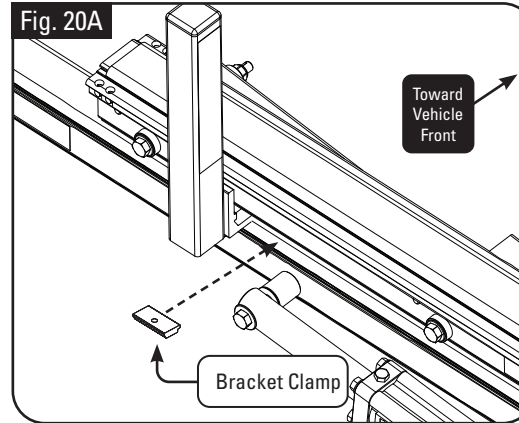

**Step 17:** Install L-post (FEA-0024 Print #11) onto bottom of slide assembly using the following hardware in hardware kit: #12 - Clamp Bracket M8, #4 - Flat Washer, #11 - Lock Washer, & #3 - M8 X 20 MM Bolt (Fig. 20A & B).

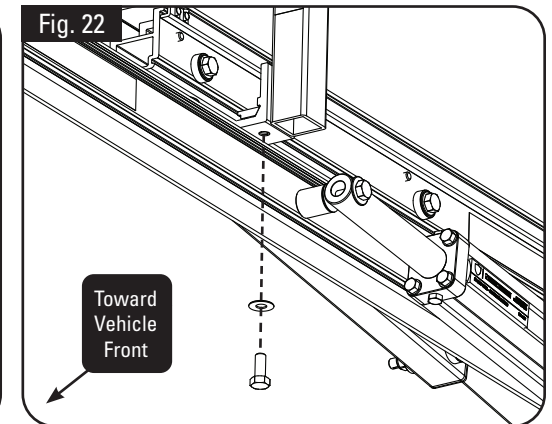
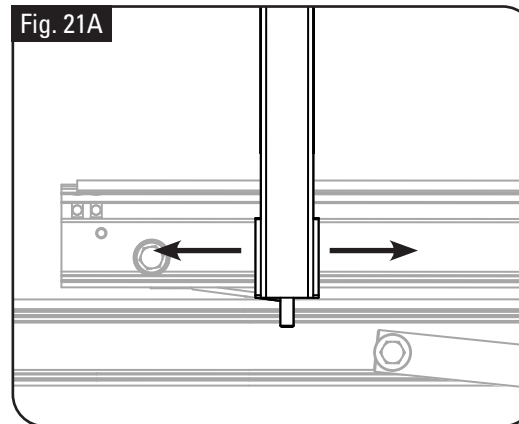

**Step 18:** Position on upper according to desired location for ladder being carried (Fig. 21).

**Step 19:** Torque to 90 in-lbs (Fig. 22).



**Rear Z-post**

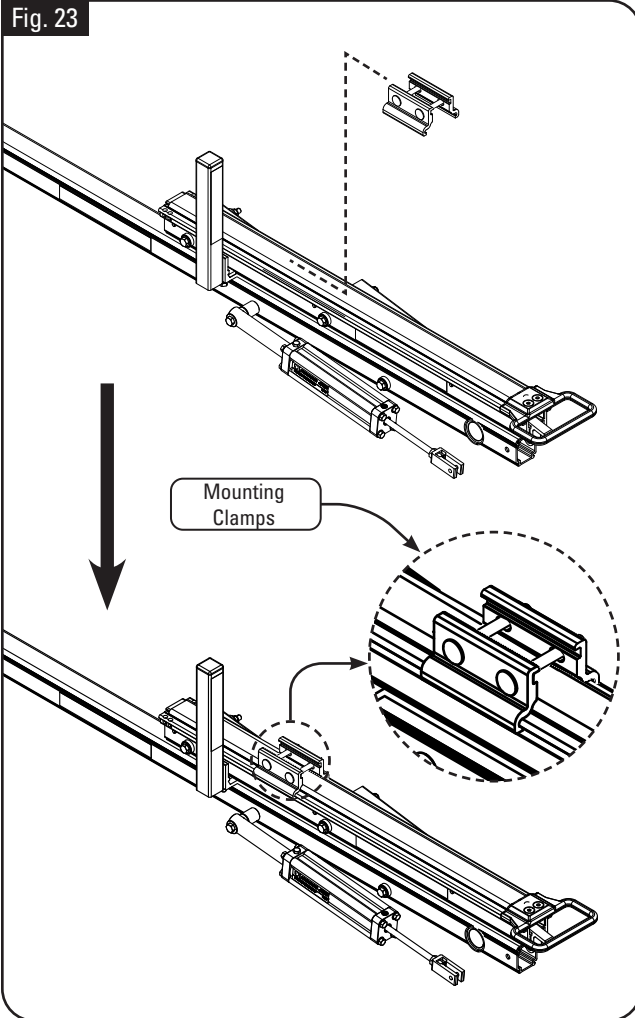

**Step 20:** Install Z-post mounting clamp assembly onto upper in orientation shown (Fig. 23).

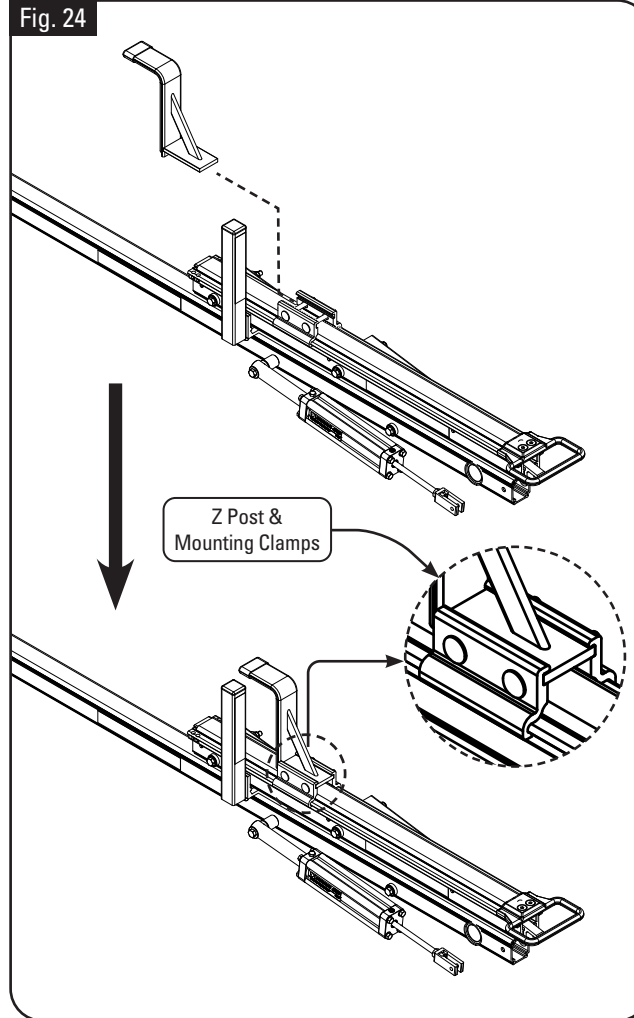

**Step 21:** Slide Z-post into the mounting clamp assembly (Fig. 24).

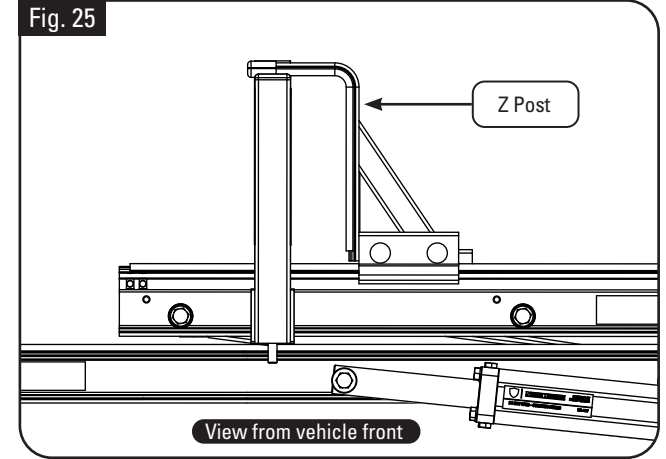

**Step 22:** Position on upper according to desired location for ladder being carried (Fig. 25).

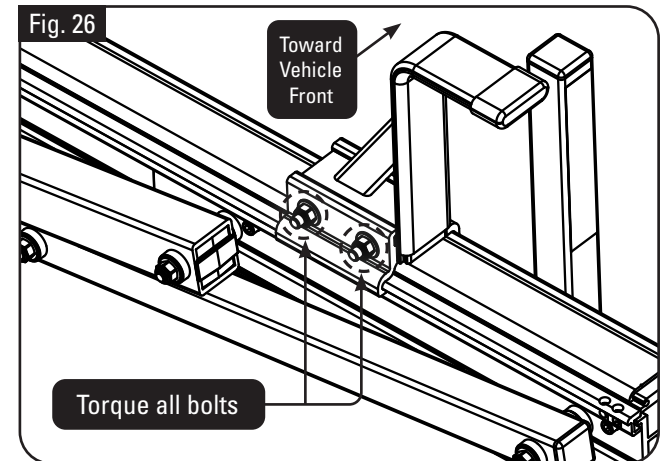

**Step 23:** Torque to 90 in-lbs (Fig.26).



**INSTALLATION INSTRUCTIONS**

**Rear Rotation Bushings**

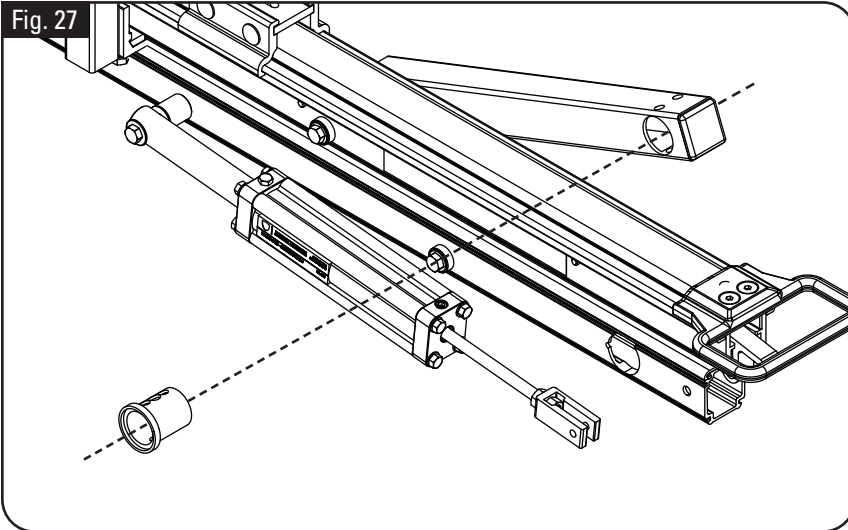

**Step 24:** Using Bushing, Drive Arm in the hardware kit, install bushing into drive arm with wider flange facing crossbar and holes aligned (Fig. 27).

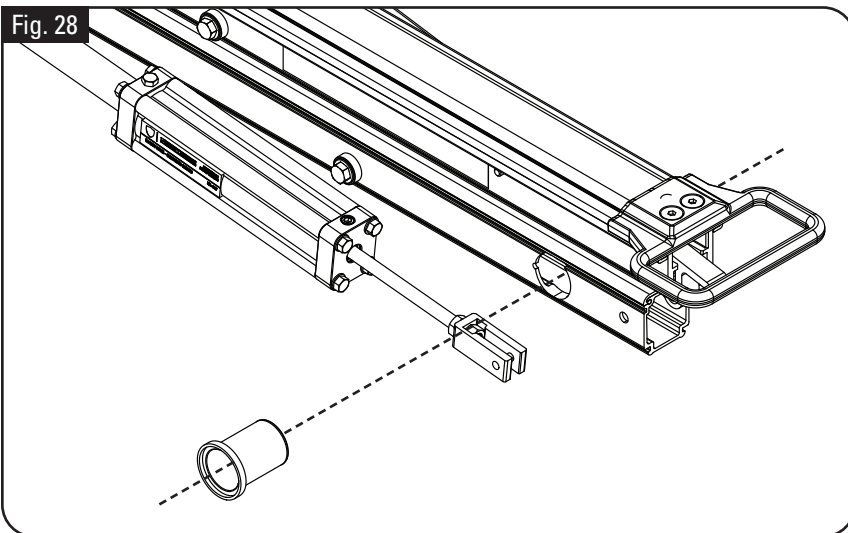

**Step 25:** Using Bushing, Large Drive Shaft (bushing without hole) in hardware kit, install bushing into crossbar from rear as shown aligning boss to crossbar notch (Fig. 28).

**Note:** Retain bushing spacers and lubricant from hardware kit (HKT-8423 Print #9 & #15) and install during driveshaft installation.





**INSTALLATION INSTRUCTIONS**

**Front Rotation Bushings**

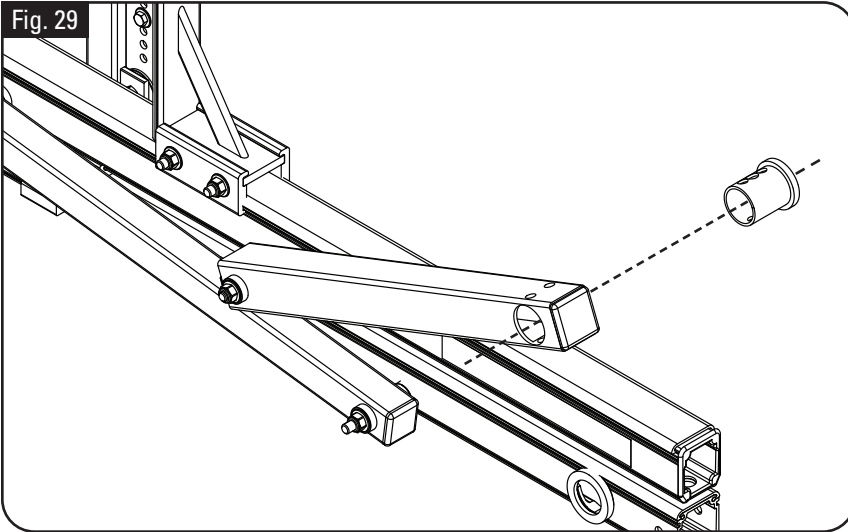

**Step 24:** Using BSH-3015 in hardware kit, install bushing into drive arm with wider flange facing crossbar and holes aligned (Fig. 29).

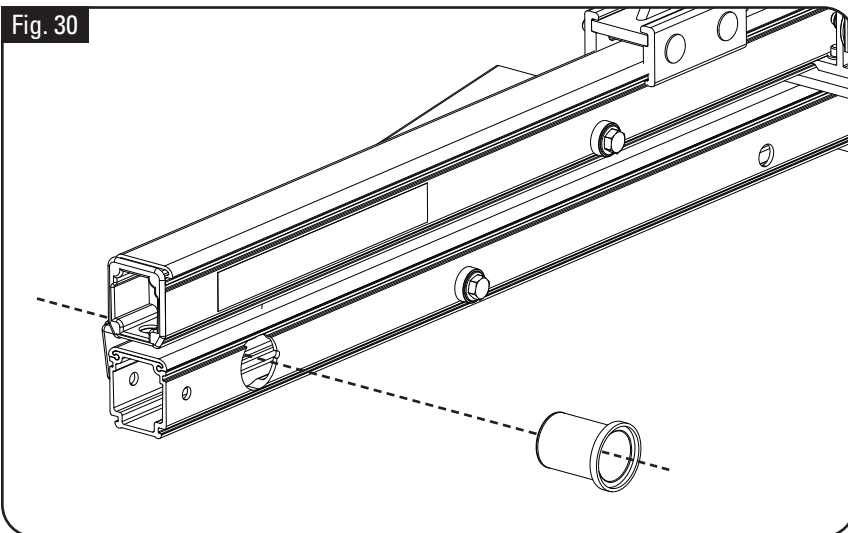

**Step 25:** Using Bushing, Large Drive Shaft (bushing without hole) in hardware kit, install bushing into crossbar from rear as shown aligning boss to crossbar notch (Fig. 30).

**Note:** Retain bushing spacers and lubricant from hardware kit (HKT-8423 Print #9 & #15) and install during driveshaft installation.