

2 Person Lift Recommended



Doc#: USAM-FPU3250-US01 REV A 0424

Revised: 05/29/24 WLH

PRIME DESIGN, A SAFE FLEET BRAND • WEBSITE: WWW.PRIMEDESIGN.NET • TM & © 2024 PRIME DESIGN. PROTECTED BY ONE OR MORE OF THE FOLLOWING PATENT NO.'S 6764268, 6971563, 8511525, 8991889, 9102482, 9415726, 9481314, 9506292, 9776476, 9796340, 10470565, 10486608, 10501022, 10578182, 10654420, 10688937, 10836312 AND OTHER PATENTS PENDING



Table of Contents

FPU-3250

General Information

Assembly Requirements..... 1

Adjustable Upright Assembly [73] FPU-3250 / Rev. B 2

HKT-0272 Hardware Kit - FoldPro Upright Mounting (FRONT VIEW) 3

System Installation

Upright Pivot & Latch Installation - Transit High Roof 4

Upright Pivot & Latch Installation - ProMaster High Roof..... 5

Upright Pivot & Latch Installation - Sprinter & Transit Mid Roof 6

Upright Pivot & Latch Installation - ProMaster & Sprinter Low Roof..... 7

Upright Support Mounting Bracket Installation - All Models..... 8



Assembly Requirements



INSTALLER NOTE: It is important to correctly follow these assembly instructions. These instructions for assembly are provided by the manufacturer at time of FoldPro Shelving delivery, and reflect the technical specifications applicable at the time of writing.

- These instructions are subject to change if the manufacturer revises the parts and/or production of the subsystems and accessories used in the brand's vehicles. Following the instructions for assembly will ensure proper installation of the product. The manufacturer will not be held liable if these instructions are not followed.
- The addition of parts and/or components not original to this FoldPro Shelving are discouraged. Use only OEM supplied parts.
- Consultaion of the OEM vehicle may be required during assembly to avoid vehicle damage. Ensure bolt locations will not damage any critical parts of the vehicle—i.e. gas tank, wiring harnesses, or hoses-before drilling.

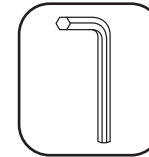

5 MM Allen Wrench / Socket

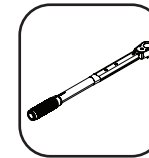

Torque Wrench w/ 13MM Socket



Ratcheting Wrench

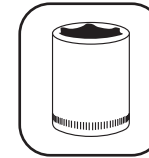

13 MM Socket

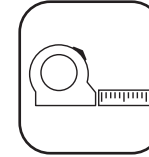

Tape Measure



INSTALLATION INSTRUCTIONS

FoldPro Shelving Uprights

ITEM	PART #	DESCRIPTION	QTY
1	AV-1180	FP ADJUSTABLE MAIN SUPPORT [73]	2
2	AV-1019	FOLDPRO SHELVING SUPPORT BOTTOM MOUNTING BRACKET	2
3	BOX-1140	BOX, L(77.25") X W(5.75") X D(7.00") / 1	1
4	HKT-0265	FP ADJUSTABLE MOUNTING PIVOT AND LATCH	1
5	LBL-0293	FPU-3250 LABEL	2

Adjustable Upright Assembly [73] FPU-3250 / Rev. B

REV. 06/29/23 MH

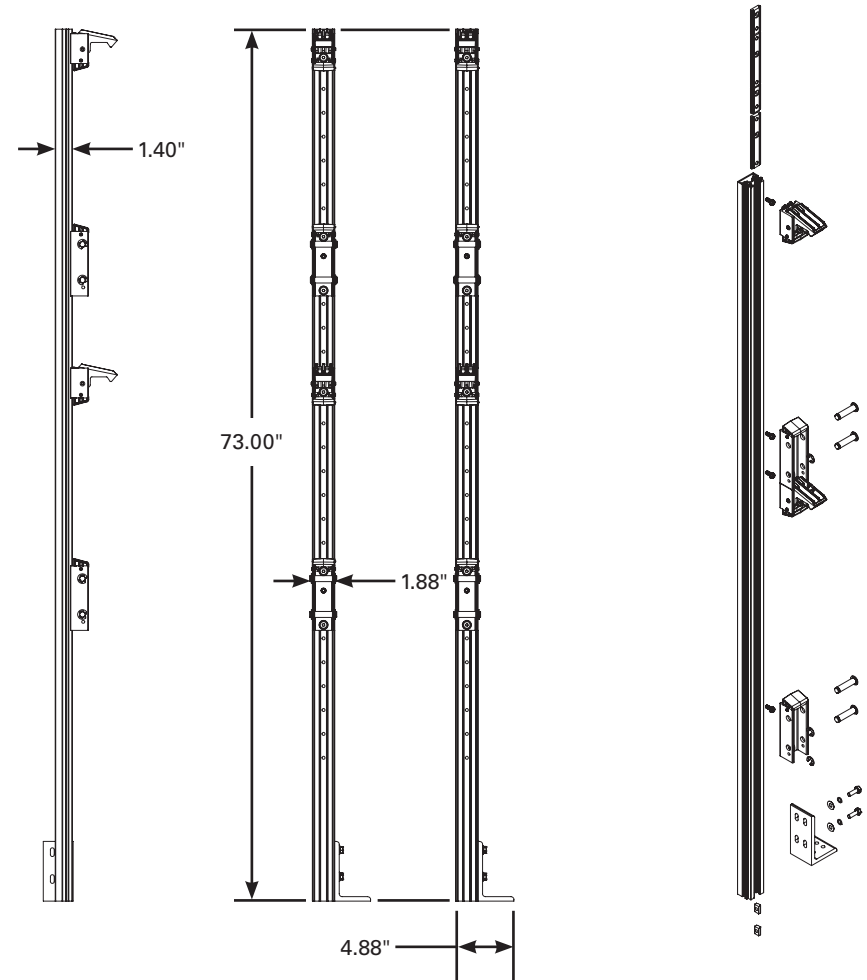
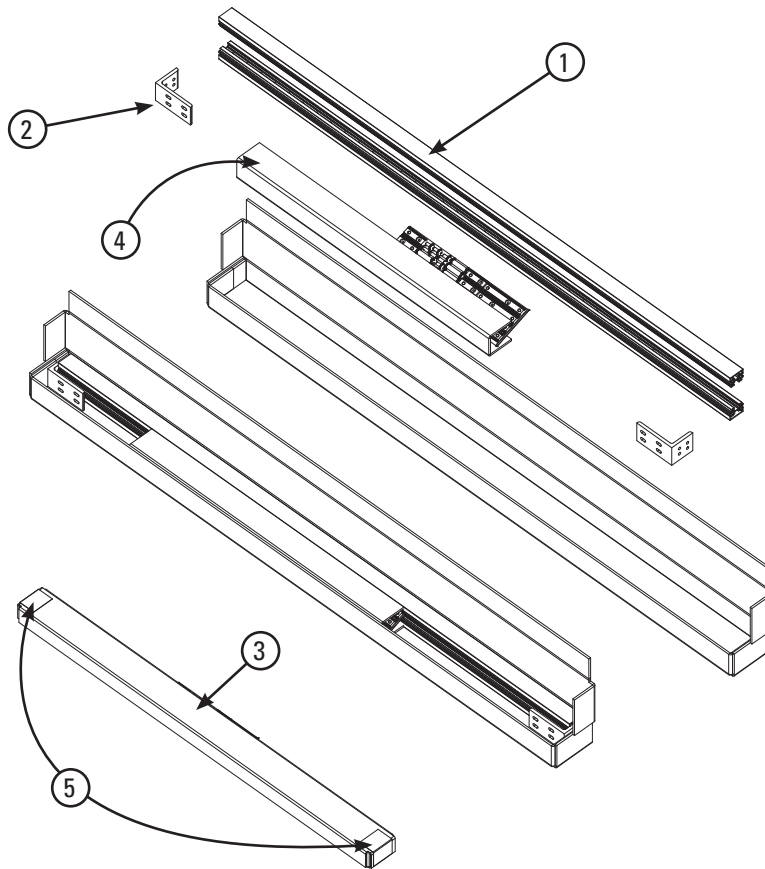

EXAMPLE AS ASSEMBLED BY CUSTOMER



INSTALLATION INSTRUCTIONS

FoldPro Shelving Uprights

SUGGESTED CUT LENGTHS FOR COMMON VEHICLES AND PIN LOCATIONS FOR PIVOTS AND LATCHES

BOTTOM OF UPRIGHT IS THE END WITH NO HOLES FOR THE FIRST SEVERAL INCHES

HKT-0272 Hardware Kit - FoldPro Upright Mounting (FRONT VIEW)

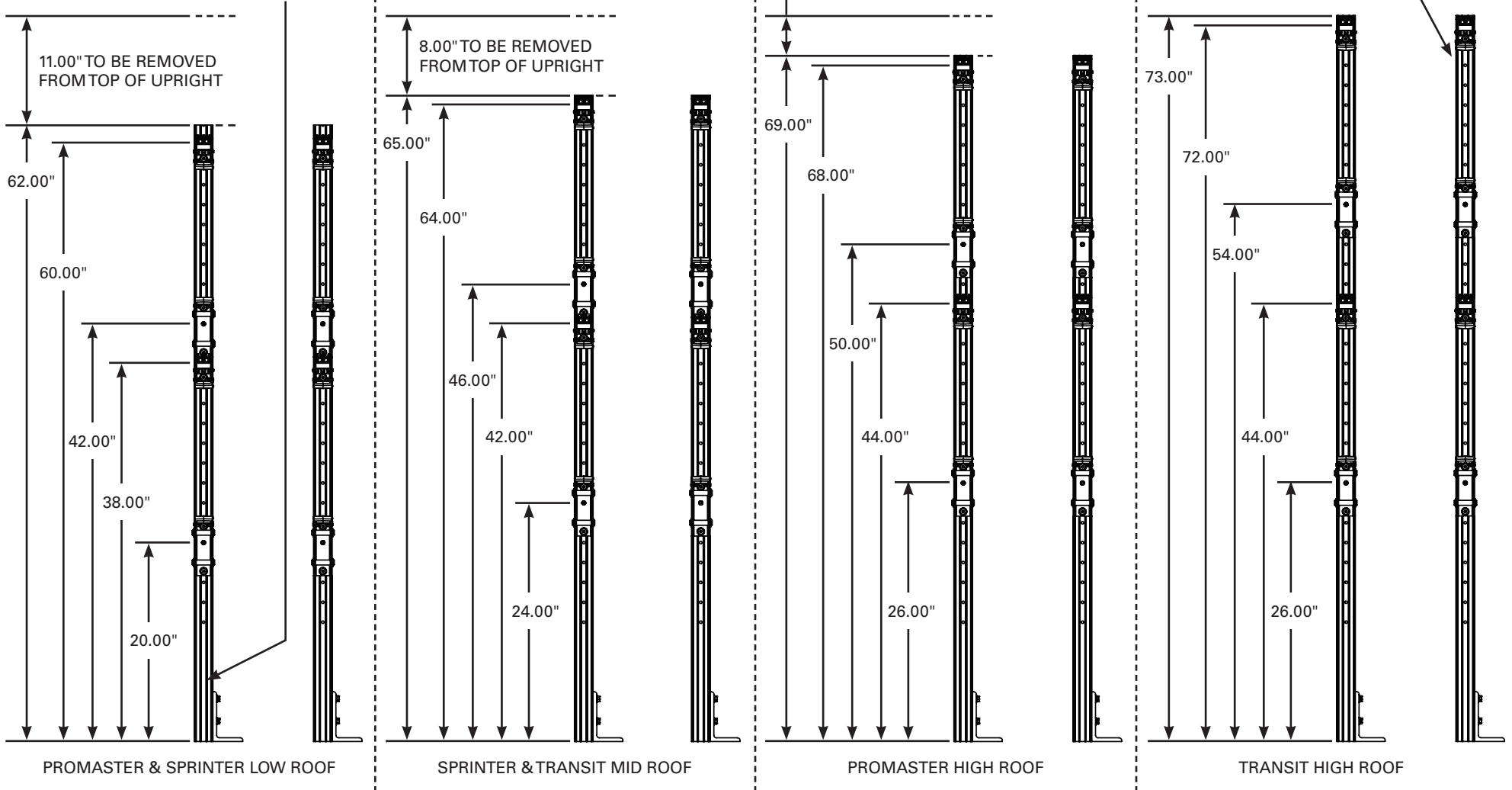



INSTALLATION INSTRUCTIONS

FoldPro Shelving Uprights

Upright Pivot & Latch Installation - Transit High Roof

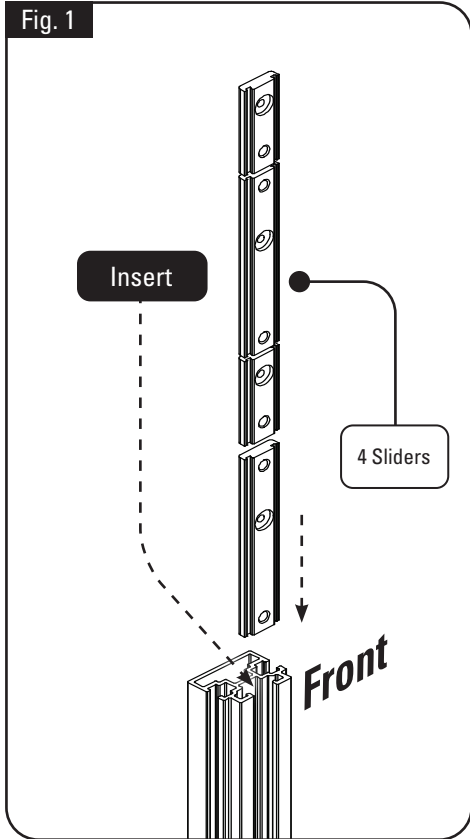

Step 1: Insert the sliders into the top of the upright supports and position them to the specified holes for a Transit High Roof Van (Fig. 1).

Note: All measurements are from the bottom up. See page 3 for proper positions for sliders.

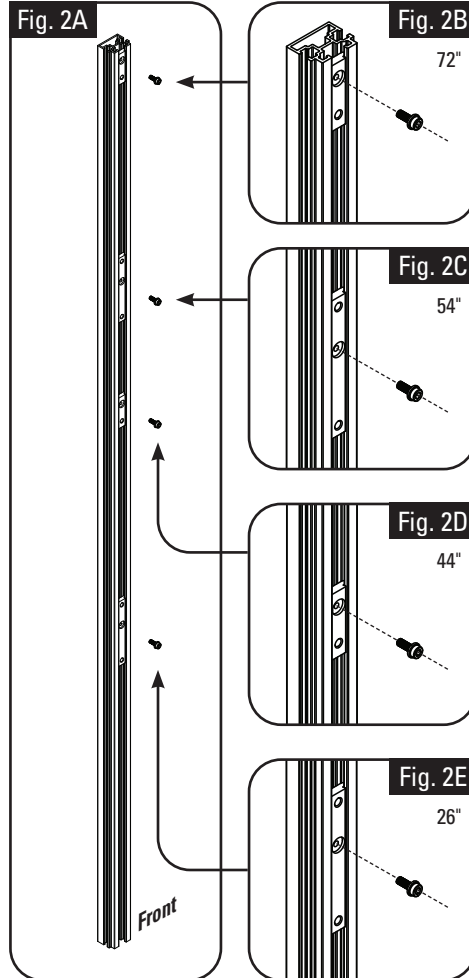

Step 2: Secure each slider in the correct position using the hex mounting bolt (Fig. 2A, B, C, D & E).

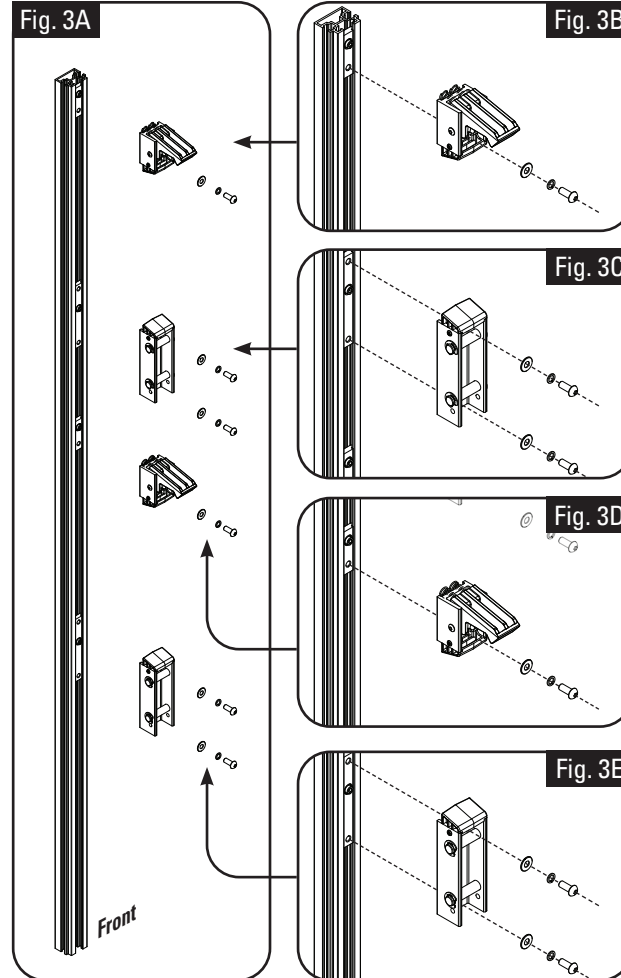

Step 3: Mount each pivot and latch to the secured sliders, using the round hex mounting bolt, lock washer and flat washer (Fig. 3A, B, C, D & E).

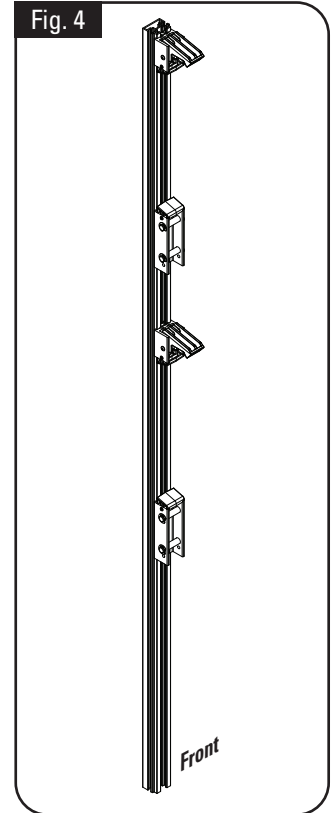

Step 4: All pivots and latches properly attached to upright (Fig. 4).

Note: For proper mounting of upright support, see page 8.



INSTALLATION INSTRUCTIONS

FoldPro Shelving Uprights

Upright Pivot & Latch Installation - ProMaster High Roof

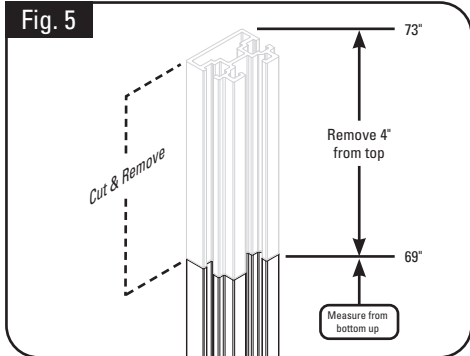

Step 1: Remove 4" from the top of the upright from 73" to 69", measuring from the bottom up (Fig. 5).

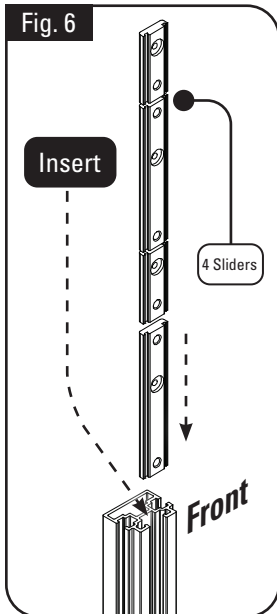

Step 2: Insert the sliders into the top of the upright supports and position them to the specified holes for a ProMaster High Roof van (Fig. 6).

Note: All measurements are from the bottom up. See page 3 for proper positions for sliders.

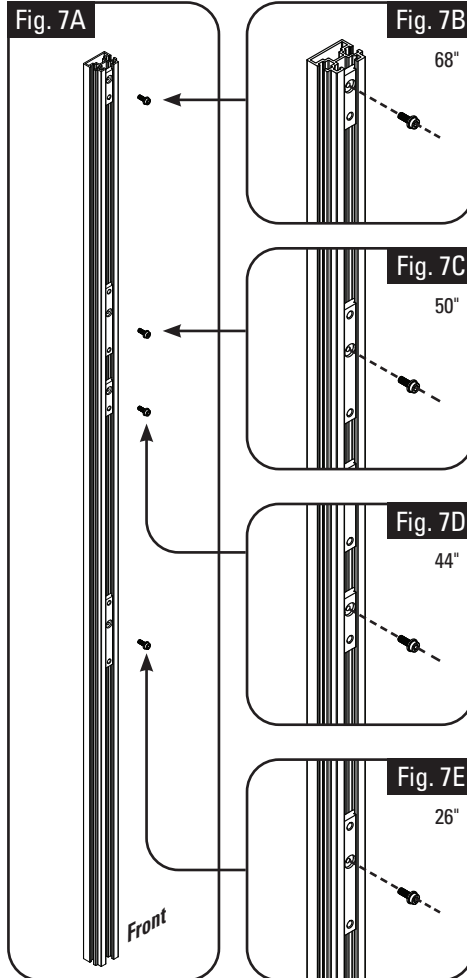

Step 3: Secure each slider in the correct position using the hex mounting bolt (Fig. 7A, B, C, D & E).

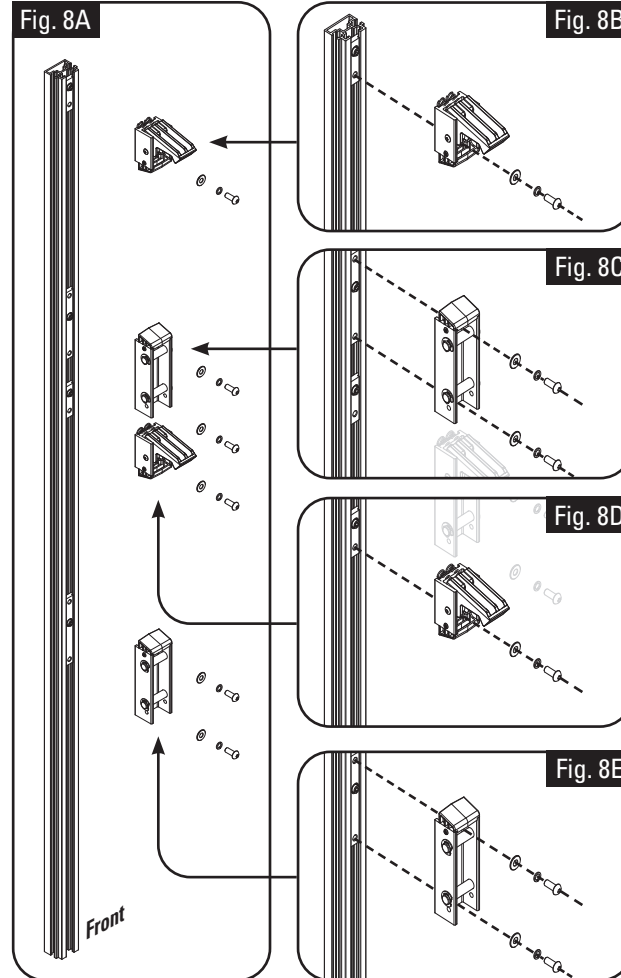

Step 4: Mount each pivot and latch to the secured sliders, using the round hex mounting bolt, lock washer and flat washer (Fig. 8A, B, C, D & E).

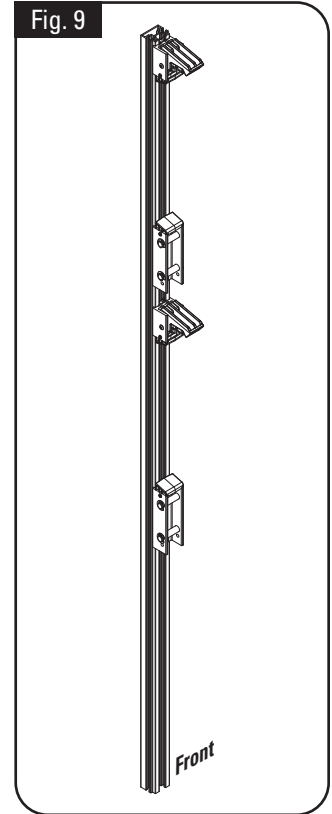

Step 5: All pivots and latches properly attached to upright (Fig. 9).

Note: For proper mounting of upright support, see page 8.



INSTALLATION INSTRUCTIONS

FoldPro Shelving Uprights

Upright Pivot & Latch Installation - Sprinter & Transit Mid Roof

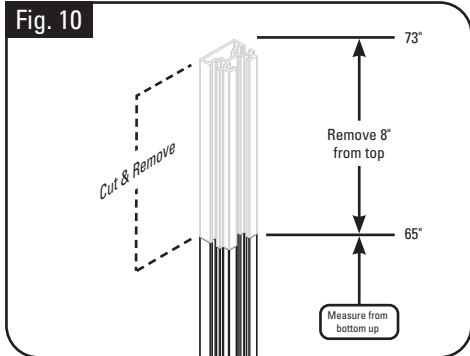

Step 1: Remove 4" from the top of the upright from 73" to 69", measuring from the bottom up (Fig. 10).

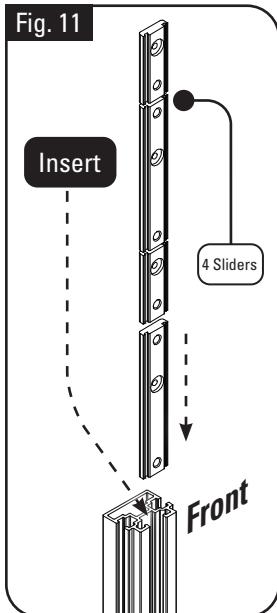

Step 2: Insert the sliders into the top of the upright supports and position them to the specified holes for a Promaster High Roof van (Fig. 11).

Note: All measurements are from the bottom up. See page 3 for proper positions for sliders.

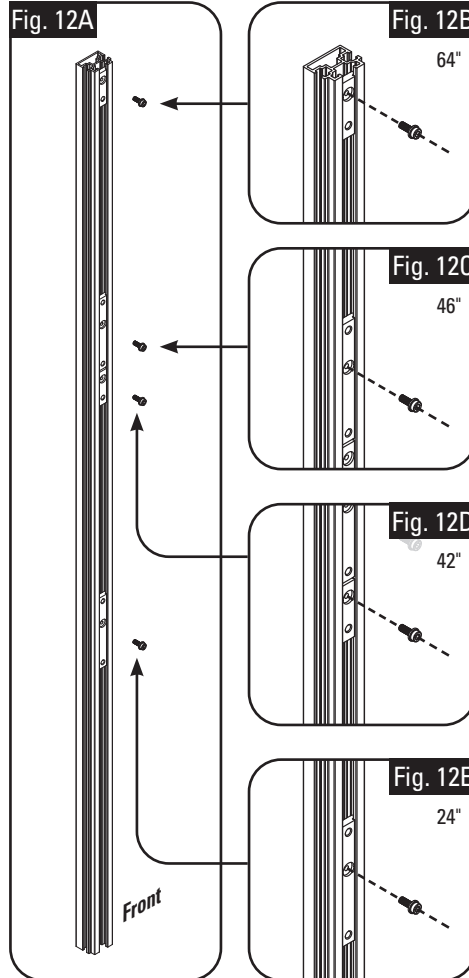

Step 3: Secure each slider in the correct position using the hex mounting bolt (Fig. 12A, B, C, D & E).

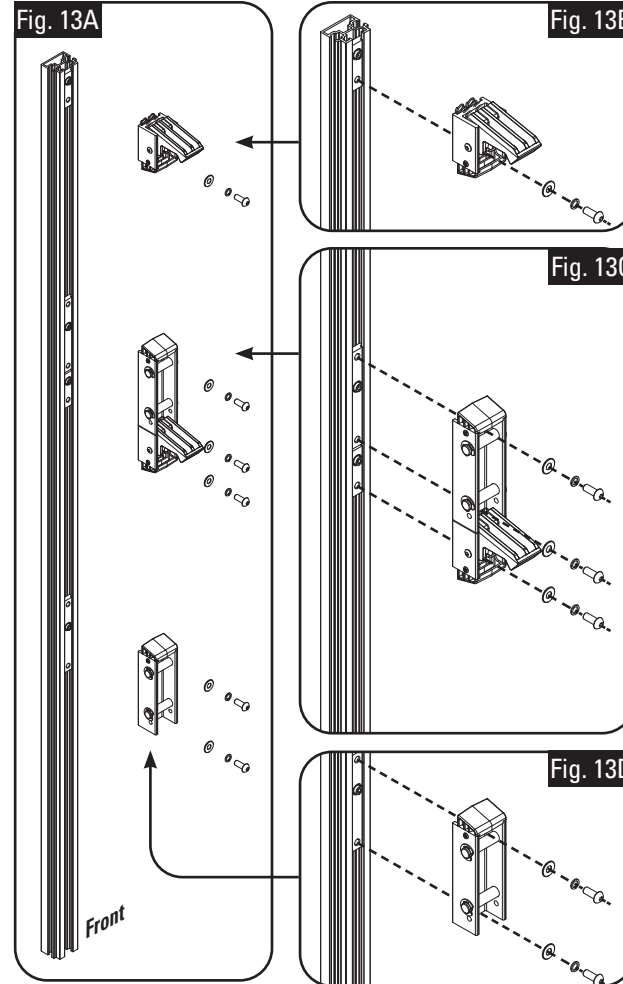

Step 4: Mount each pivot and latch to the secured sliders, using the round hex mounting bolt, lock washer and flat washer (Fig. 13A, B, C & D).

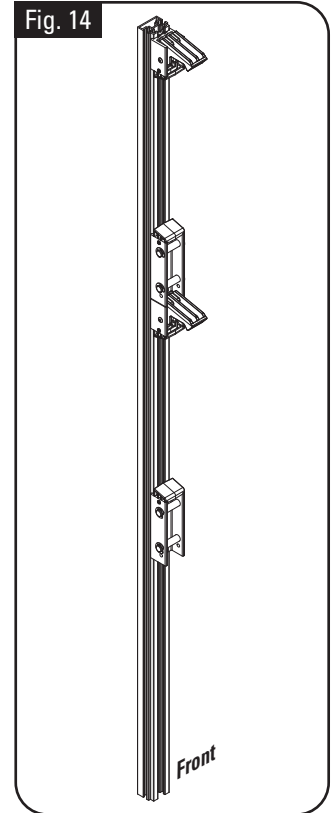

Step 5: All pivots and latches properly attached to upright (Fig. 14).

Note: For proper mounting of upright support, see page 8.



INSTALLATION INSTRUCTIONS

FoldPro Shelving Uprights

Upright Pivot & Latch Installation - ProMaster & Sprinter Low Roof

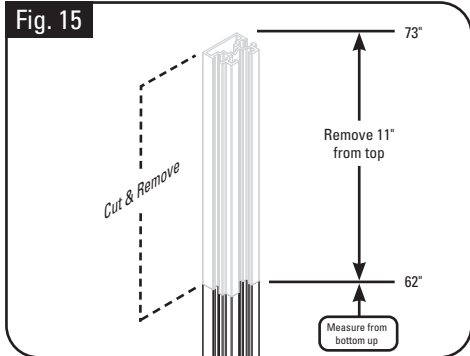

Step 1: Remove 4" from the top of the upright from 73" to 69", measuring from the bottom up (Fig. 15).

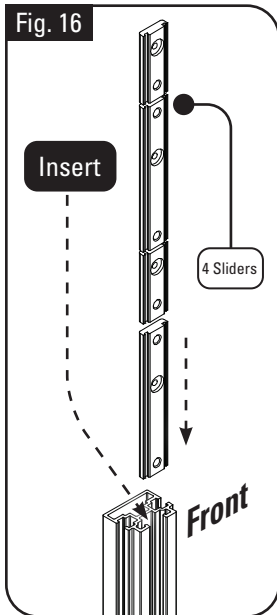

Step 2: Insert the sliders into the top of the upright supports and position them to the specified holes for a ProMaster High Roof van (Fig. 16).

Note: All measurements are from the bottom up. See page 3 for proper positions for sliders.

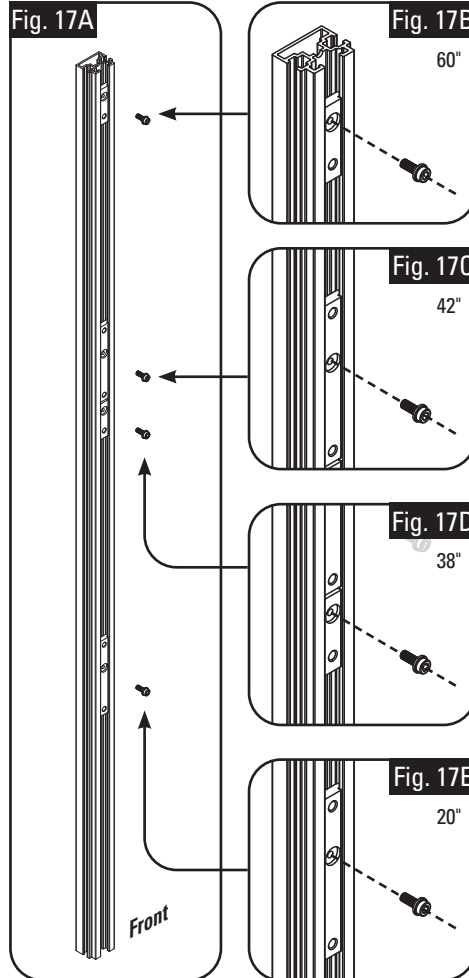

Step 3: Secure each slider in the correct position using the hex mounting bolt (Fig. 17A, B, C, D & E).

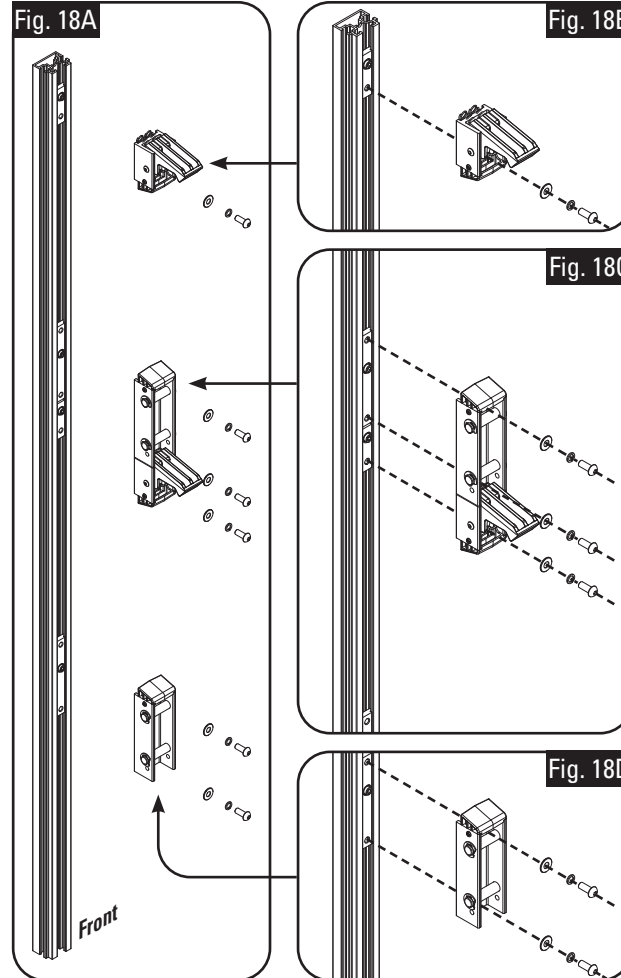

Step 4: Mount each pivot and latch to the secured sliders, using the round hex mounting bolt, lock washer and flat washer (Fig. 18A, B, C, & D).

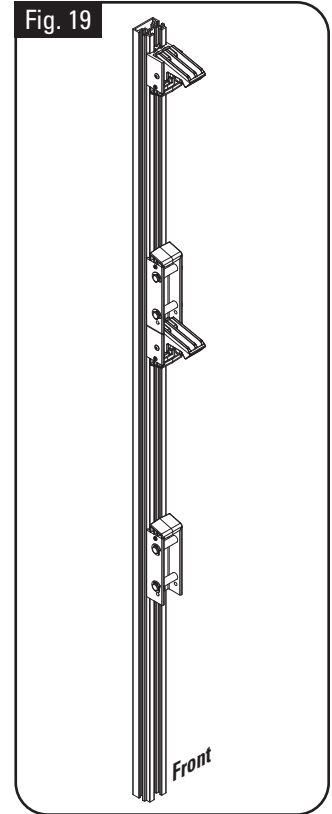

Step 5: All pivots and latches properly attached to upright (Fig. 19).

Note: For proper mounting of upright support, see page 8.



INSTALLATION INSTRUCTIONS

FoldPro Shelving Uprights

Upright Support Mounting Bracket Installation - All Models

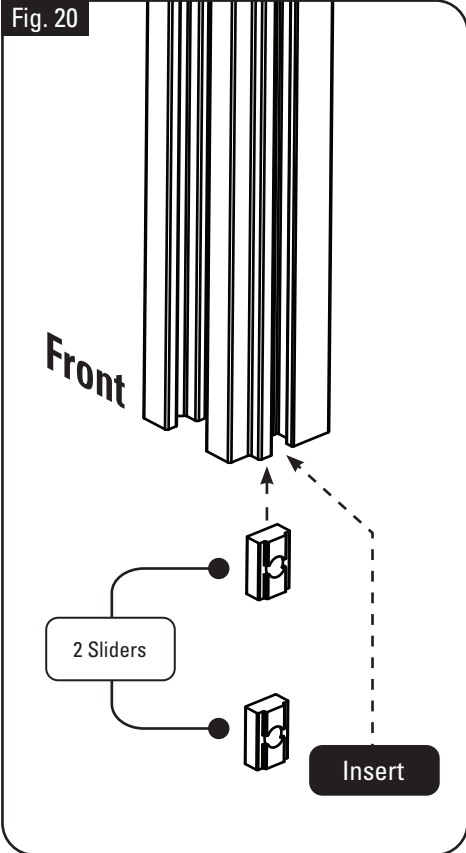

Step 1: Insert the shelving support sliders into the slot at the bottom of the upright.

Adjust the sliders to match the hole position on the support bottom mounting bracket (Fig. 20).

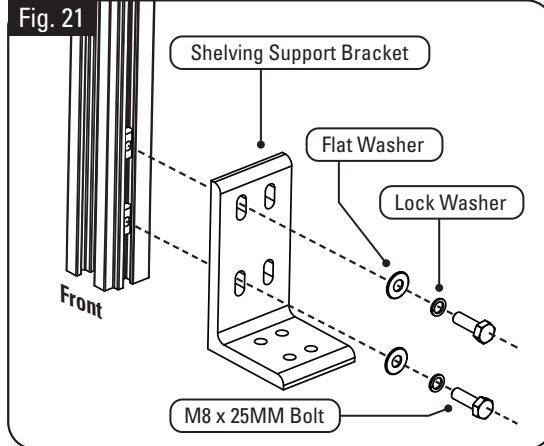

Step 2: Attached the FoldPro shelving support to the sliders, on the bottom right side of the upright (Fig. 21).

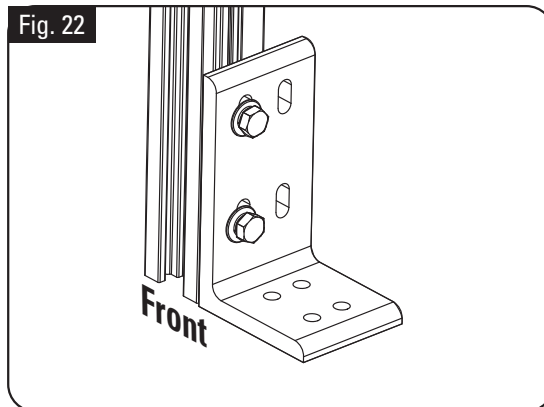

Step 3: Support bottom mounting bracket secured to upright in the normal position (Fig. 22).

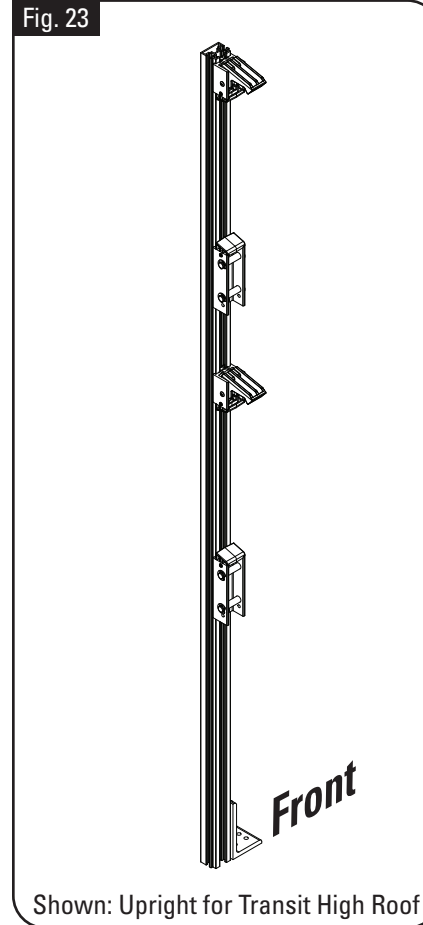

Shown: Upright for Transit High Roof

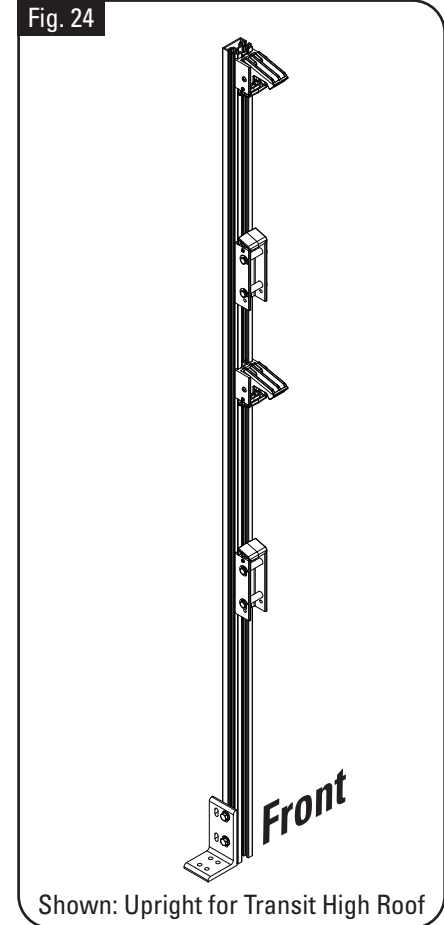

Shown: Upright for Transit High Roof

Step 4: The FoldPro shelving support bottom mounting bracket can be mounted in the normal position (Fig. 23) or in the alternate position on the left side of the upright (Fig. 24) as needed.