

2 Person Lift Recommended



Doc#: USAM-FPM1020-US01 REV A 1123

Revised: 02/05/24 WLH

PRIME DESIGN, A SAFE FLEET BRAND • WEBSITE: WWW.PRIMEDESIGN.NET • TM & © 2024 PRIME DESIGN. PROTECTED BY ONE OR MORE OF THE FOLLOWING PATENT NO.'S 6764268, 6971563, 8511525, 8991889, 9102482, 9415726, 9481314, 9506292, 9776476, 9796340, 10470565, 10486608, 10501022, 10578182, 10654420, 10688937, 10836312 AND OTHER PATENTS PENDING



## Table of Contents

FPM-1021 / RAM ProMaster Standard & High Roof

### General Information

Assembly Requirements.....	1
FoldPro Shelving Mounting System ProMaster FPM-1021 / Rev. B .....	2
HKT-0272 Hardware Kit - FoldPro Mounting ProMaster .....	3

### System Installation

Hardware & Upright Installation Procedures.....	4
FoldPro Shelving Layouts for ProMaster.....	5
FoldPro Shelving Layout: Low Roof, 118" Wheel Base (PM11) - DRIVER SIDE ONLY....	6
FoldPro Shelving Layout: Low Roof, 136" Wheel Base (PM21) - DRIVER SIDE.....	7
FoldPro Shelving Layout: Low Roof, 136" Wheel Base (PM21) - PASS. SIDE .....	8
FoldPro Shelving Layout: Low Roof, 136" Wheel Base (PM21) - DRIVER SIDE....	9
FoldPro Shelving Layout: Low Roof, 136" Wheel Base (PM21) - PASS. SIDE .....	10
FoldPro Shelving Layout: High Roof, 159" Wheel Base (PM42) - DRIVER SIDE... ..	11
FoldPro Shelving Layout: Low Roof, 136" Wheel Base (PM21) - PASS. SIDE .....	12
FoldPro Shelving Layout: High Roof, 159" Ext. Wheel Base (PM52) - DRIVER SIDE ..	13
FoldPro Shelving Layout: High Roof, 159" Ext. Wheel Base (PM52) - PASS. SIDE ..	14



### Assembly Requirements



**INSTALLER NOTE:** It is important to correctly follow these assembly instructions. These instructions for assembly are provided by the manufacturer at time of FoldPro Shelving delivery, and reflect the technical specifications applicable at the time of writing.

- These instructions are subject to change if the manufacturer revises the parts and/or production of the subsystems and accessories used in the brand's vehicles. Following the instructions for assembly will ensure proper installation of the product. The manufacturer will not be held liable if these instructions are not followed.
- The addition of parts and/or components not original to this FoldPro Shelving are discouraged. Use only OEM supplied parts.
- Consultation of the OEM vehicle may be required during assembly to avoid vehicle damage. Ensure bolt locations will not damage any critical parts of the vehicle—i.e. gas tank, wiring harnesses, or hoses—before drilling.

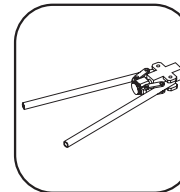

Plus Nut Applicator Tool

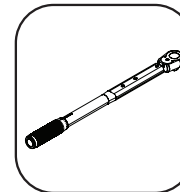

Torque Wrench w/ 13MM Socket

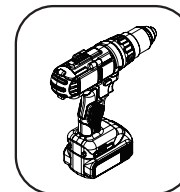

Power Drill w/ 1/2" Drill Bit



## INSTALLATION INSTRUCTIONS

FoldPro Shelving

ITEM	PART #	DESCRIPTION	QTY
1	CHL-1056	FOLDPRO SHELVING MOUNTING CHANNEL, PROMASTER	3
2	HKT-0272	HARDWARE KIT, PROMASTER FP MOUNTING, STREET SIDE	1
3	BOX-1087	BOX, L(36.50") X W(3.25") X D(3.25")	1
4	AV-1218	FOLDPRO SHELVING ANGLE MOUNTING BRACKET	4
5	LBL-0291	FPM-1021 LABEL	2

## FoldPro Shelving Mounting System ProMaster FPM-1021 / Rev. B

REV. 02/05/24 WLH

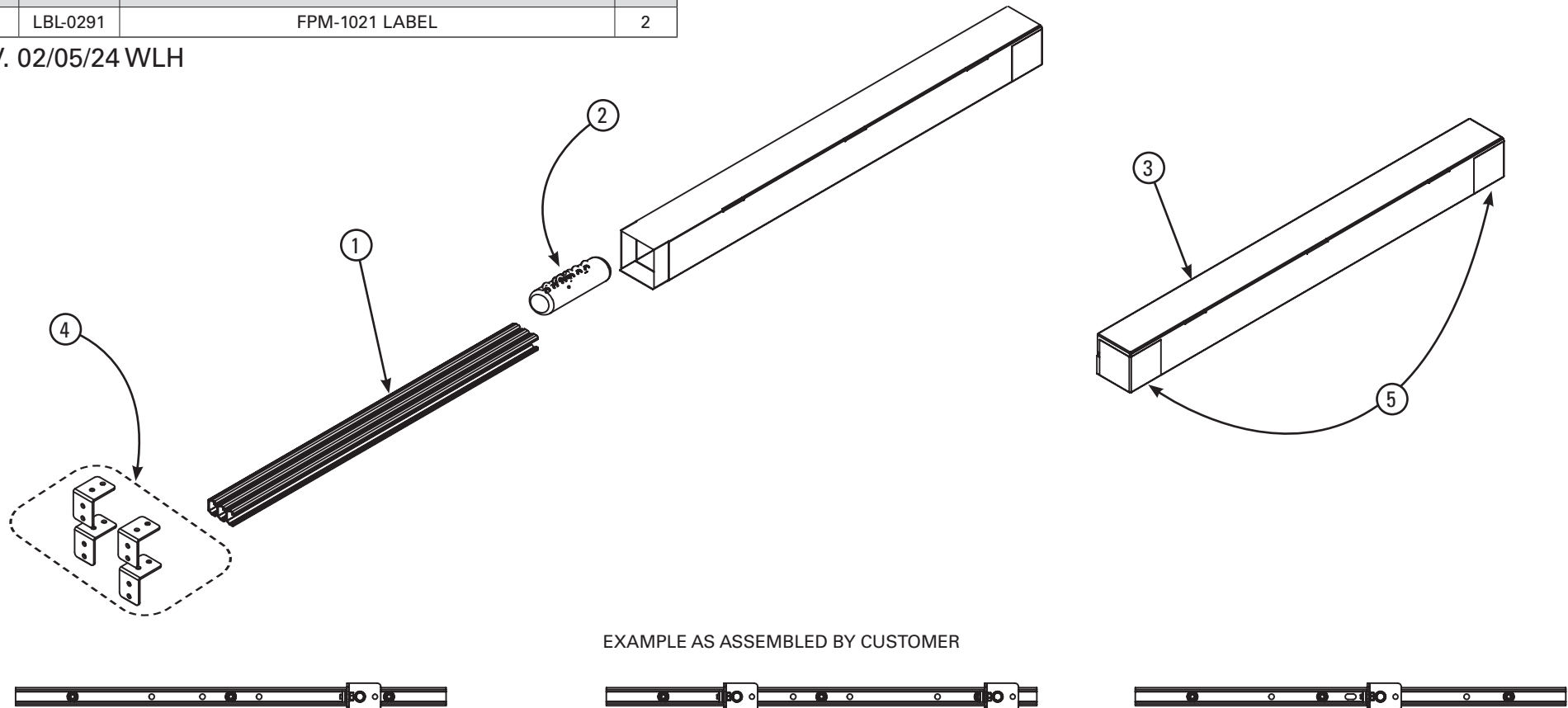



## INSTALLATION INSTRUCTIONS

FoldPro Shelving

### HKT-0272 Hardware Kit - FoldPro Mounting ProMaster

ITEM	PART #	DESCRIPTION	QTY
1	NBR-1011	NUT BRACKET, M8	4
2	WSH-1001-G	5/16" FLAT WASHER	17
3	BLA-030-M8	M8 X 30MM ALLEN CAP SCREW, SST	9
4	NRV-1025-M8	NUT RIVET M8 X 1.25MM	9
5	WSH-1002-G	5/16" LOCK WASHER	17
6	BLT-1018-M8	M8 X 18MM HEX HEAD BOLT	8
7	NBR-1014	ALURACK CROSSBAR NUT BRACKET	4
8	BAG-3512	BAG, POLY 4 MIL 6" X 12"	1

REV. 05/16/23 MH

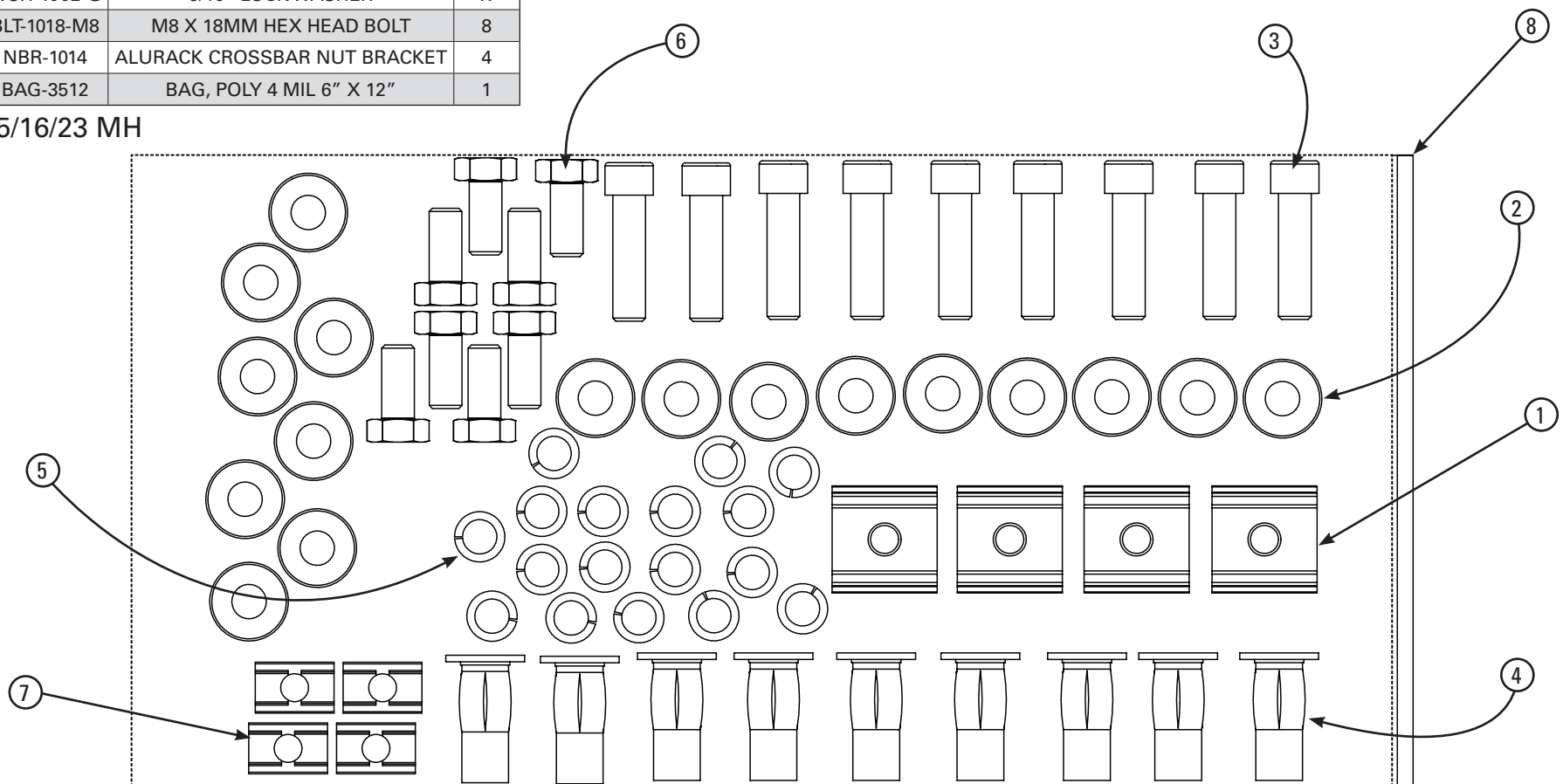



## INSTALLATION INSTRUCTIONS

FoldPro Shelving

### Hardware & Upright Installation Procedures

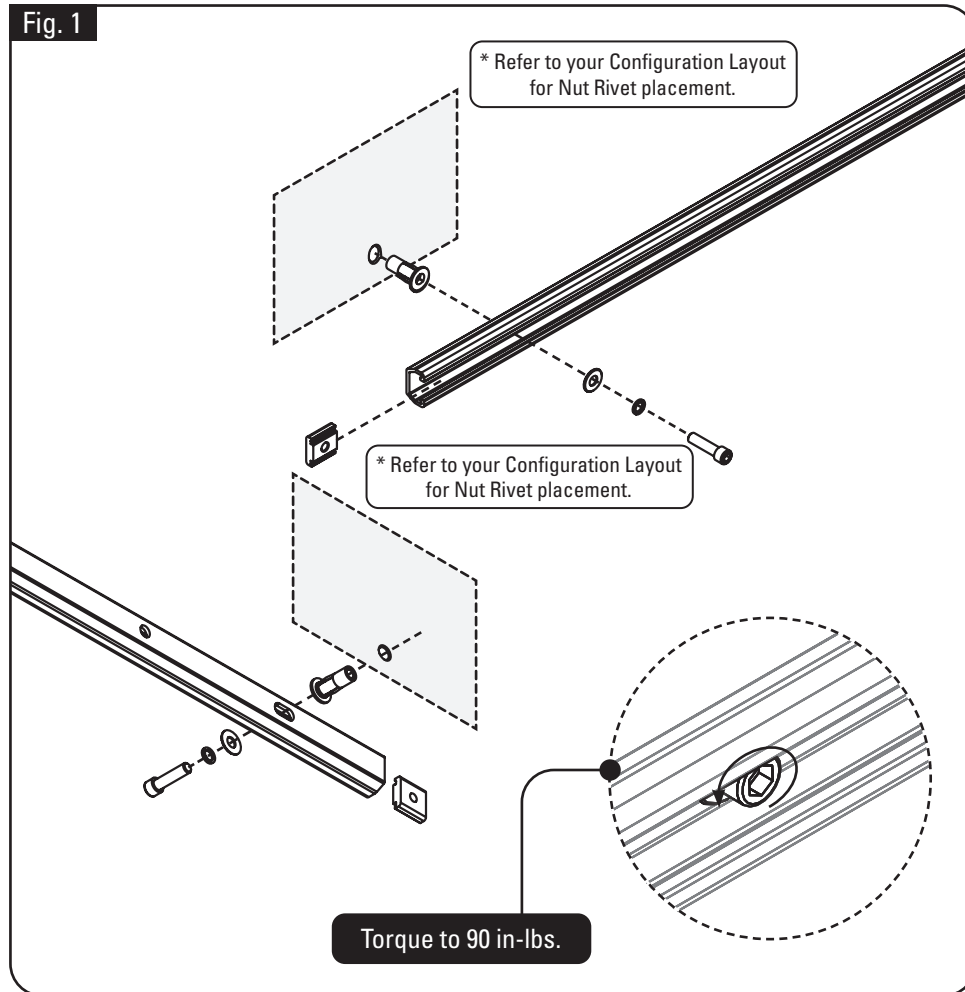

**NOTE:** Mounting Assembly Layouts and Placements vary according to your Vehicle Model. Refer to views on pages 4–12 to determine your Model configuration, and install according to your OEM (Fig. 1).

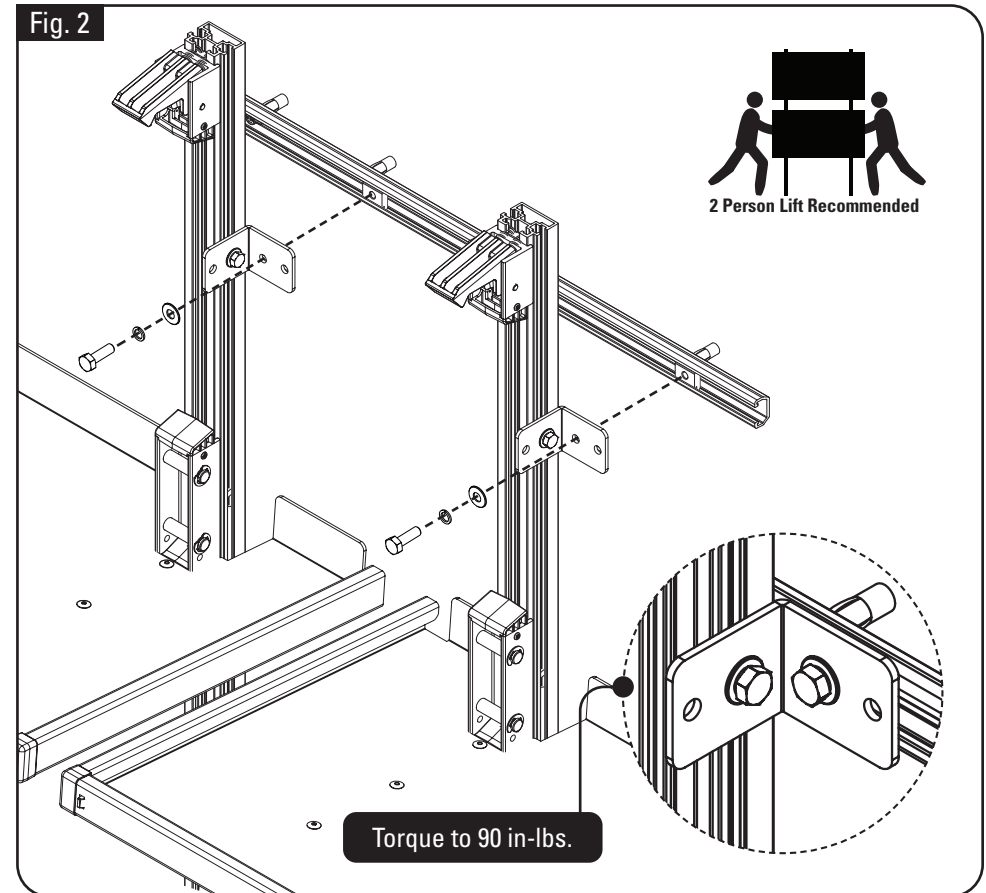

**Step 1:** Install FoldPro Shelving Uprights using provided Upright Hardware (sold separately) into Mounting Channel Nut Brackets as shown (Fig. 2).

**NOTE:** Shelving is removed from the views below for illustrative purposes only.



## FoldPro Shelving Layouts for ProMaster

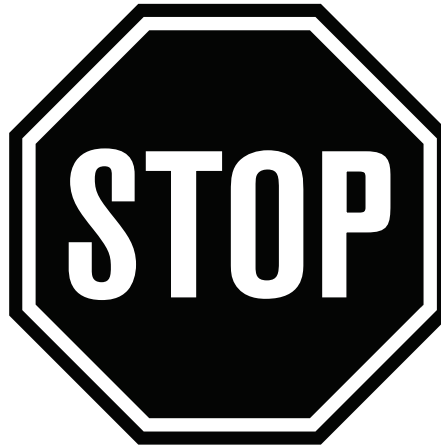

**NOTE:** Drilling into the vehicle wall and cutting a Mounting Channel may be required for proper fitting, according to varying wall layout and door placements. Refer to views on pages 6-14 to determine your Model configuration, and install according to your OEM.



**WARNING:** Before drilling, ensure the bolt location will not damage any critical parts of the vehicle.



## FoldPro Shelving Layout: Low Roof, 118" Wheel Base (PM11) - DRIVER SIDE ONLY

Fig. 3A

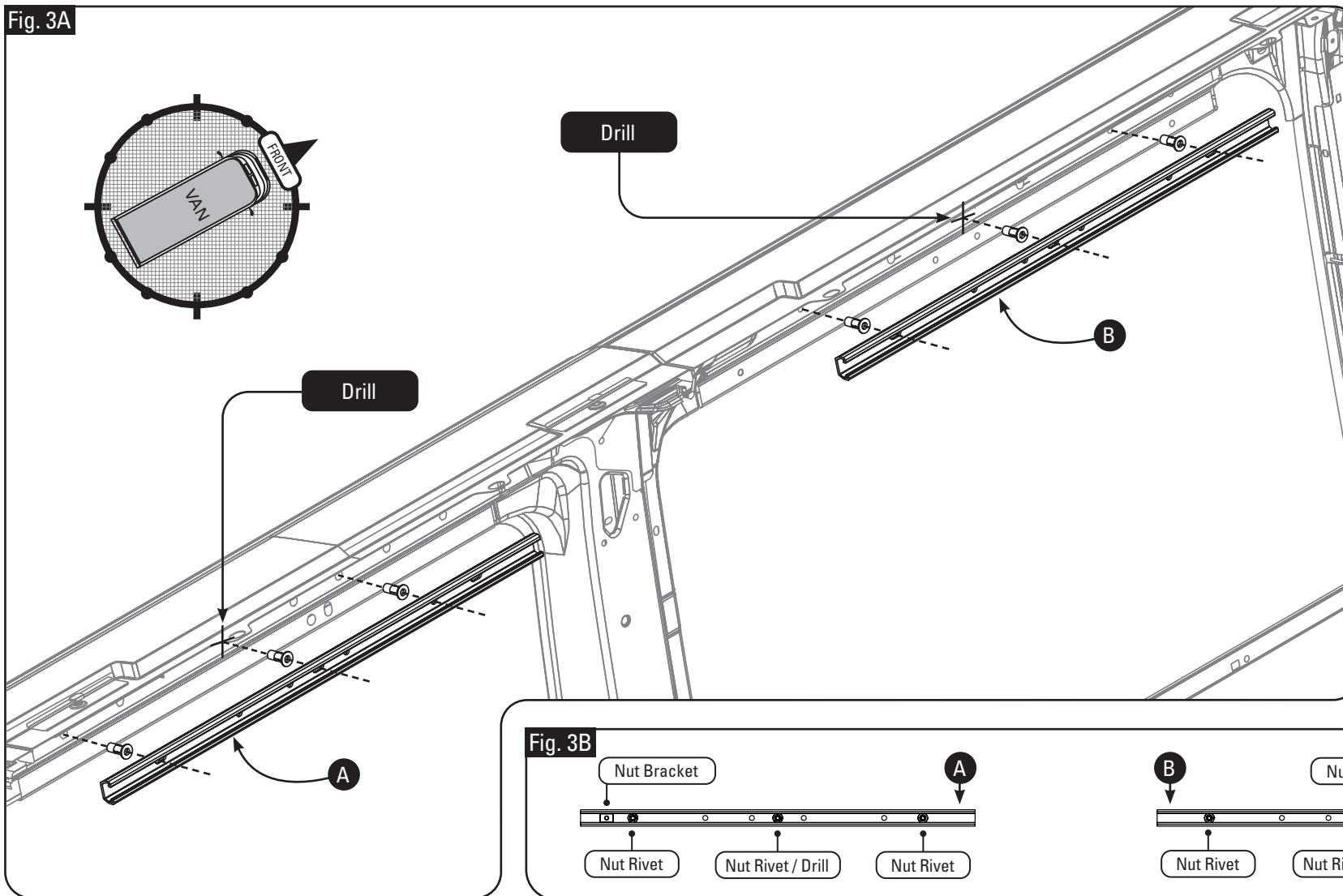

**Step 1:** Drill into indicated locations and install Nut Rivets as shown (Fig. 3A & B).

**Step 2:** Install Hardware and Uprights in the sequence shown according to the Hardware and Upright Installation Procedures on Page 4.

Fig. 3B







## FoldPro Shelving Layout: Low Roof, 136" Wheel Base (PM21) - DRIVER SIDE

Fig. 4A

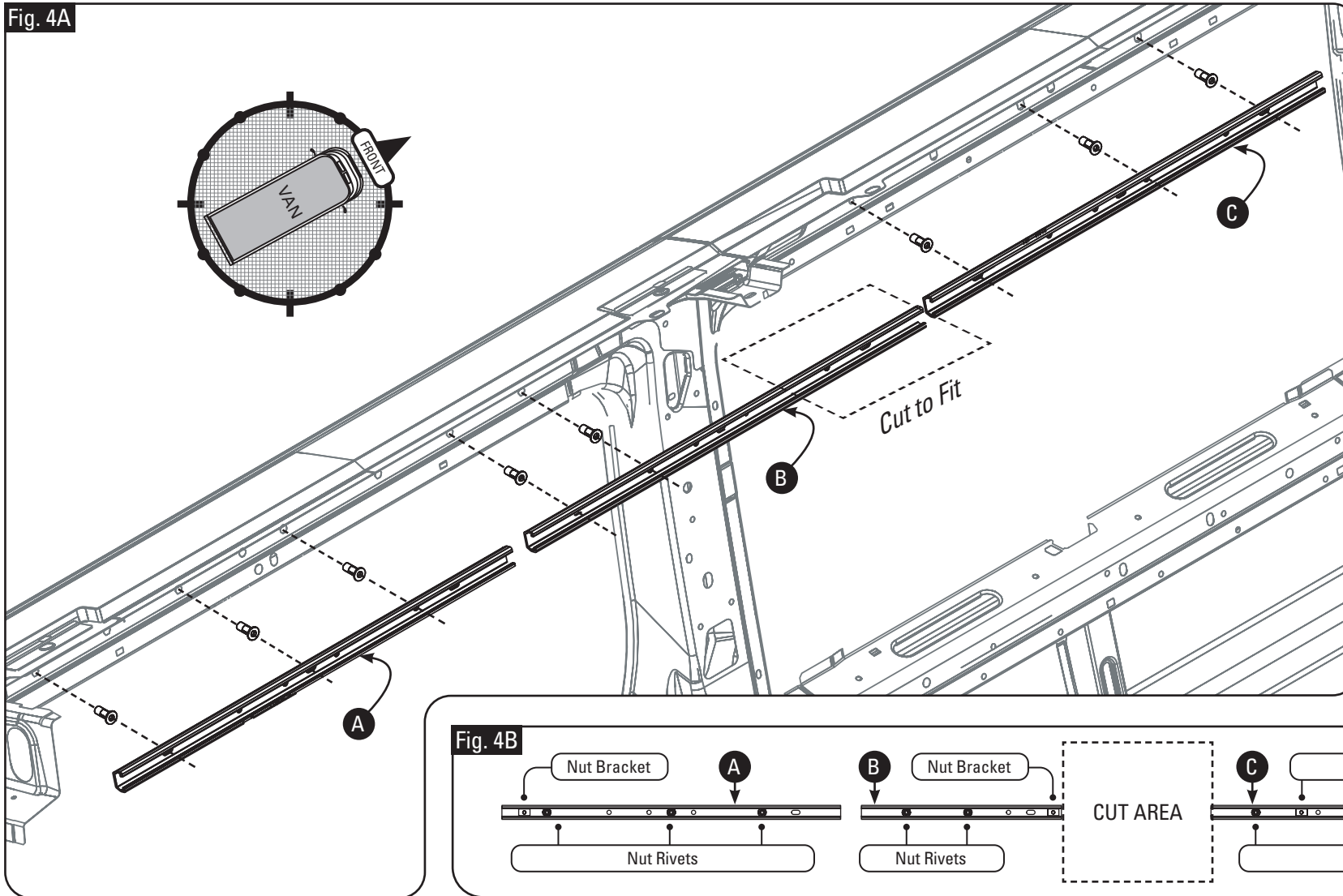

**Step 1:** Cut center channel as shown (approximately 15.50") to fit your wall layout. Drill into indicated locations and install Nut Rivets as shown (Fig. 4A & B).

**Step 2:** Install Hardware and Uprights in the sequence shown according to the Hardware and Upright Installation Procedures on Page 4.

Fig. 4B

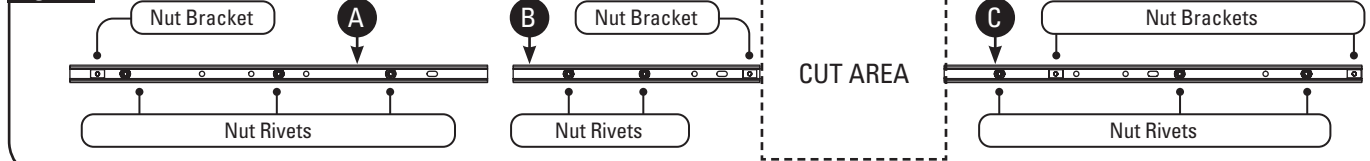



### FoldPro Shelving Layout: Low Roof, 136" Wheel Base (PM21) - PASSENGER SIDE

Fig. 5A

Fig. 5B

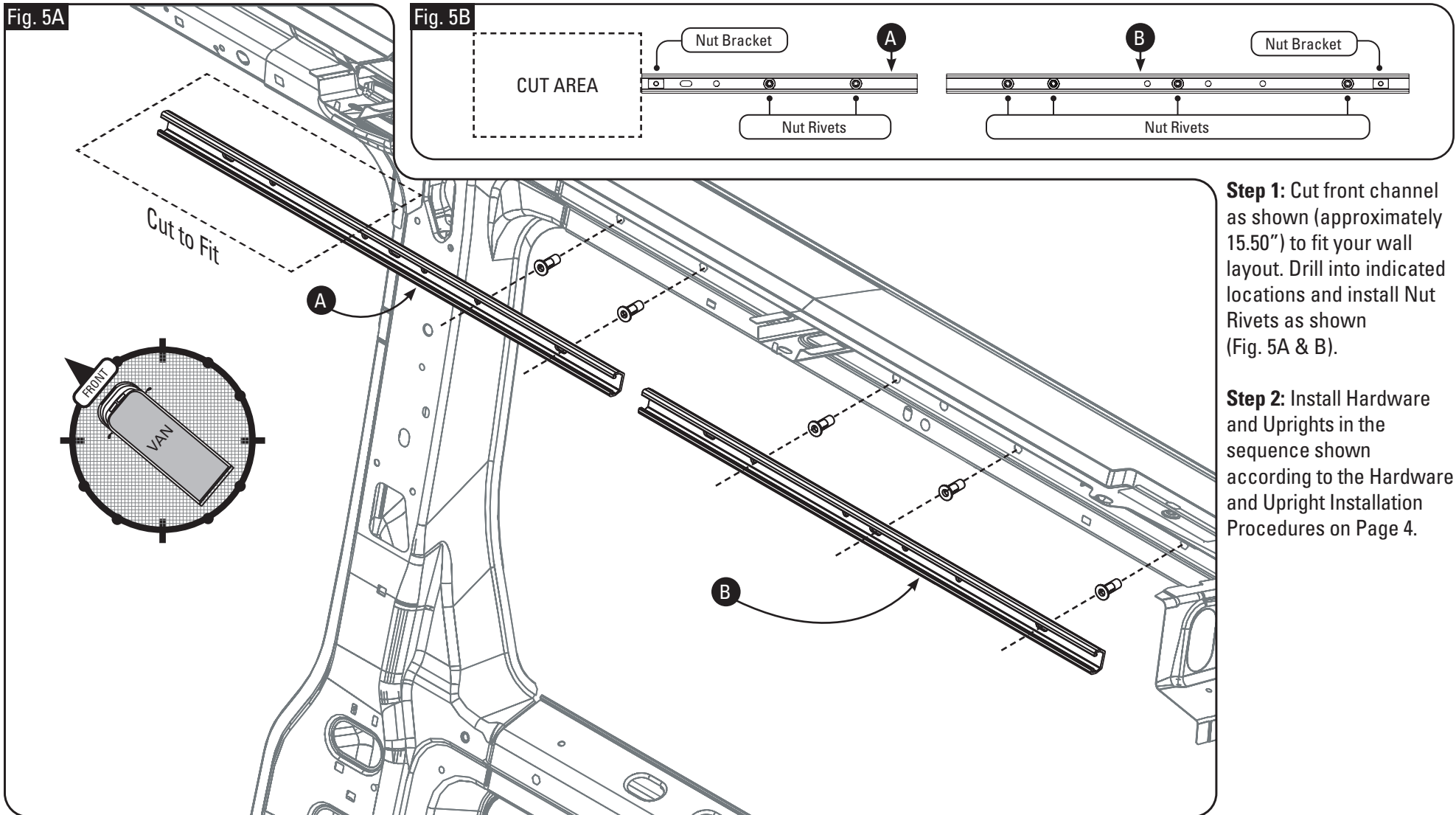

**Step 1:** Cut front channel as shown (approximately 15.50") to fit your wall layout. Drill into indicated locations and install Nut Rivets as shown (Fig. 5A & B).

**Step 2:** Install Hardware and Uprights in the sequence shown according to the Hardware and Upright Installation Procedures on Page 4.



## FoldPro Shelving Layout: Low Roof, 136" Wheel Base (PM21) - DRIVER SIDE

Fig. 6A

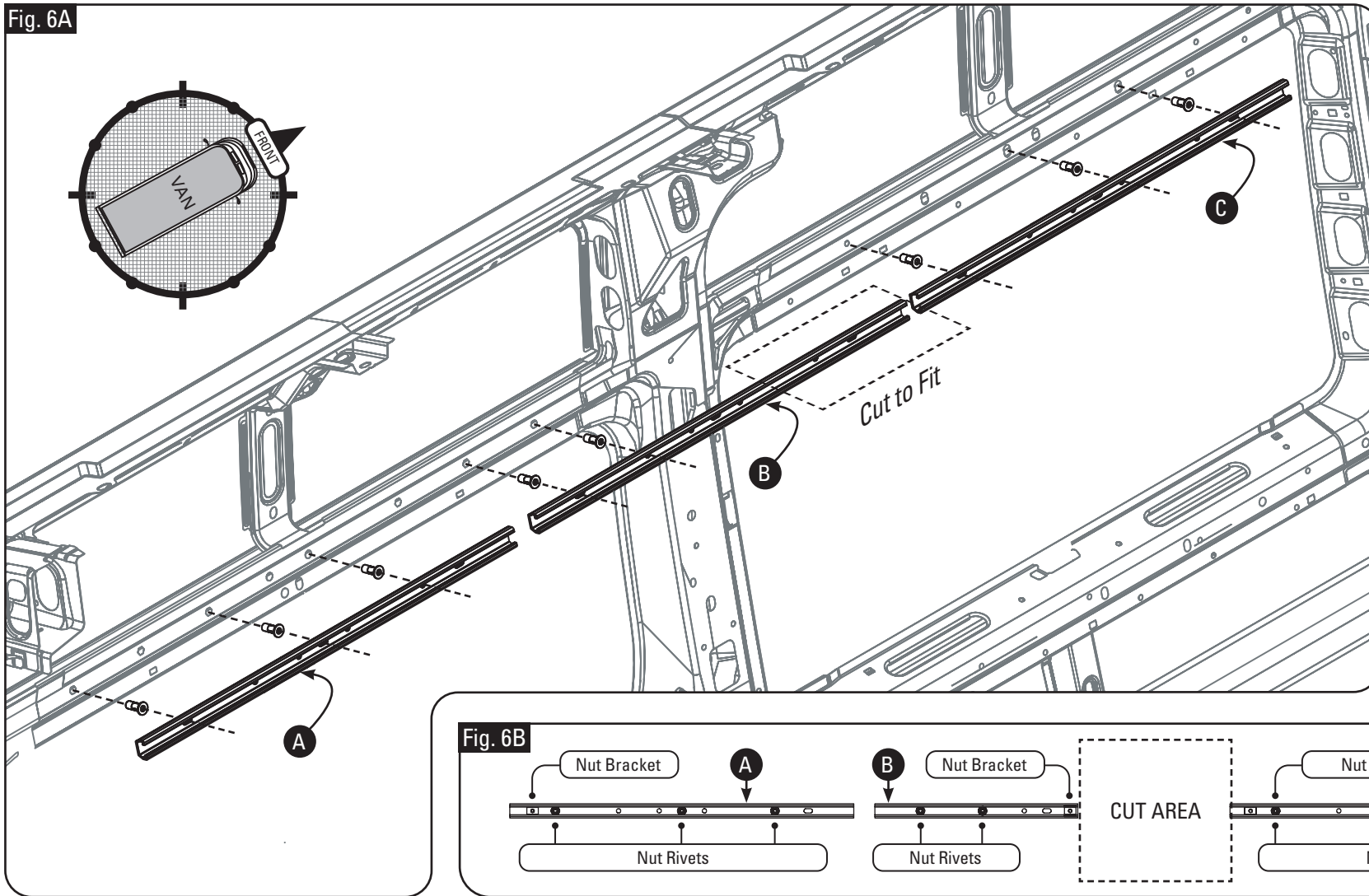

**Step 1:** Cut center channel as shown (approximately 15.50") to fit your wall layout. Drill into indicated locations and install Nut Rivets as shown. (Fig. 6A & B).

**Step 2:** Install Hardware and Uprights in the sequence shown according to the Hardware and Upright Installation Procedures on Page 4.



### FoldPro Shelving Layout: Low Roof, 136" Wheel Base (PM21) - PASSENGER SIDE

Fig. 7A

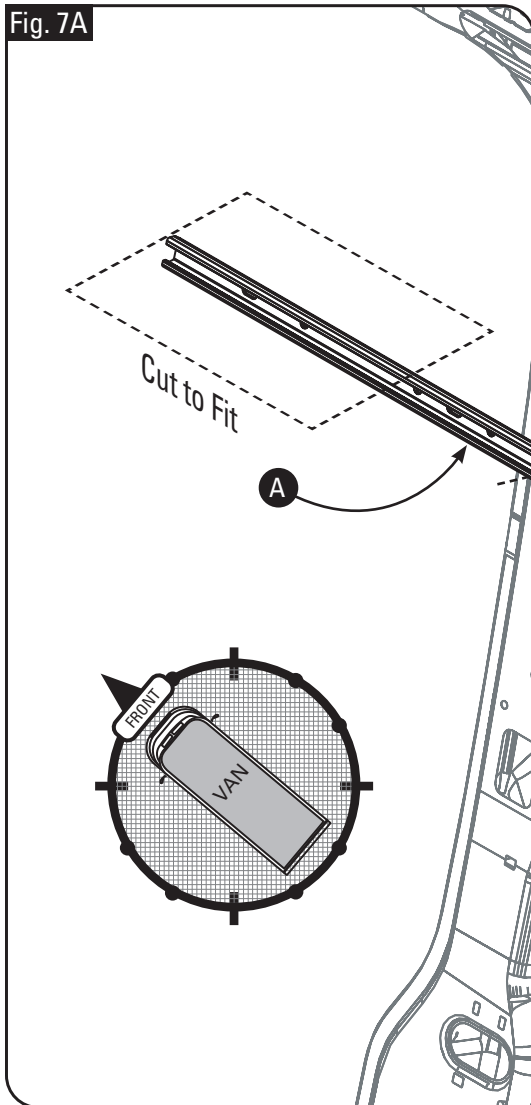
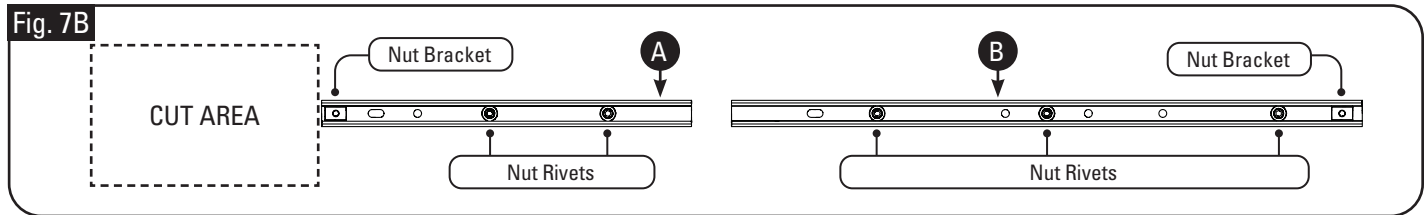

Fig. 7B



**Step 1:** Cut front channel as shown (approximately 15.50") to fit your wall layout. Drill into indicated locations and install Nut Rivets as shown (Fig. 7A & B).

**Step 2:** Install Hardware and Uprights in the sequence shown according to the Hardware and Upright Installation Procedures on Page 4.



### FoldPro Shelving Layout: High Roof, 159" Wheel Base (PM42) - DRIVER SIDE

Fig. 8A

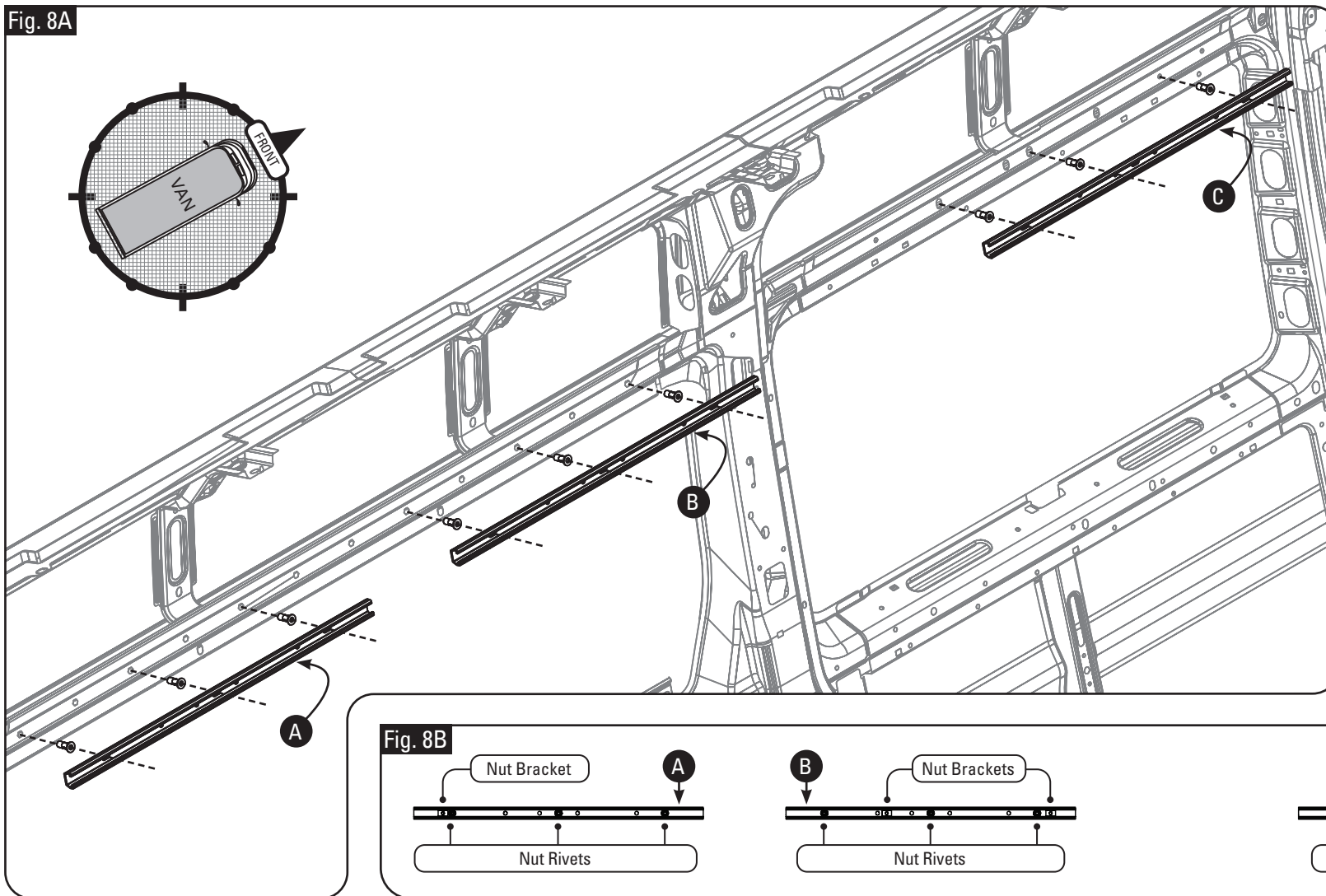

**Step 1:** Install Nut Rivets as shown. (Fig. 8A & B).

**Step 2:** Install Hardware and Uprights in the sequence shown according to the Hardware and Upright Installation Procedures on Page 4.



### FoldPro Shelving Layout: Low Roof, 136" Wheel Base (PM21) - PASSENGER SIDE

Fig. 9A

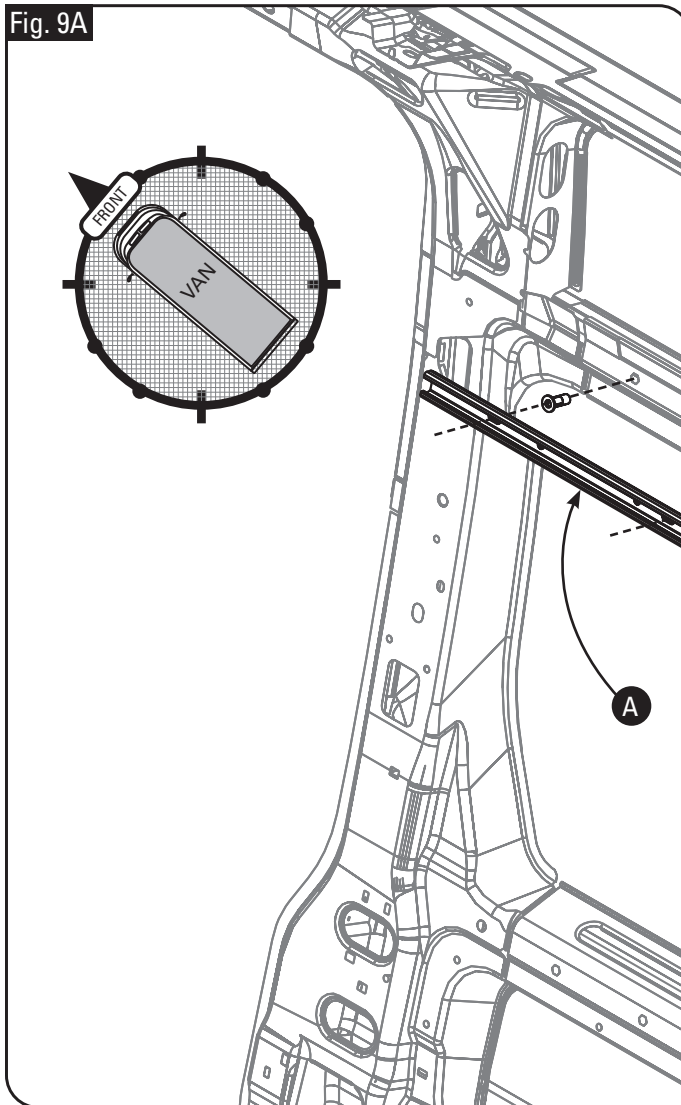
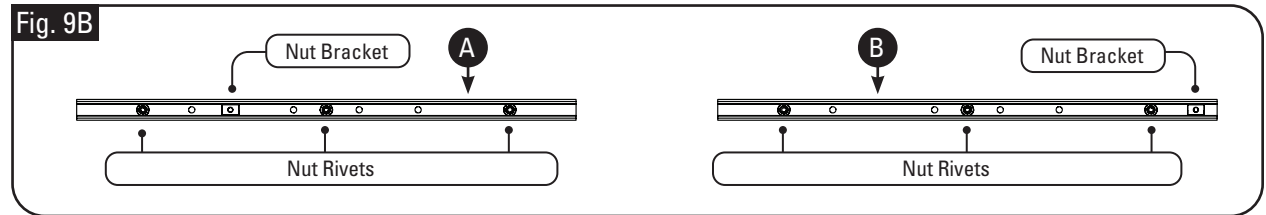

Fig. 9B



**Step 1:** Install Nut Rivets as shown (Fig. 9A & B).

**Step 2:** Install Hardware and Uprights in the sequence shown according to the Hardware and Upright Installation Procedures on Page 4.



### FoldPro Shelving Layout: High Roof, 159" Ext. Wheel Base (PM52) - DRIVER SIDE

Fig. 10A

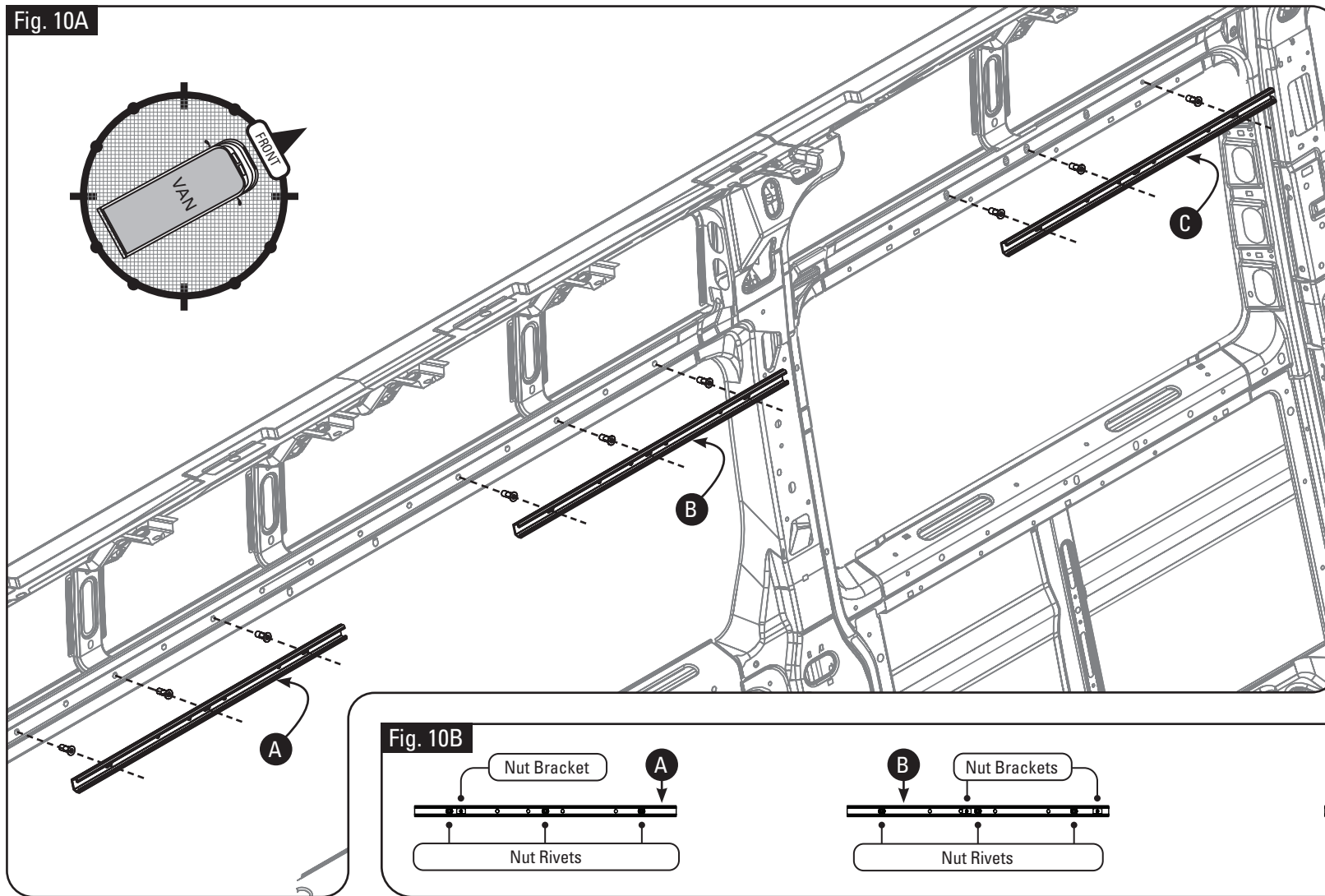

**Step 1:** Install Nut Rivets as shown. (Fig. 10A & B).

**Step 2:** Install Hardware and Uprights in the sequence shown according to the Hardware and Upright Installation Procedures on Page 4.



### FoldPro Shelving Layout: High Roof, 159" Ext. Wheel Base (PM52) - PASSENGER SIDE

Fig. 11A

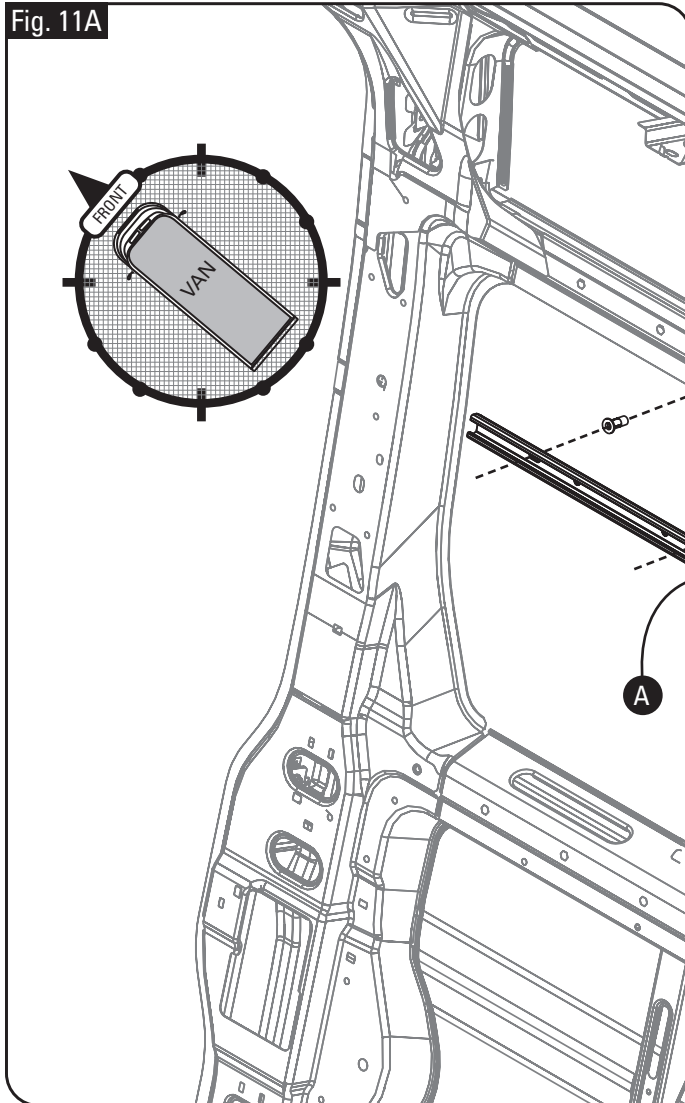
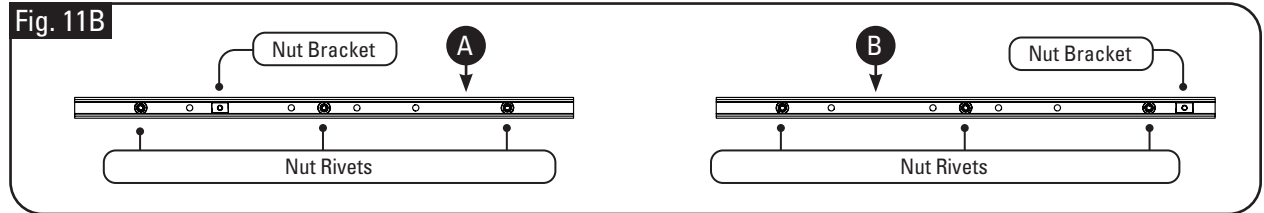

Fig. 11B



**Step 1:** Install Nut Rivets as shown (Fig. 11A & B).

**Step 2:** Install Hardware and Uprights in the sequence shown according to the Hardware and Upright Installation Procedures on Page 4.