

# PRIME DESIGN™

A Safe Fleet Brand

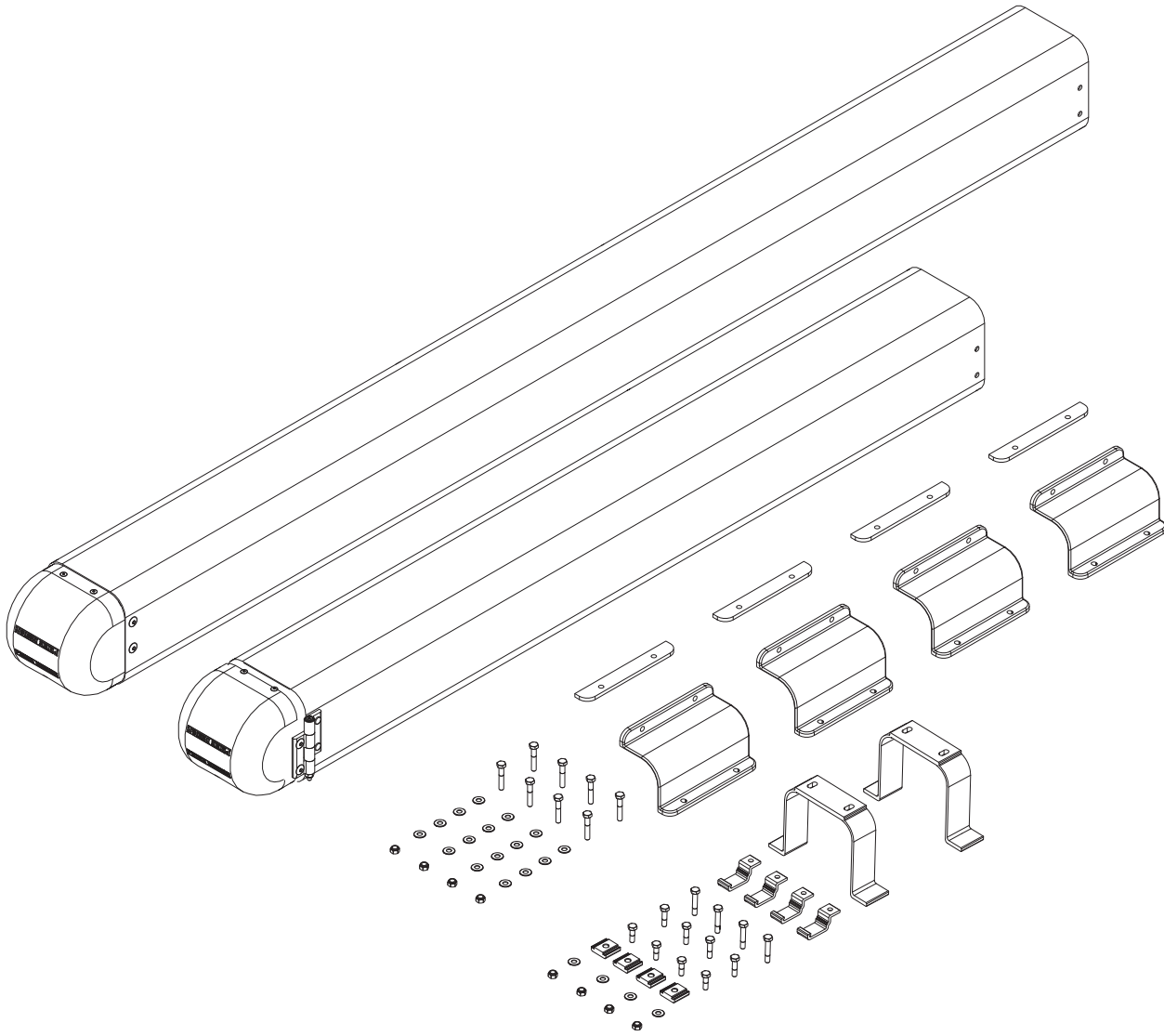

## *SPLICED CONDUIT TUBE ASSEMBLY*

PRIME DESIGN, A SAFE FLEET BRAND

Address: 580 Opperman Drive, Eagan, MN 55123 • Toll Free: 1.8.PRIME.RACK

Fax: 651-552-1799 • Email: [info@primedesign.net](mailto:info@primedesign.net) • Website: [www.primedesign.net](http://www.primedesign.net)

7008 CON

# CONTENTS OVERVIEW



**Note:** This Spliced Conduit Tube Assembly Kit is a direct fit for all Prime Design Gen 1 and 4 Ergoracks, AluRacks, and Low Profile Racks. This kit includes all new hardware, and discards all used or removed hardware if using as a replacement or for repair.

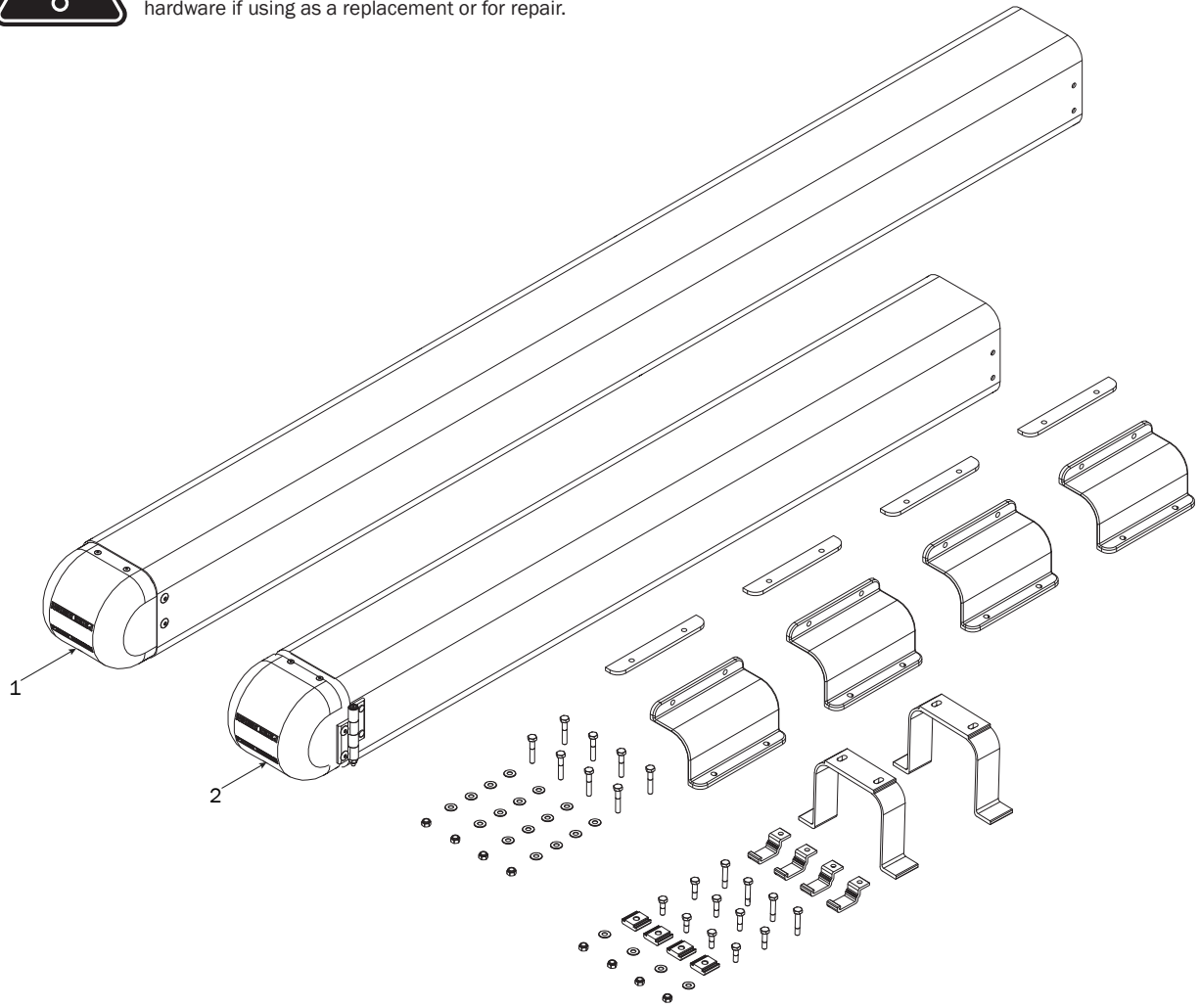

1—Front Conduit Tube Splice..... (Qty 1)

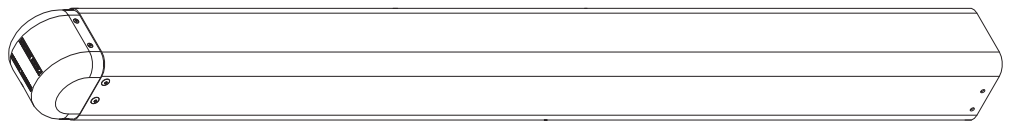

2—Rear Conduit Tube Splice ..... (Qty 1)

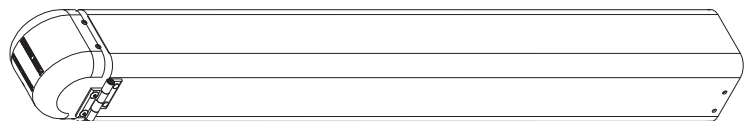

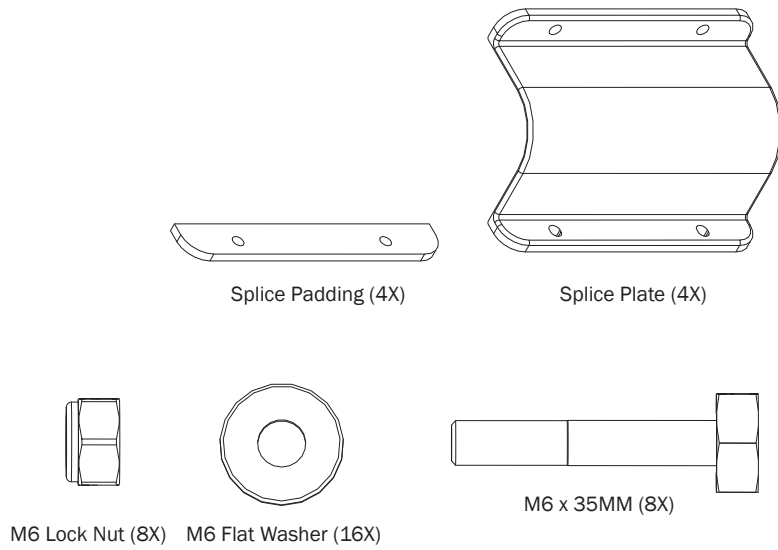

CON-8505 Conduit Carrier Mounting Kit

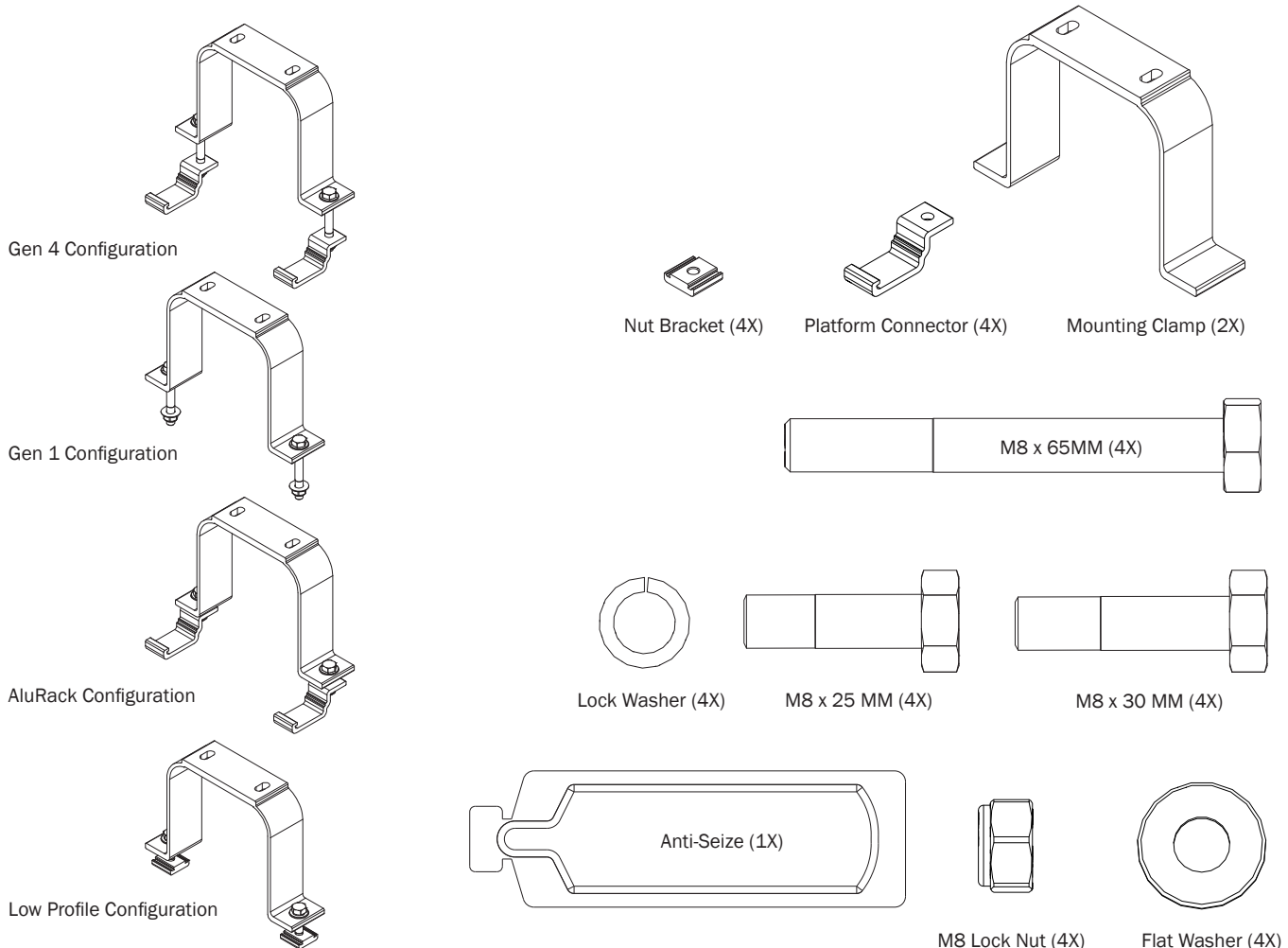

*SPLICED CONDUIT TUBE ASSEMBLY SEQUENCE*

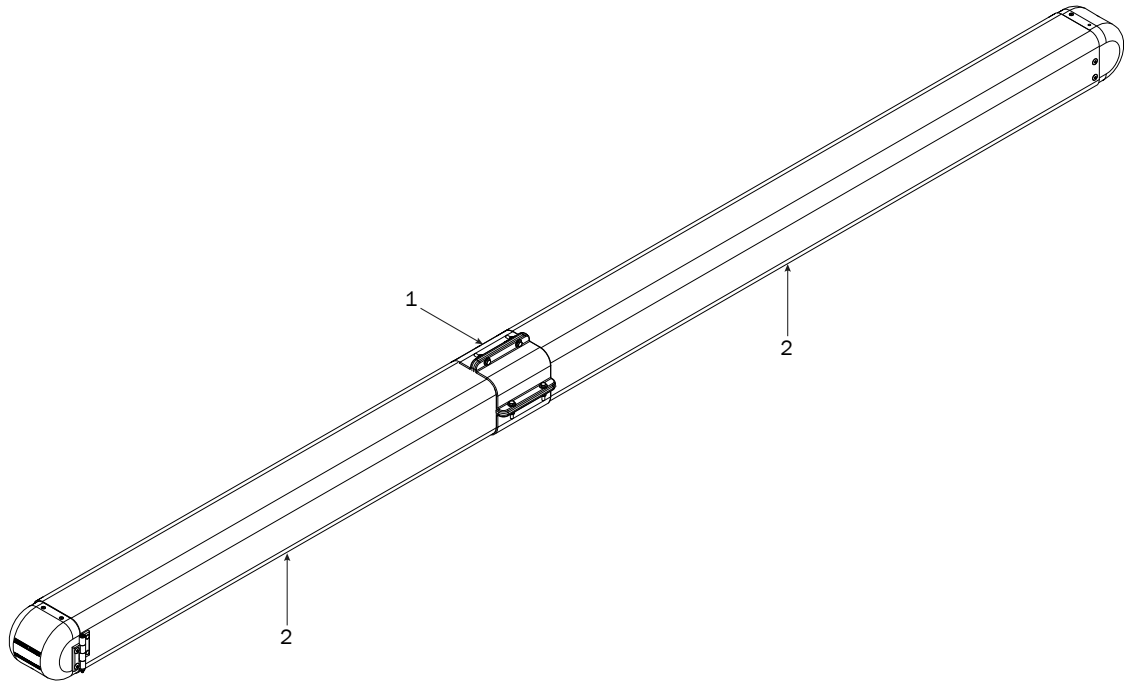

*CONDUIT TUBE SPLICE*

- 1** Assemble the left and right halves of the Splice Assembly. Do not tighten the M6 Bolts until step 2.2

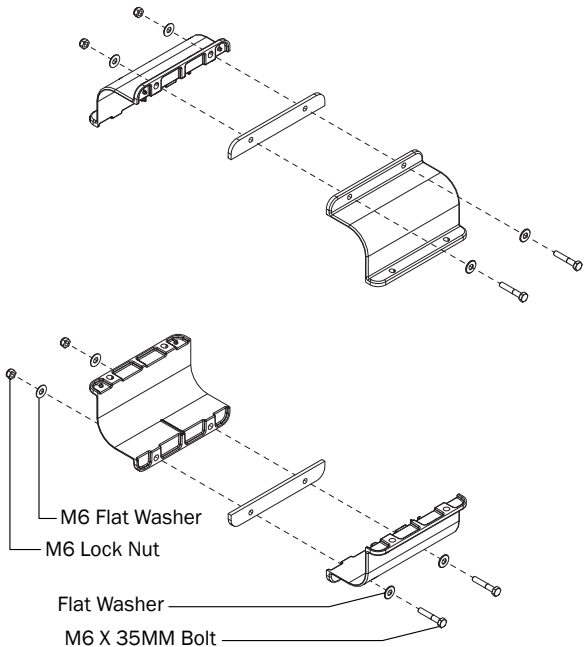

*CONDUIT TUBE*

- 2.1** Assemble the Front and Rear Conduit Splices, and the top and bottom halves of the Splice Assembly. Ensure the Conduit Tubes contact each other within the Tube Splice Assembly. Do not tighten the M6 hardware until step 2.2

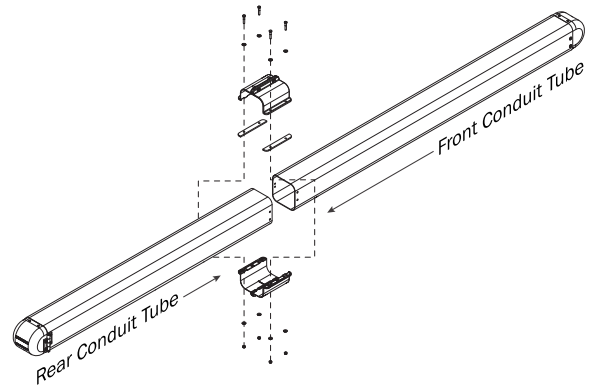

- 2.2** Torque M6 hardware to 60 in-lbs

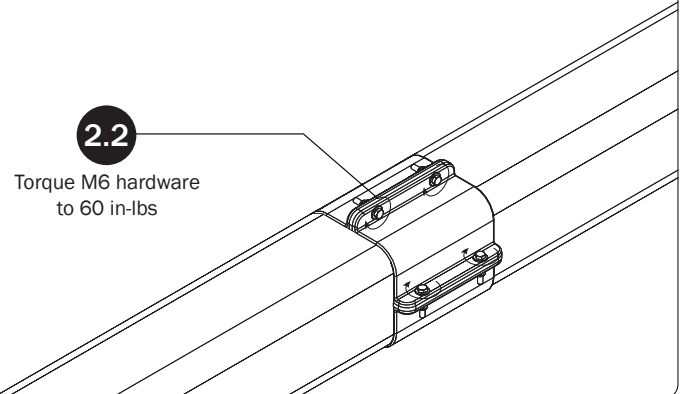

# GEN1 CONDUIT MOUNTING KIT INSTALLATION SEQUENCE

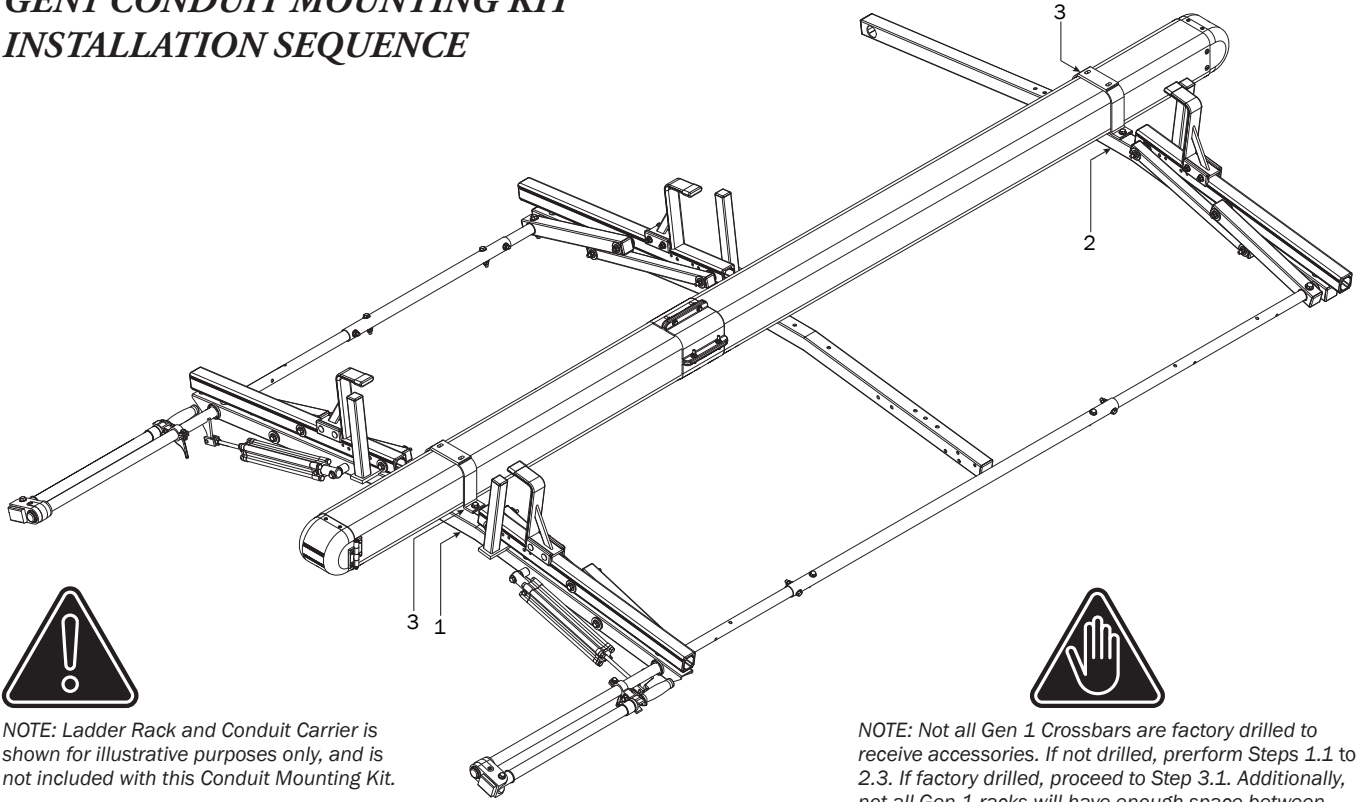

NOTE: Ladder Rack and Conduit Carrier is shown for illustrative purposes only, and is not included with this Conduit Mounting Kit.

This Conduit Mounting Kit contains only the parts needed to repair, replace, or add one Conduit Carrier.



NOTE: Not all Gen 1 Crossbars are factory drilled to receive accessories. If not drilled, perform Steps 1.1 to 2.3. If factory drilled, proceed to Step 3.1. Additionally, not all Gen 1 racks will have enough space between the Rotation Uppers to fit a Conduit Carrier. A minimum of 7.00" is required between the Uppers, and on the Crossbar's top, so measure prior to drilling to ensure there will be no Rotation interference.

## CROSSBAR PREPARATION-REAR

**1.1** Find the center of the top of Rear Crossbar between the inner bends. Using a grease pencil, mark the center, then measure out 3.50" to the left and right of that center mark and mark again using the grease pencil. The marked distances will measure 7.00" across as shown below.

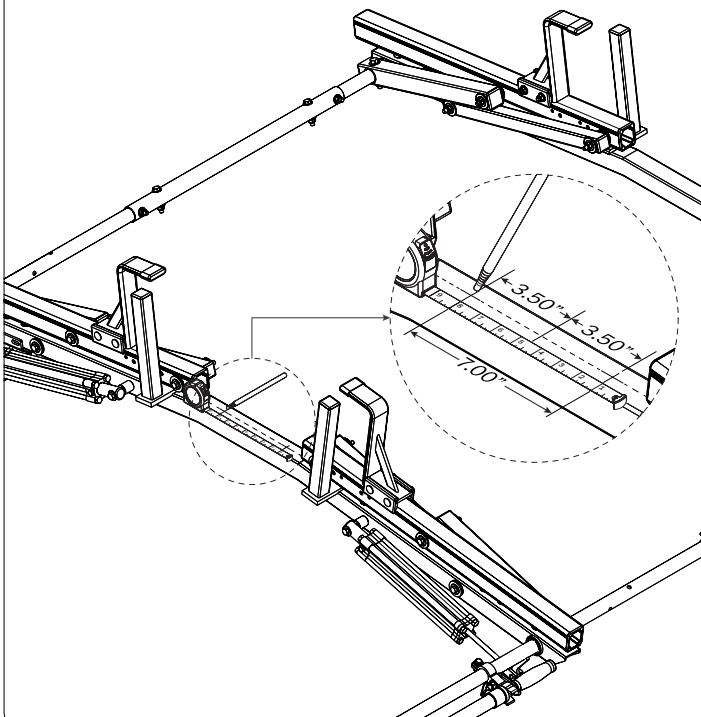

**1.2** Prior to drilling, mark a center line along the length of the Crossbar to ensure the holes are correctly centered.

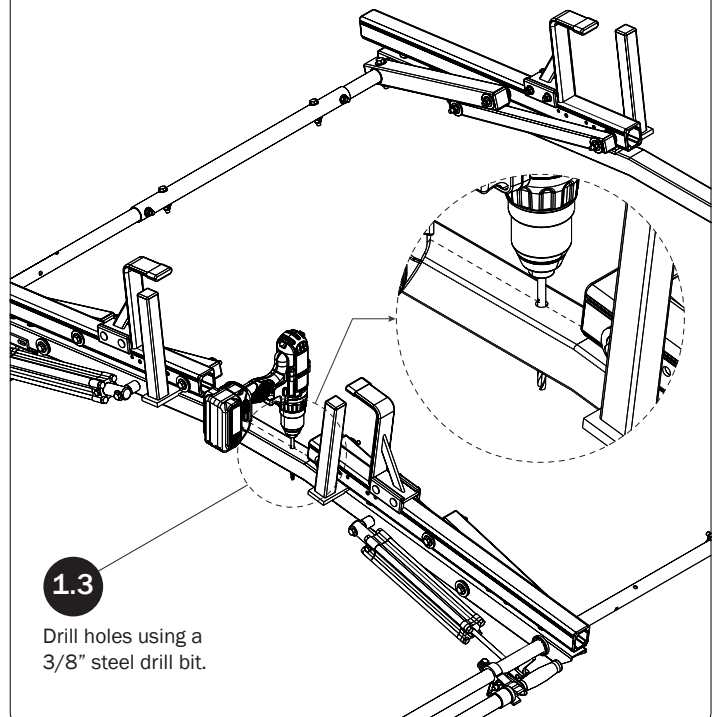

**1.3** Drill holes using a 3/8" steel drill bit.

### CROSSBAR PREPARATION-FRONT

**2.1** Find the center of the top of Front Crossbar between the inner bends. Using a grease pencil, mark the center, then measure out 3.50" to the left and right of that center mark and mark again using the grease pencil. The marked distances will measure 7.00" across as shown below.

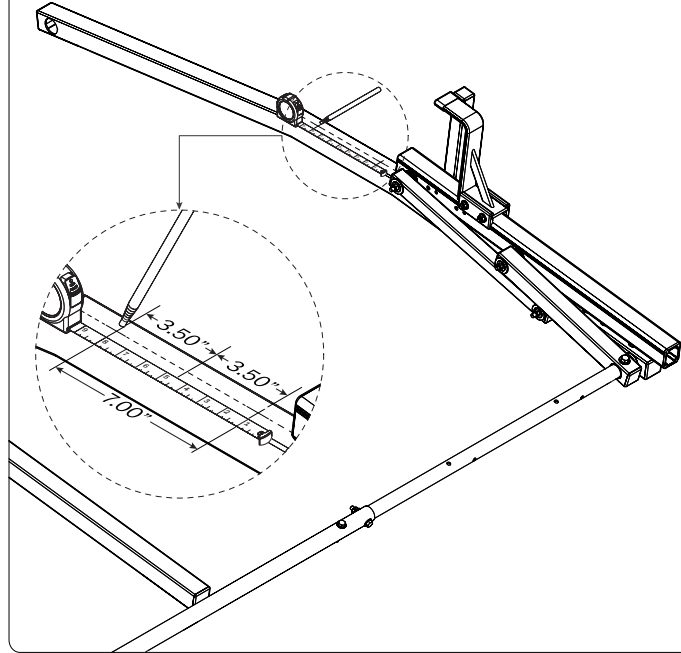

**2.2** Prior to drilling, mark a center line along the length of the Crossbar to ensure the holes are correctly centered.

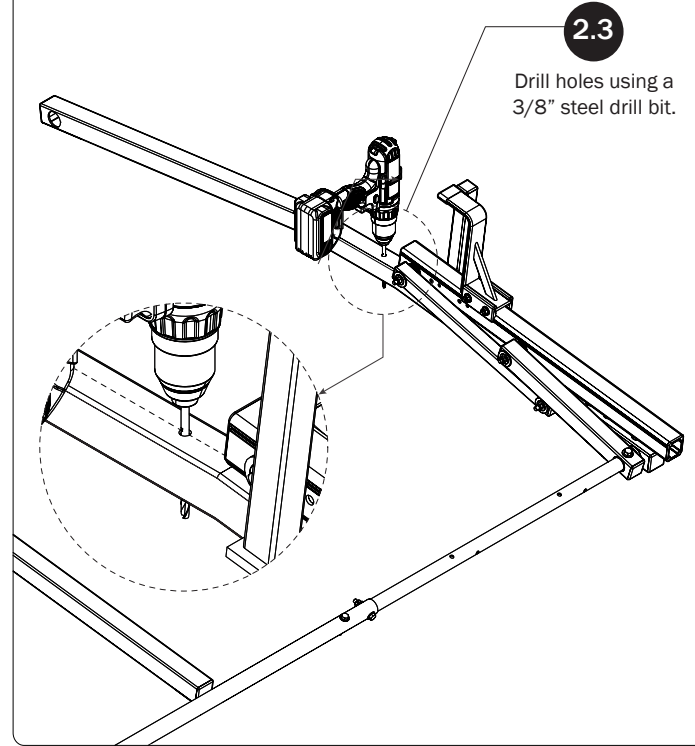

### CONDUIT CARRIER MOUNTINGS

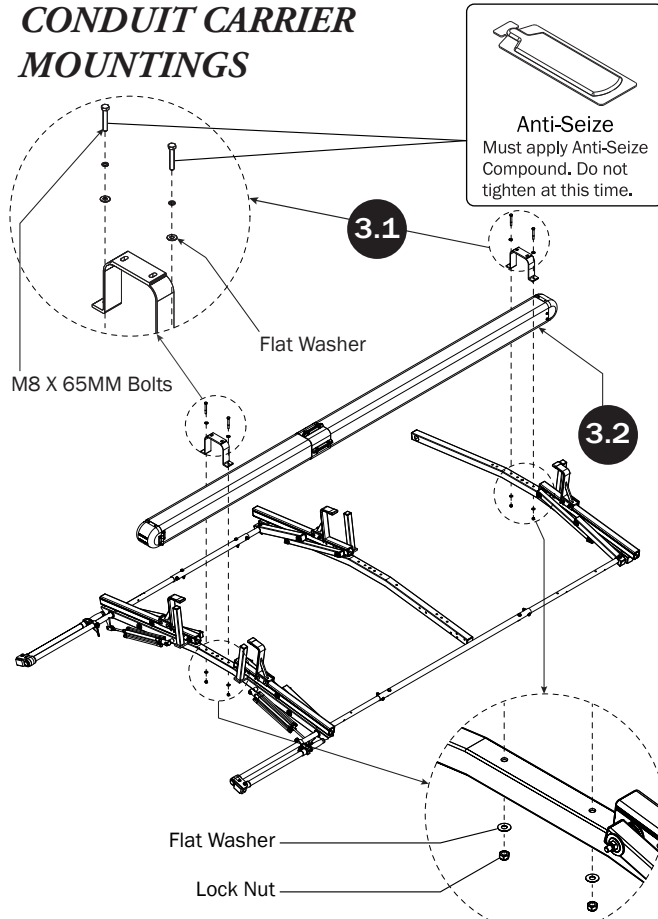

**3.3** Place Conduit Carrier onto Crossbars, then assemble Conduit Carrier Mountings on top securing the Conduit Carrier to the Crossbars using the provided hardware. Do not tighten the Mountings until Step 3.6.

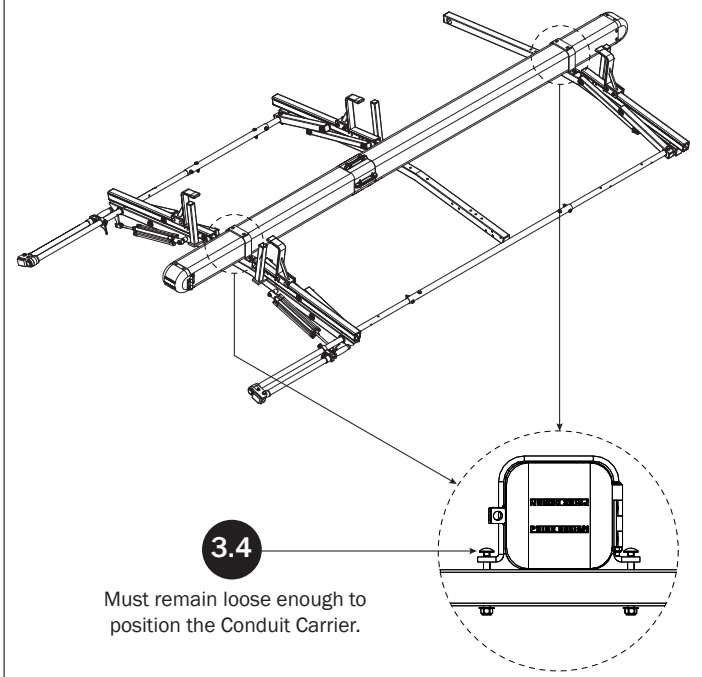

3.5

Center the front and rear of the Conduit Carrier evenly between the Left and Right Rotations. Position the back end of the Conduit Carrier according to your rack model, but no further back than the end of the Drive Shaft.

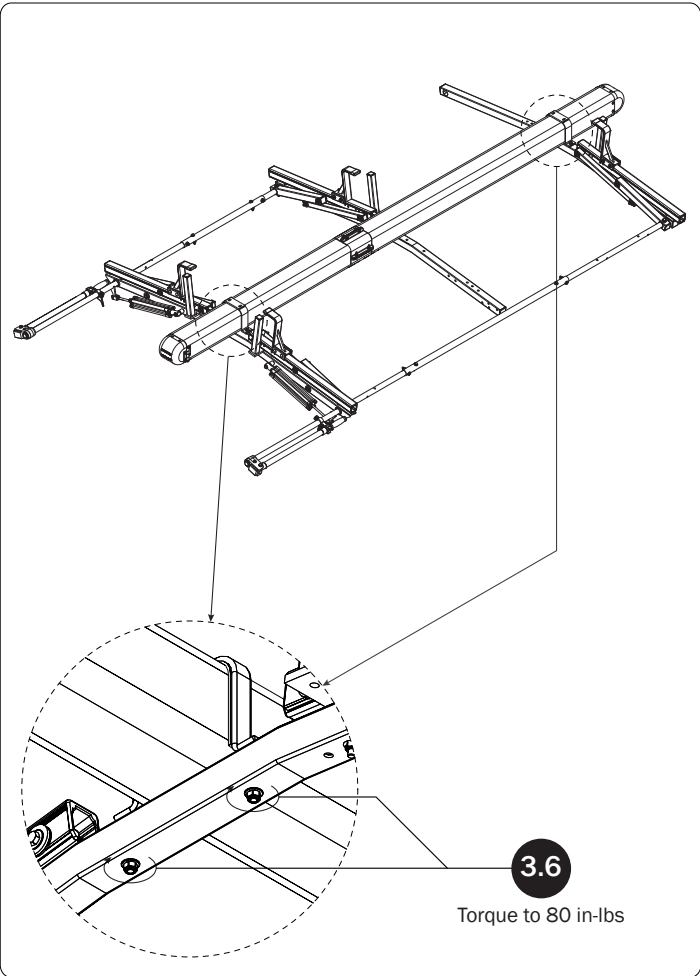
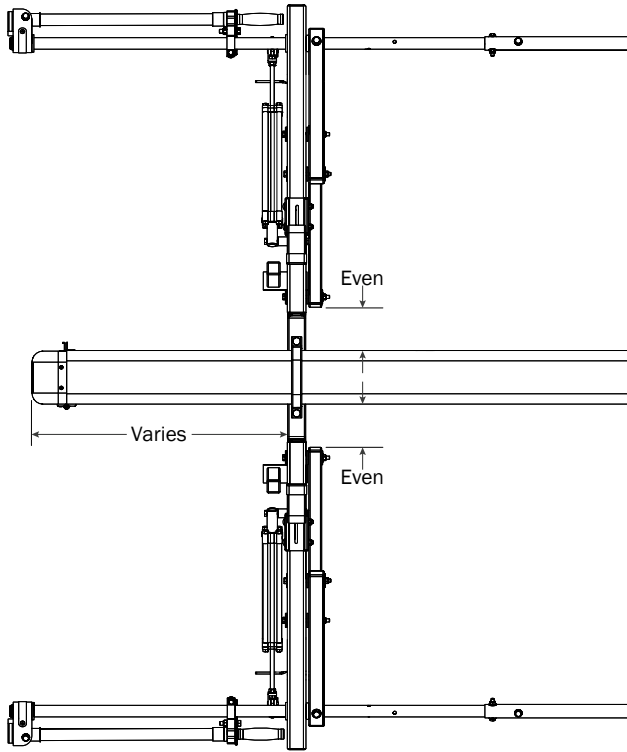

3.6  
Torque to 80 in-lbs

### GEN4 CONDUIT MOUNTING KIT INSTALLATION SEQUENCE

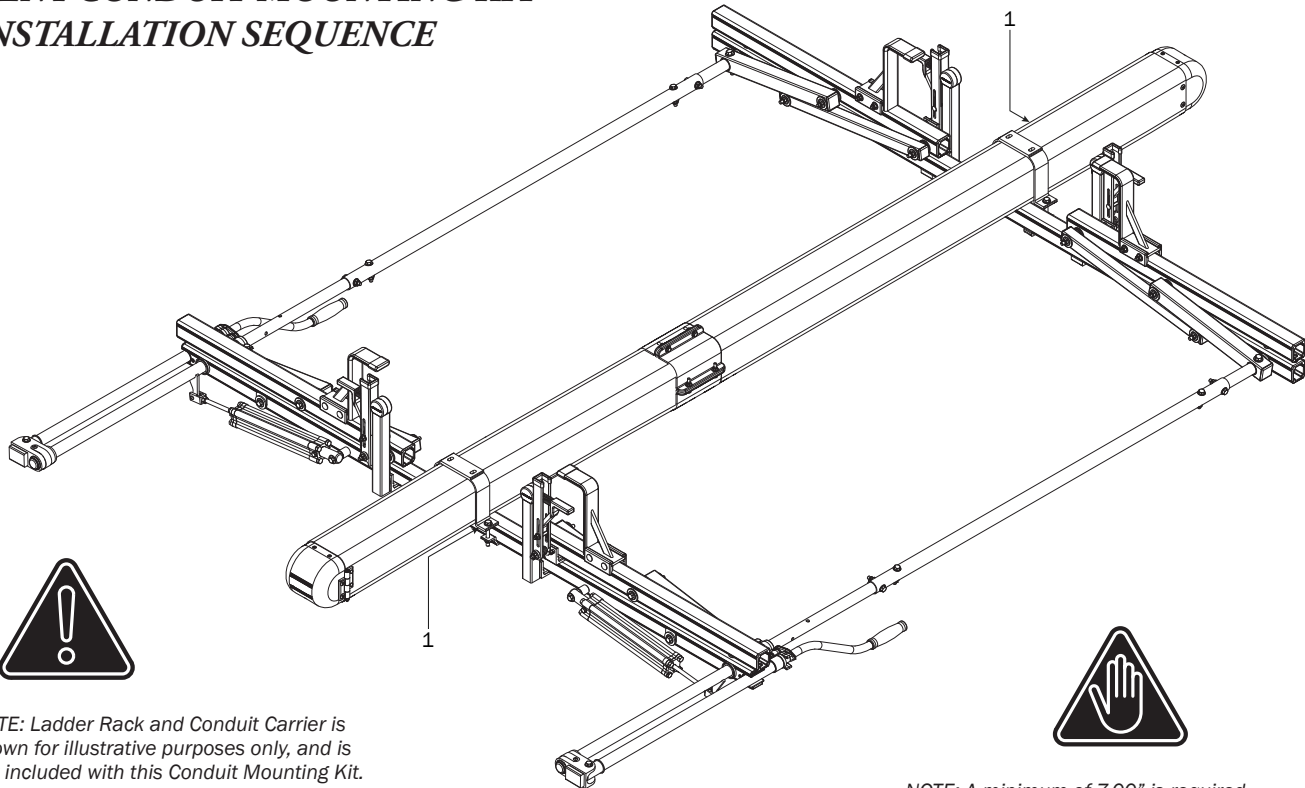

NOTE: Ladder Rack and Conduit Carrier is shown for illustrative purposes only, and is not included with this Conduit Mounting Kit.

This Conduit Mounting Kit contains only the parts needed to repair, replace, or add one Conduit Carrier.

NOTE: A minimum of 7.00" is required between the Uppers, and on the Crossbar's top, so measure to ensure there will be no Rotation interference.



## CONDUIT CARRIER MOUNTINGS

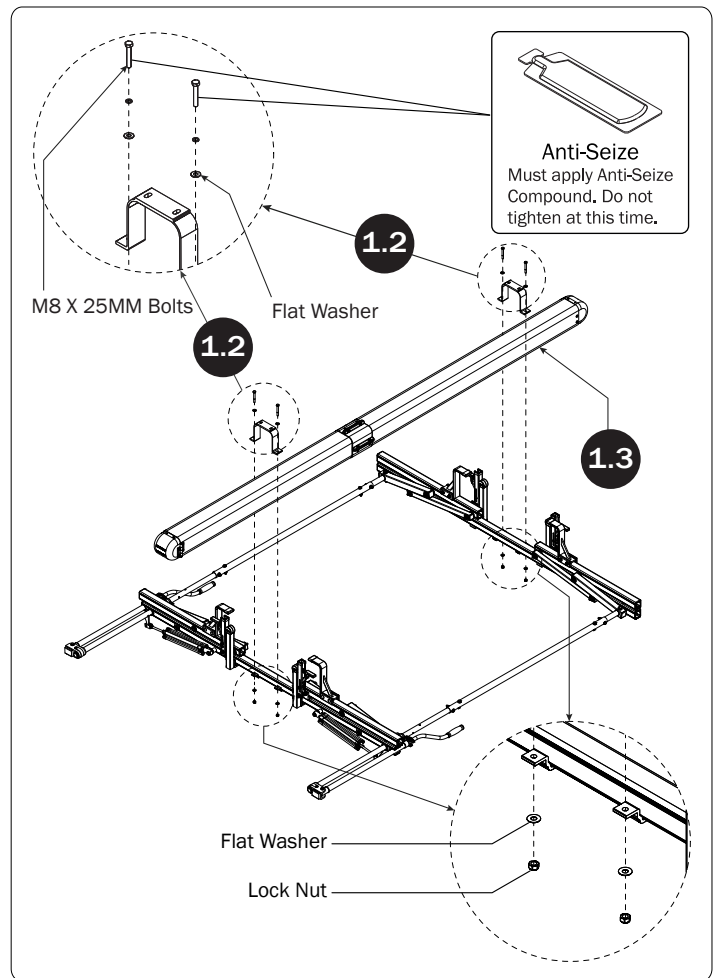
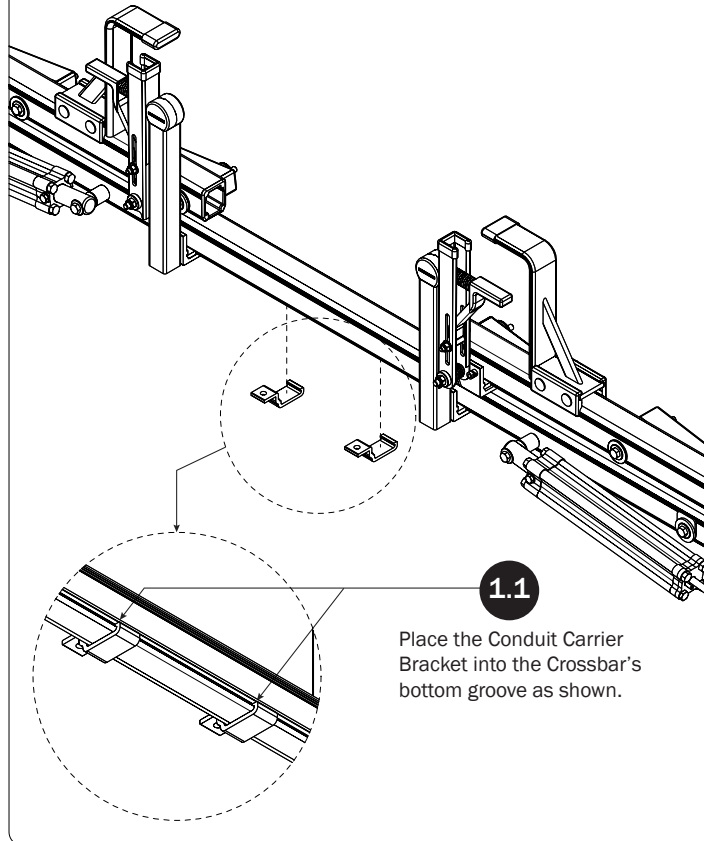

**1.4** Center the front and rear of the Conduit Carrier evenly between the Left and Right Rotations. Position the back end of the Conduit Carrier according to your rack model, but no further back than the end of the Drive Shaft.

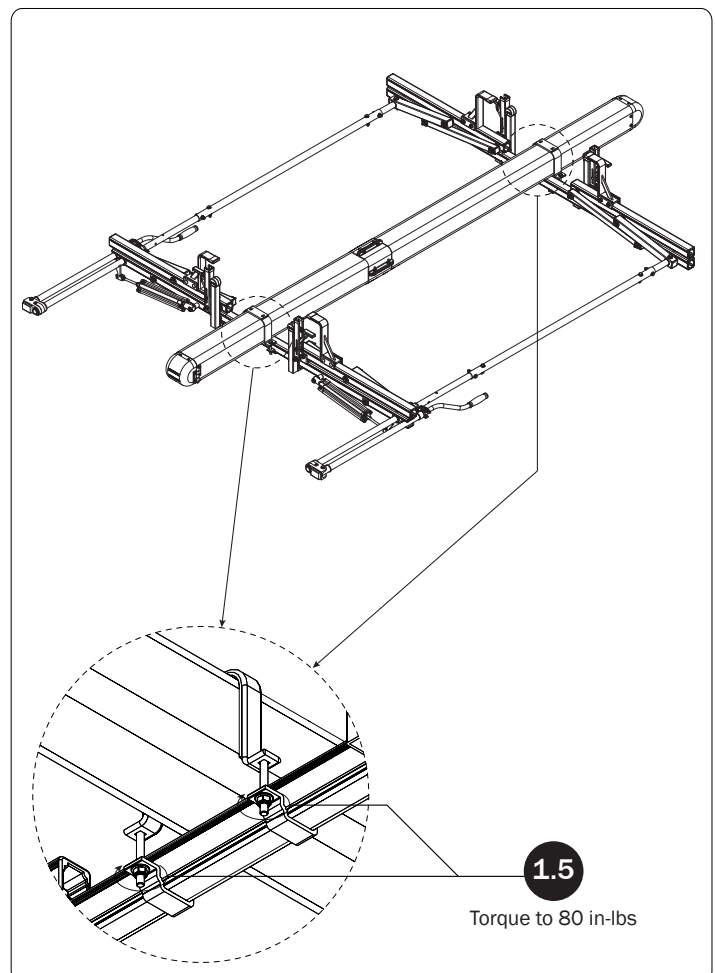
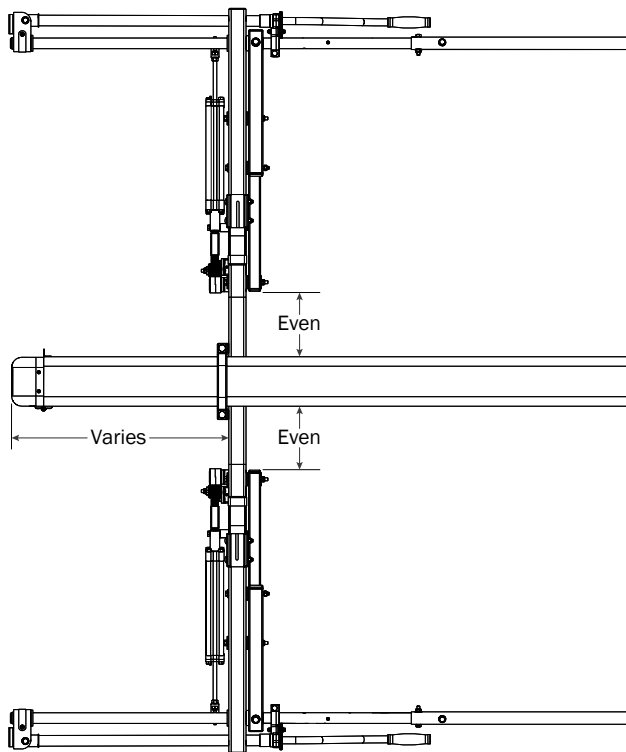



# ALURACK CONDUIT MOUNTING KIT INSTALLATION SEQUENCE

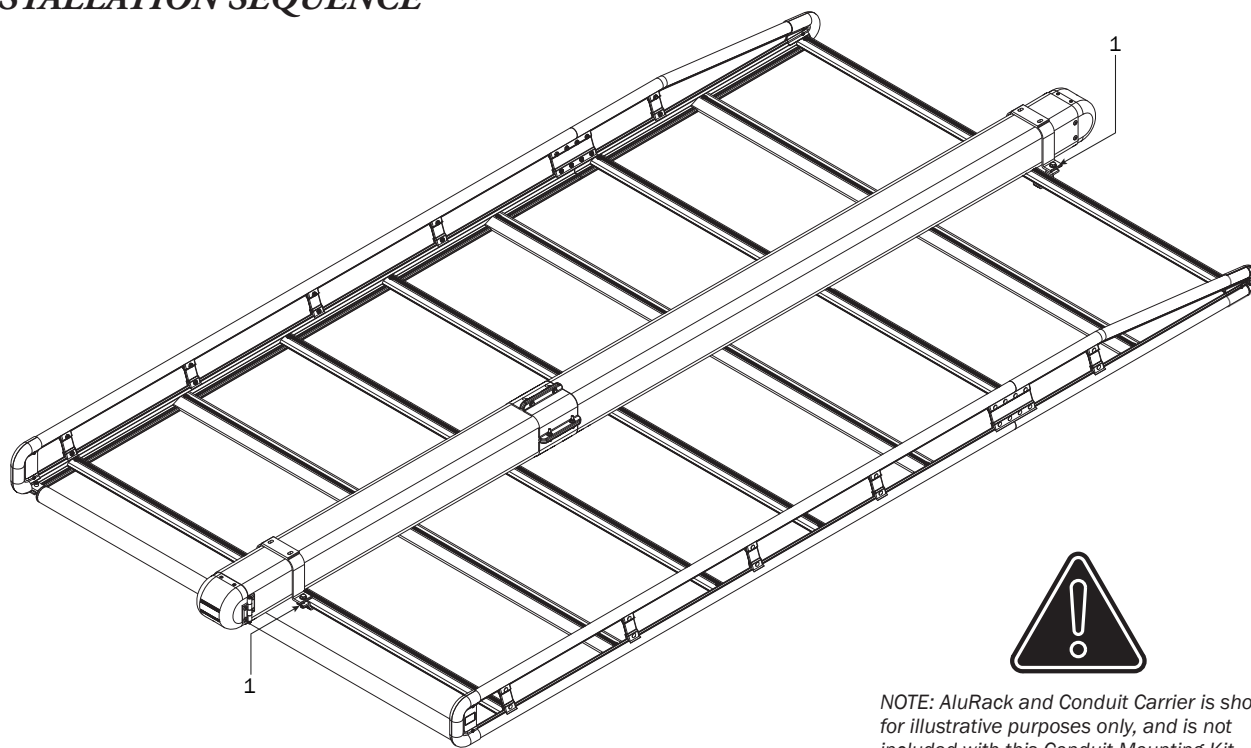

**NOTE:** AluRack and Conduit Carrier is shown for illustrative purposes only, and is not included with this Conduit Mounting Kit.

This Conduit Mounting Kit contains only the parts needed to repair, replace, or add one Conduit Carrier.

## CONDUIT CARRIER MOUNTINGS

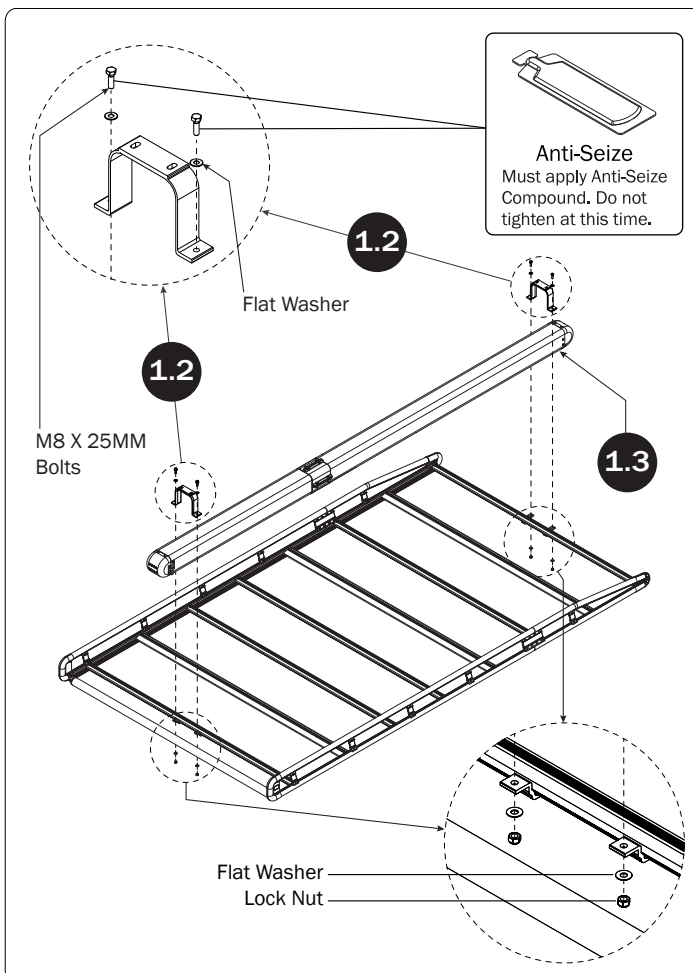
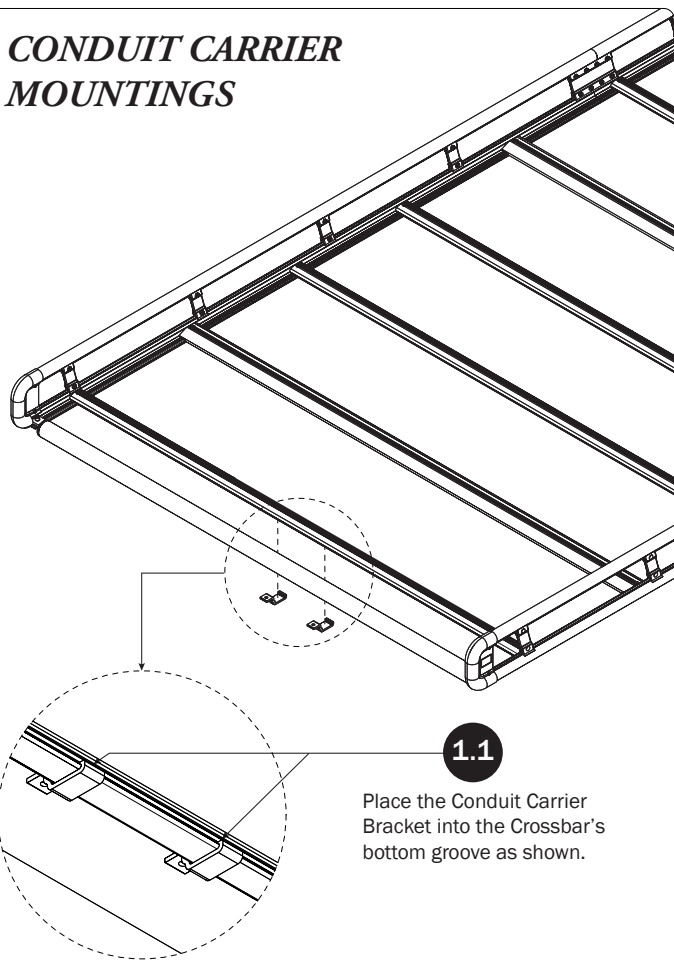

**1.4** Position the Conduit Carrier anywhere between the side rails ensuring the Conduit Mountings to not interfere with the AluRack Mounting Brackets attaching the rack to the vehicle roof. The Conduit Carrier must not exceed the rear most end of the AluRack side rail.

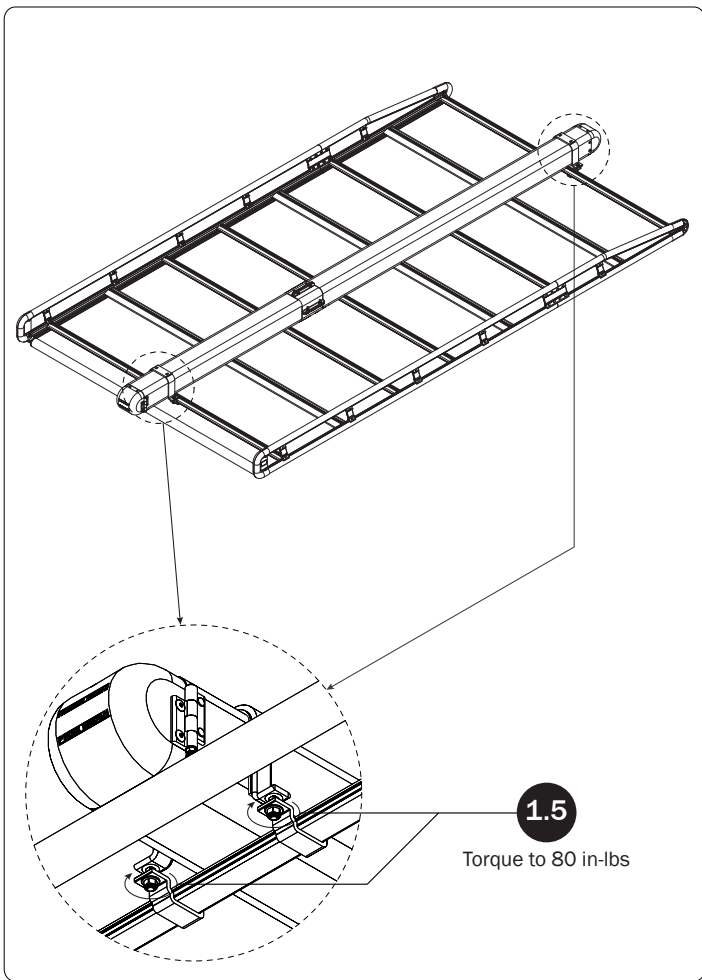
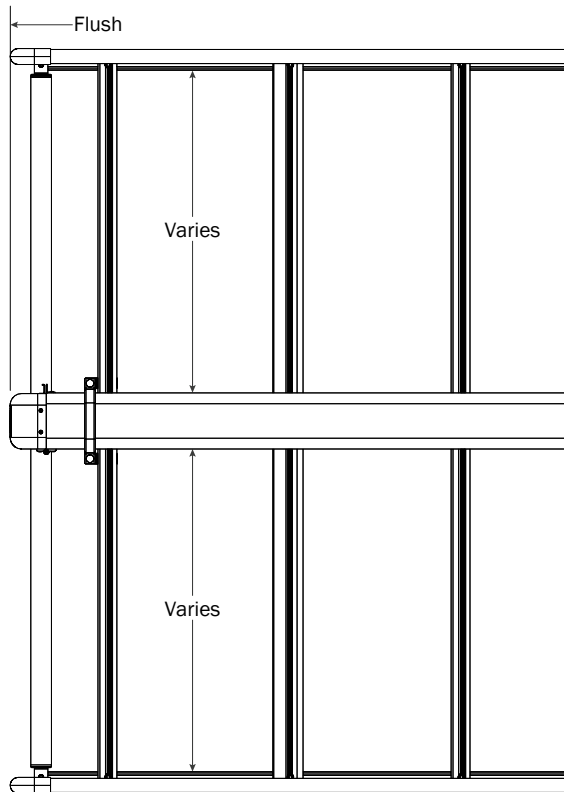

**LOW PROFILE MOUNTING KIT  
INSTALLATION SEQUENCE**

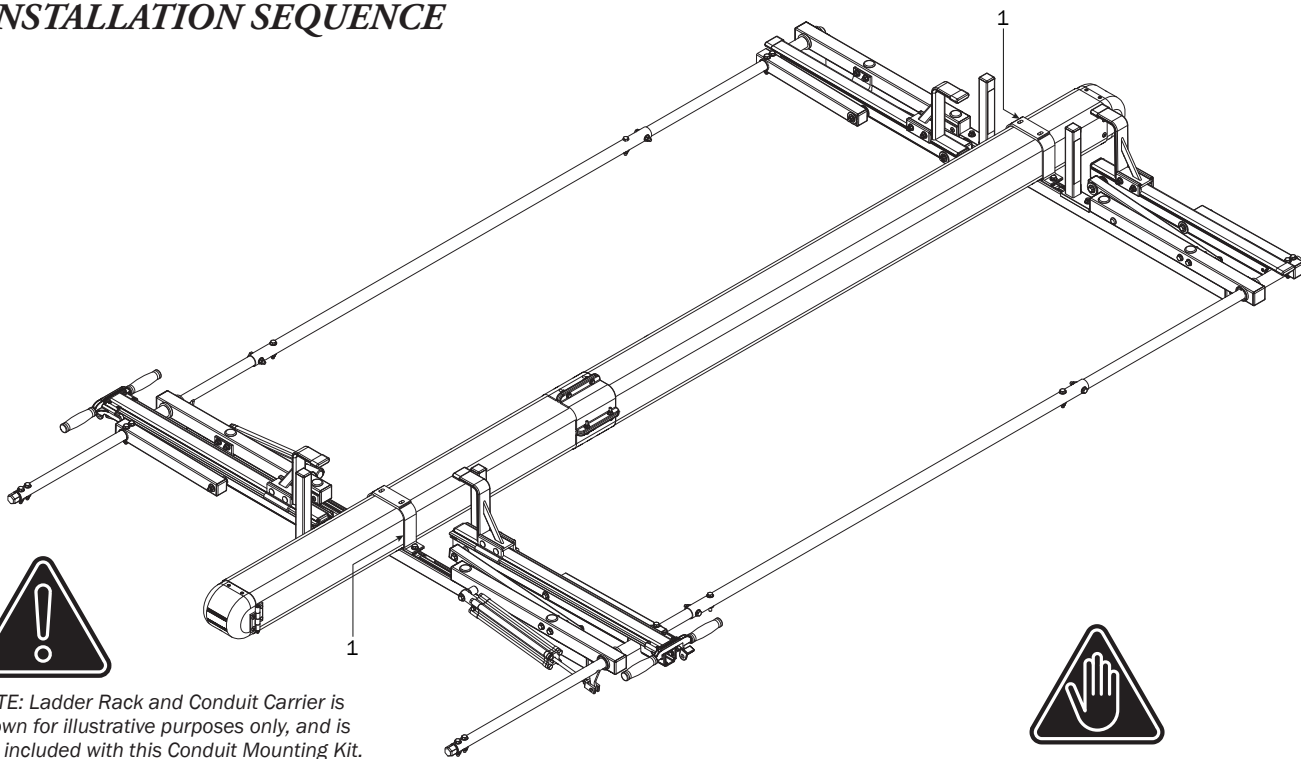

**NOTE:** Ladder Rack and Conduit Carrier is shown for illustrative purposes only, and is not included with this Conduit Mounting Kit.

This Conduit Mounting Kit contains only the parts needed to repair, replace, or add one Conduit Carrier.

**NOTE:** A minimum of 7.00" is required between the Uppers, and on the Crossbar's top, so measure to ensure there will be no Rotation interference.

## CONDUIT CARRIER MOUNTINGS

- 1.1** Place the Conduit Carrier Nut Brackets into the Front and Rear Crossbars as shown.

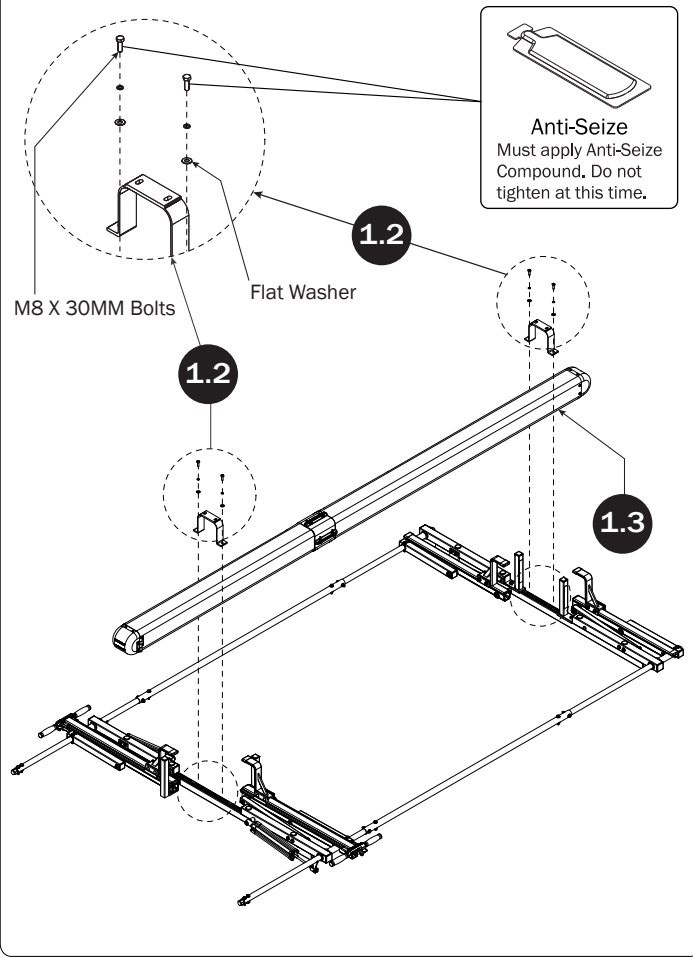
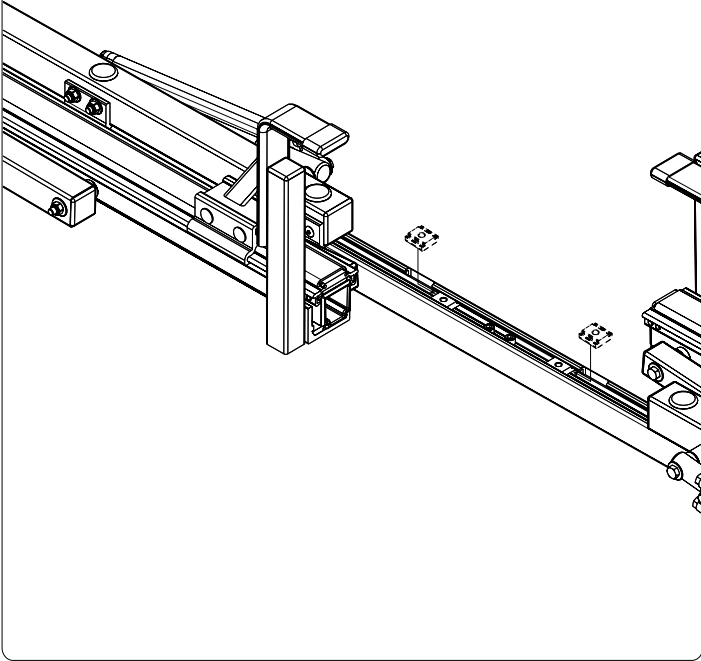

- 1.4** Center the front and rear of the Conduit Carrier evenly between the Left and Right Rotations. Position the back end of the Conduit Carrier according to your rack model, but no further back than the end of the Drive Shaft.

