

## ASH-8033

### Strobe/Go-Light Holder

Dimensional Specifications on Page 2

#### Configuration as shown:

Crossbar Pedestal Light Holder, US Gen1-4

Finish: White Powder Coat

Rack Weight (empty): 2.80 lbs

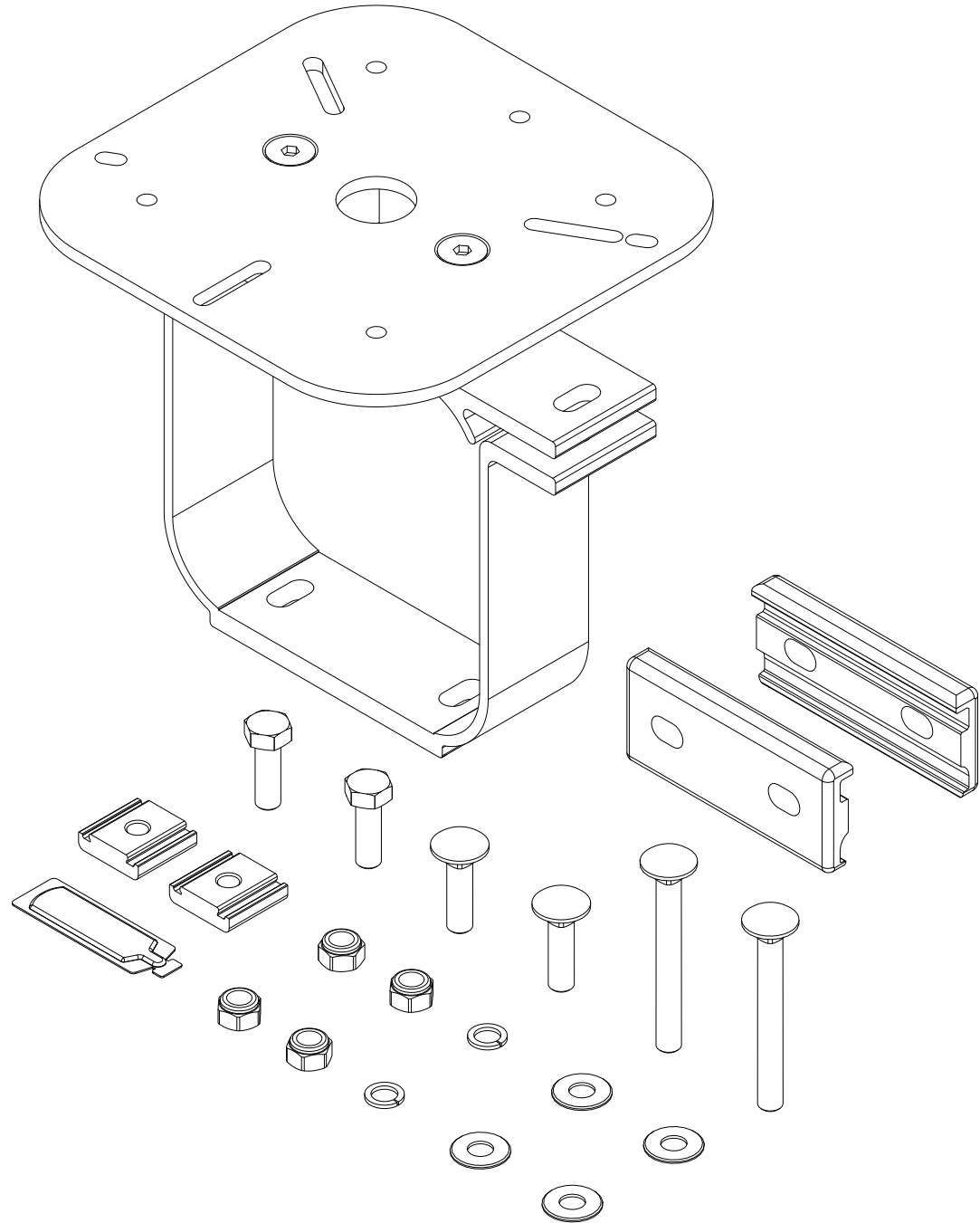

## ASH-8033

### Strobe/Go-Light Holder

Approximate dimensions as shown:

A: Mounting Plate Width/Depth .....	6.75"
B: Mounting Holes (2 Screws Diagonal) .....	6.92"
C: Mounting Circumcenter (Outer) .....	6.40"
D: Mounting Diameter (4 Screws) .....	5.65"
E: Mounting Circumcenter (Inner) .....	3.90"
F: Mounting Hole Spacing (Square) .....	4"
G: Mounting Hole Spacing (2 Screws) .....	3"
H: Mounting Hole Diameter .....	.23/64"
I: Wiring Access .....	7/8"
J: Screw Slot Length, Long (3 Total) .....	1"
K: Mounting Hole (5 Total) .....	1/4"
L: Screw Slot Length, Short (2 Total) .....	5/32"
M: Holder Total Width .....	8.00"
N: Total Holder Height .....	7.50"
O: Conduit Carrier Width .....	5.25"
P: Holder Base Width .....	4.00"

