

PRIME DESIGN™

A Safe Fleet Brand

AR1916

AluRack, Metris 2016

Configuration as shown:

Anodized Aluminum
Option Rack Weight (empty): 54 lbs

*Callouts in this Configuration Overview indicate full module assemblies only.

For details on individual parts, please refer to the linked Module Overviews below.

AR1916 (Clear Anodized)

A: [FBM-1015-BLK Mounting System](#)
B: [AR-2103 112" Side Rail Feature](#)
C: [AR-2002 59" Crossbar Feature](#)

AR1916-BLK (Black Anodized)

A: [FBM-1015-BLK Mounting System](#)
B: [AR-2103-BLK 112" Side Rail Feature](#)
C: [AR-2002-BLK 59" Crossbar Feature](#)

[Modular Assembly Manuals](#)

AluRack—Load specifications:

Check vehicle manufacturer recommendations for roof capacity weight limits.

USOV-AR1916-US01 Rev-B 0520

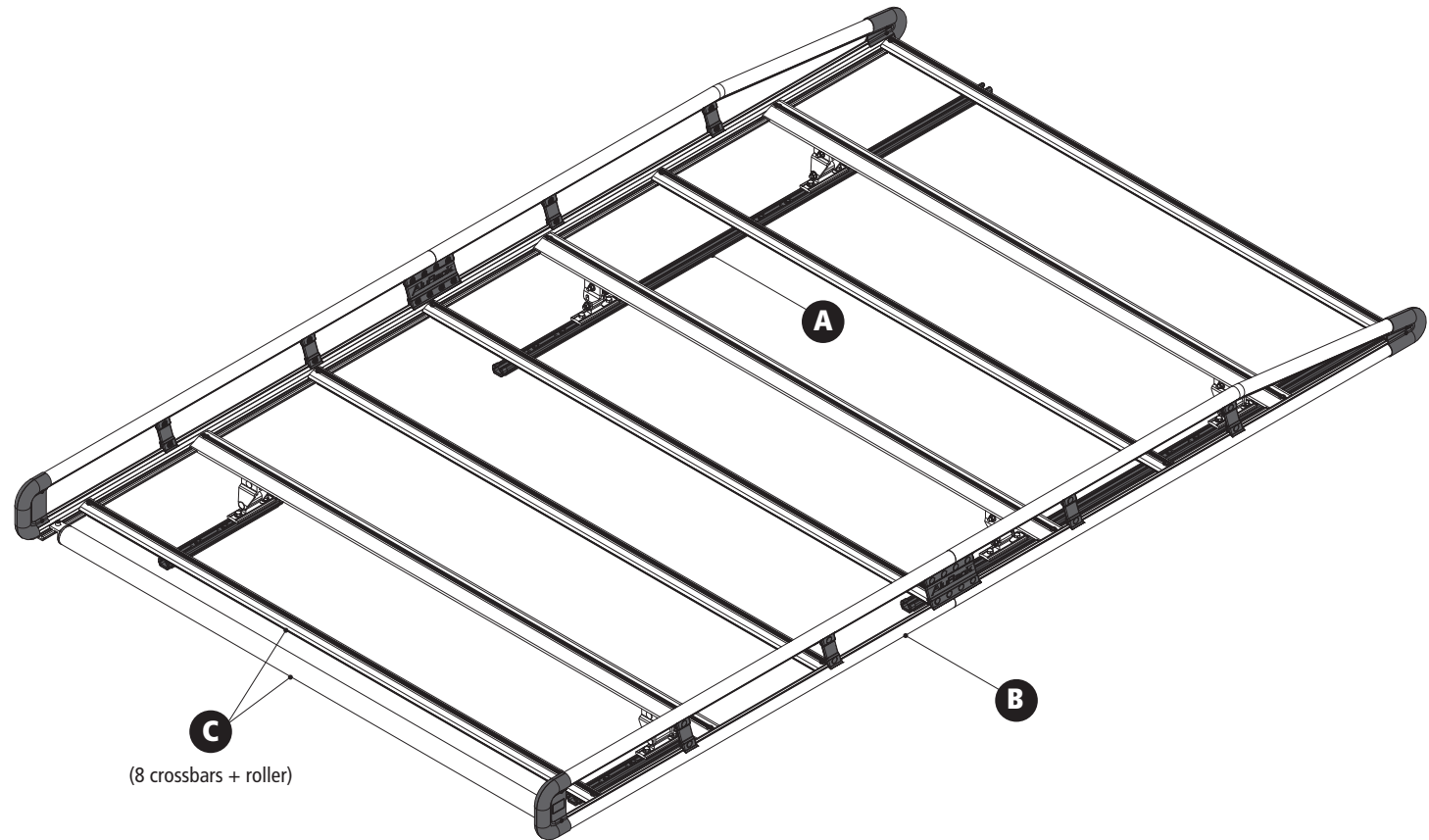

AR1916

Metris 2016

Approximate dimensions as shown:

- A: Rack Width 61"
- B: Rack Length 116"
- C: Rack Height 11"

Compatible Accessories Available (Sold Separately)

- Ladder Clamp Down..... [ACX-AXC Series](#)
- Retractable Ratchet Tie-Down.....[ACC-8000](#)
- 8'–12' Conduit Tubes.....[CON Series](#)
- WorkPro LED Lighting..... [LED Series](#)
- Systems and Safety Components.....[RVS Series](#)
- Safety monitoring.....[DS2 Series](#)
- Rear Access Ladder.....[AAL Series](#)

