

PRIME DESIGN™

A Safe Fleet Brand

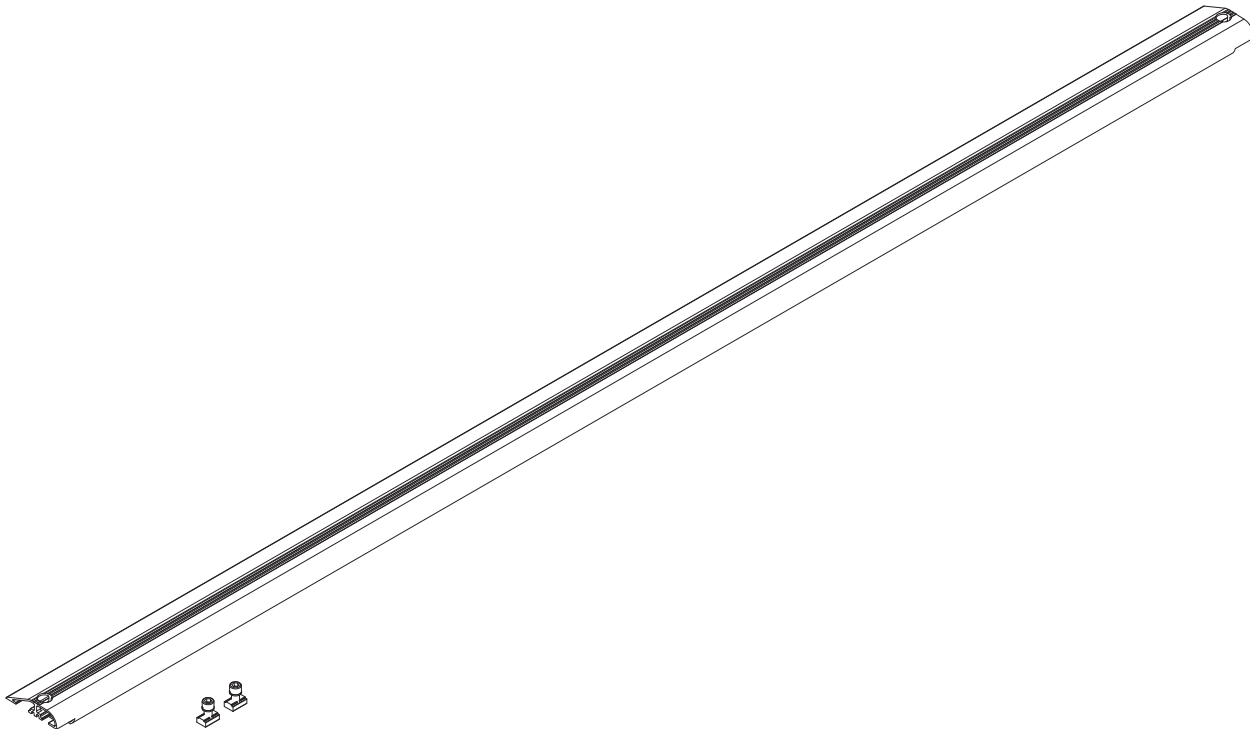

MODELS AVAILABLE:

AR-2012 (CLEAR ANODIZED)

AR-2012-BLK (BLACK ANODIZED)

AR-2012 AluRack Crossbar Module, 59" Kit

Page 2	Packaging Contents
Page 2-3	Crossbar Installation (Retrofit on Existing Rack)
Page 3	Crossbar Configurations—Maximum Spacing
Page 4-7	Full Rack Assembly

PRIME DESIGN, A SAFE FLEET BRAND

Address: 580 Opperman Drive, Eagan, MN 55123 • Toll Free: 1.8.PRIME.RACK
Fax: 651-552-1799 • Email: info@primedesign.net • Website: www.primedesign.net

AR-2012

CONTENTS OVERVIEW

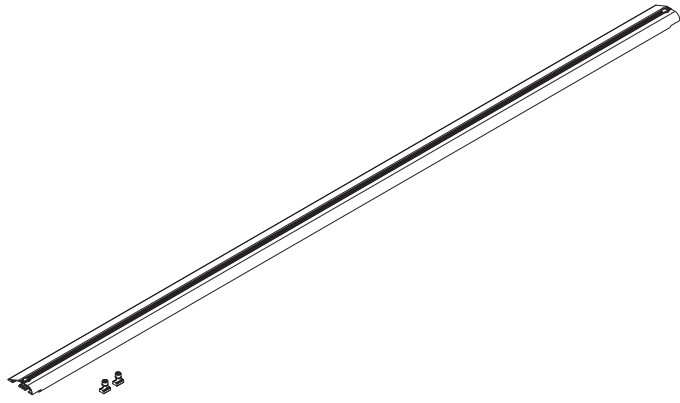

AluRack Heavy Duty Crossbar (Qty 1)
With hardware, 59.00”
Clear or Black (BLK), Anodized



Roller Hardware (Qty 1)

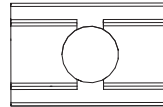

M8 Strip Nut (2X)

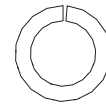

M8 Lock Washer (2X)

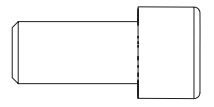

M8 Cap Head Bolt (2X)

CROSSBAR INSTALLATION (RETROFIT ON EXISTING RACK)

The AluRack shown below is for illustrative purposes only, and shows a combination of Standard and Heavy Duty Crossbars. Spacing and sizing will vary according to customer needs.

- 0.1 Install the Strip Nut from your Heavy Duty Crossbar Hardware Kit into the front Side Rails as shown.

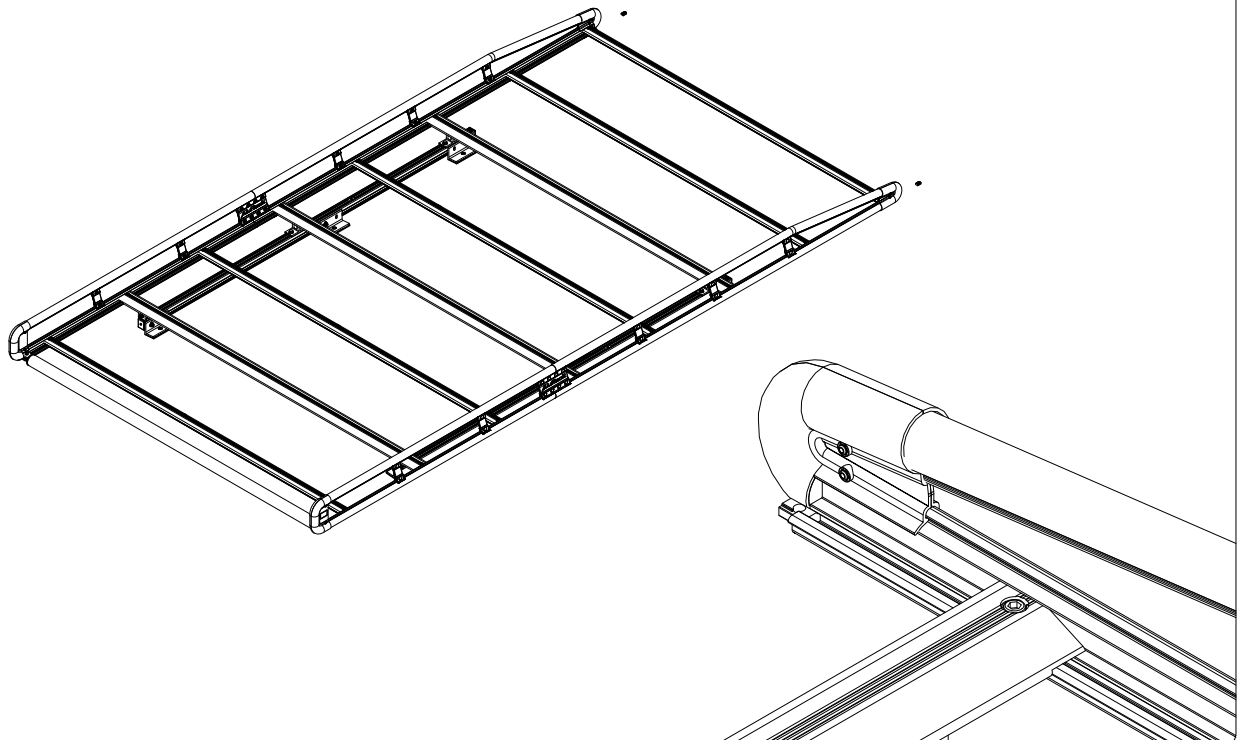

CROSSBAR ADDITION (OR REPLACEMENT)

NOTE: Heavy Duty Crossbars are used for mounting your rack to the FBM, and must be in the original mounting position. The rest of the configuration may be adjusted to customer needs.

The AluRack shown below is for illustrative purposes only, and shows the original Crossbars with a new Crossbar in addition. The new Crossbar may also be used to replace a Standard or Heavy Duty Crossbar as needed.

- 0.2** Remove Hardware and existing Crossbars that will be affected by your installation as shown in the example below.

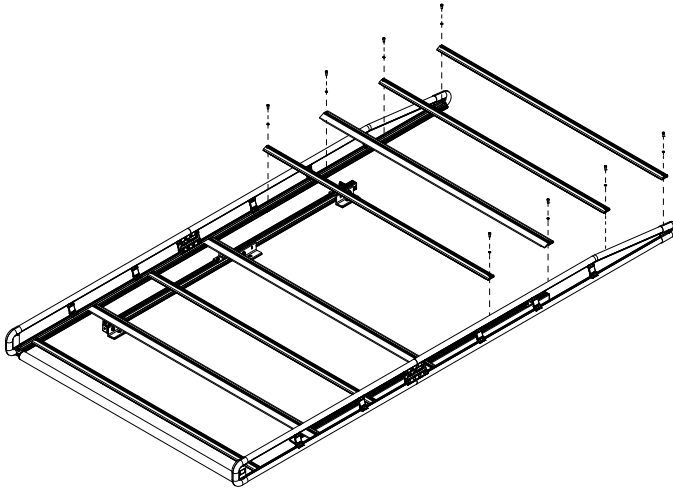

- 0.3** Reinstall existing and new Crossbars into the Strip Nuts as shown in the example below. Refer to the Crossbar Configurations Chart in Fig. 1 and ensure correct desired order and distances, then torque to 90 in-lbs.

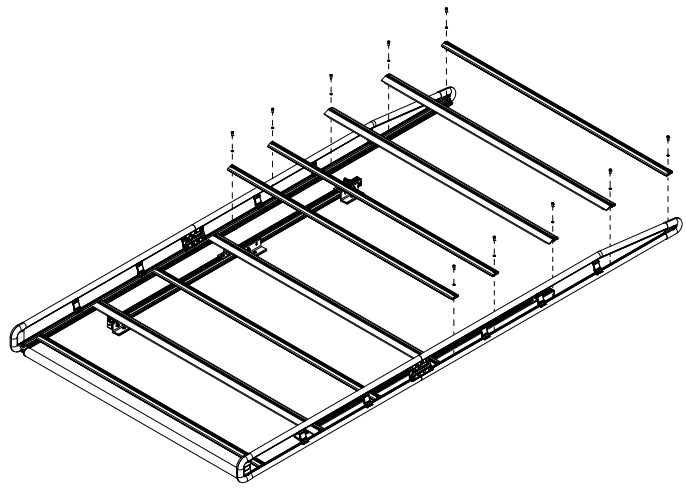

CROSSBAR CONFIGURATIONS

The Roller on all AluRacks must be mounted with the Roller Brackets Flush to the Rear Siderail ends. Maximum Bolt Spacing between Crossbars and Roller is 24.00". When mounting to an FBM (sold separately), Crossbar Mounts must attach to Heavy Duty Crossbars only. It is recommended to determine your Crossbar pattern (Standard vs Heavy Duty) before installing them into your Strip Nuts to ensure proper order of use.

*The AluRack shown in Fig.1 is for Illustrative Purposes only. Side Rail Sizes vary according to customer sizing needs - See respective AR Side Rail Kit Manual to build your Side Rails.

Fig. 1

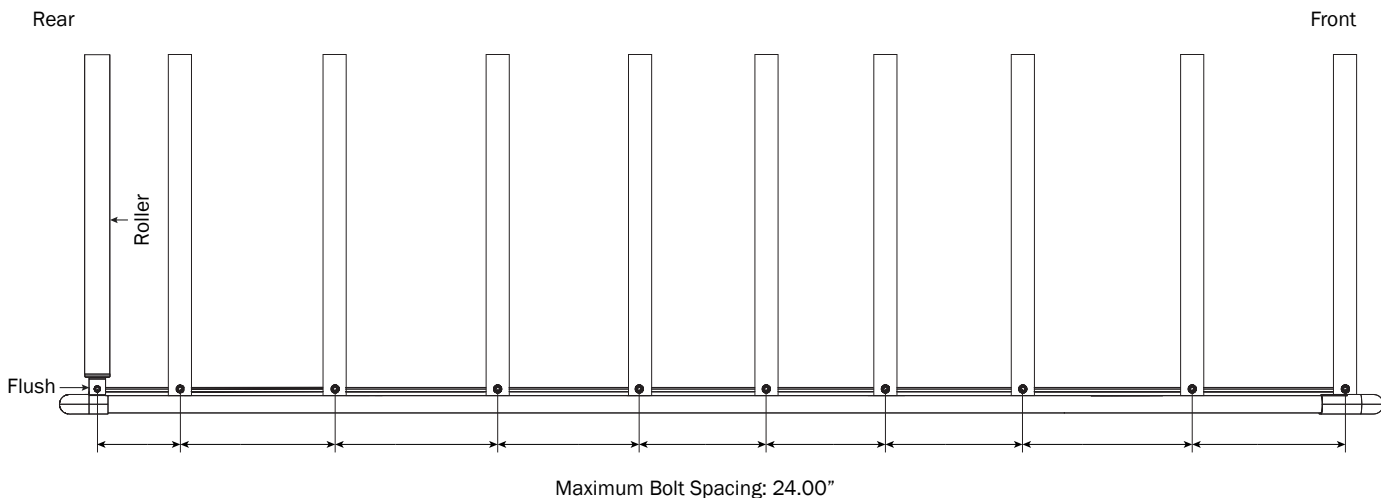

STRIP NUT INSTALLATION (FULL RACK ASSEMBLY)

NOTE: The AluRack shown below is for illustrative purposes only, and shows a combination of Standard and Heavy Duty Crossbars. Spacing and sizing will vary according to customer needs (see Crossbar Configurations Chart on previous page). Maximum bolt spacing between Roller and Crossbars is 24.00". Crossbar Mounts must attach to Heavy Duty Crossbars only.

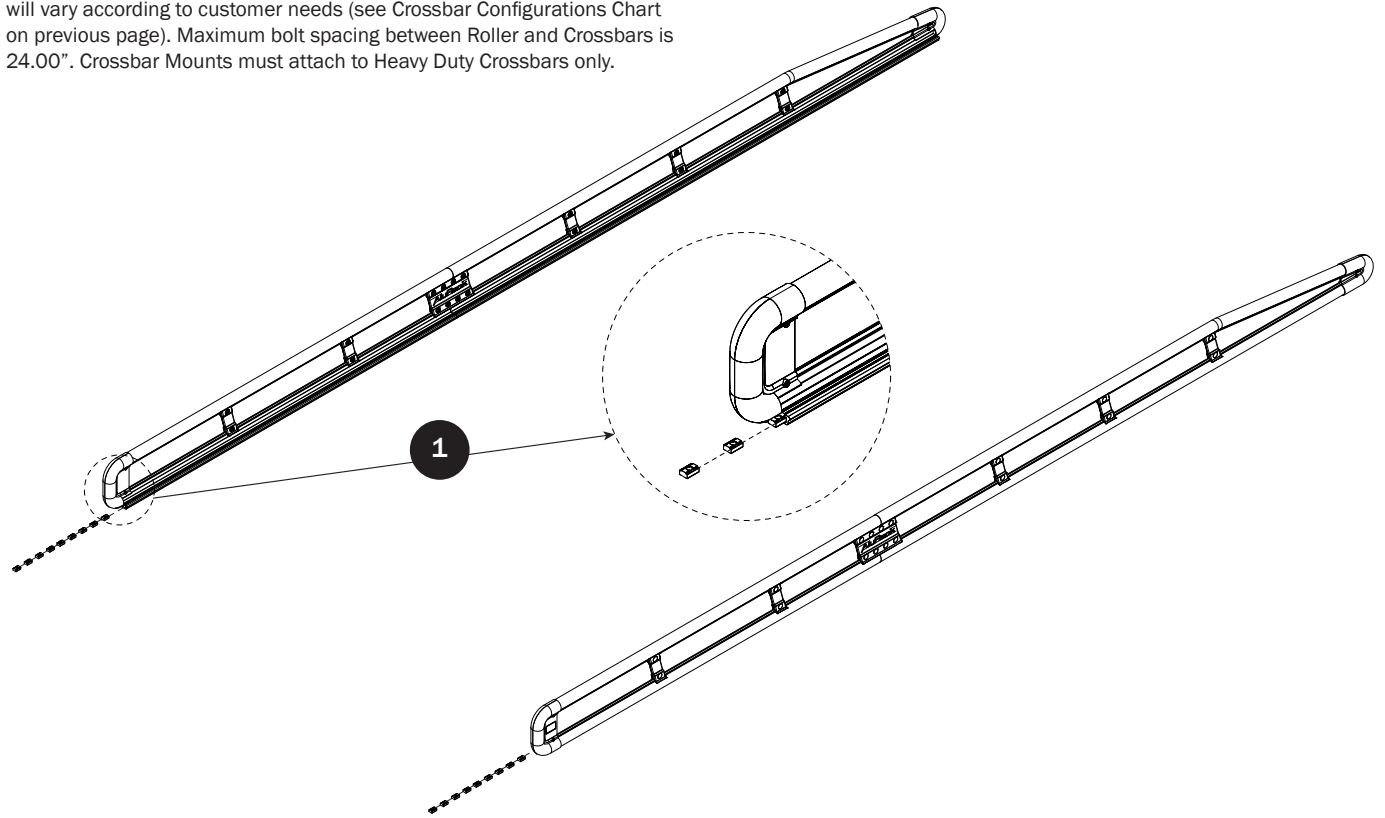
**ROLLER BRACKETS**

- 2** Install Roller Brackets into the rear most Strip Nuts, and align flush against the rear end of the Side Rail as shown. Torque Roller Bracket Bolts to 90 in-lbs.

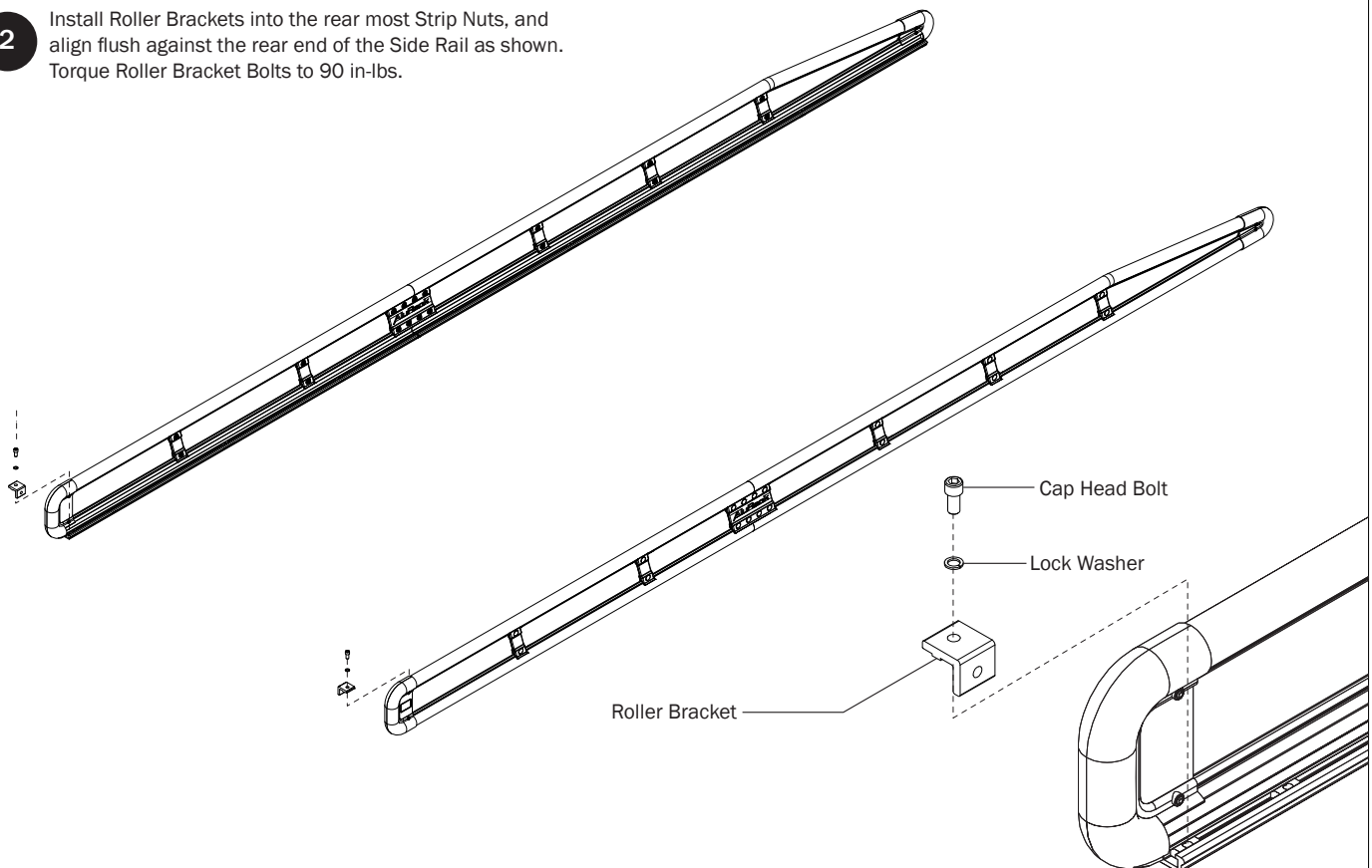

LEFT SIDE RAILS AND CROSSBARS

- 3 Install the Crossbars according to your configuration in the Strip Nuts as shown and torque to 90 in-lbs.

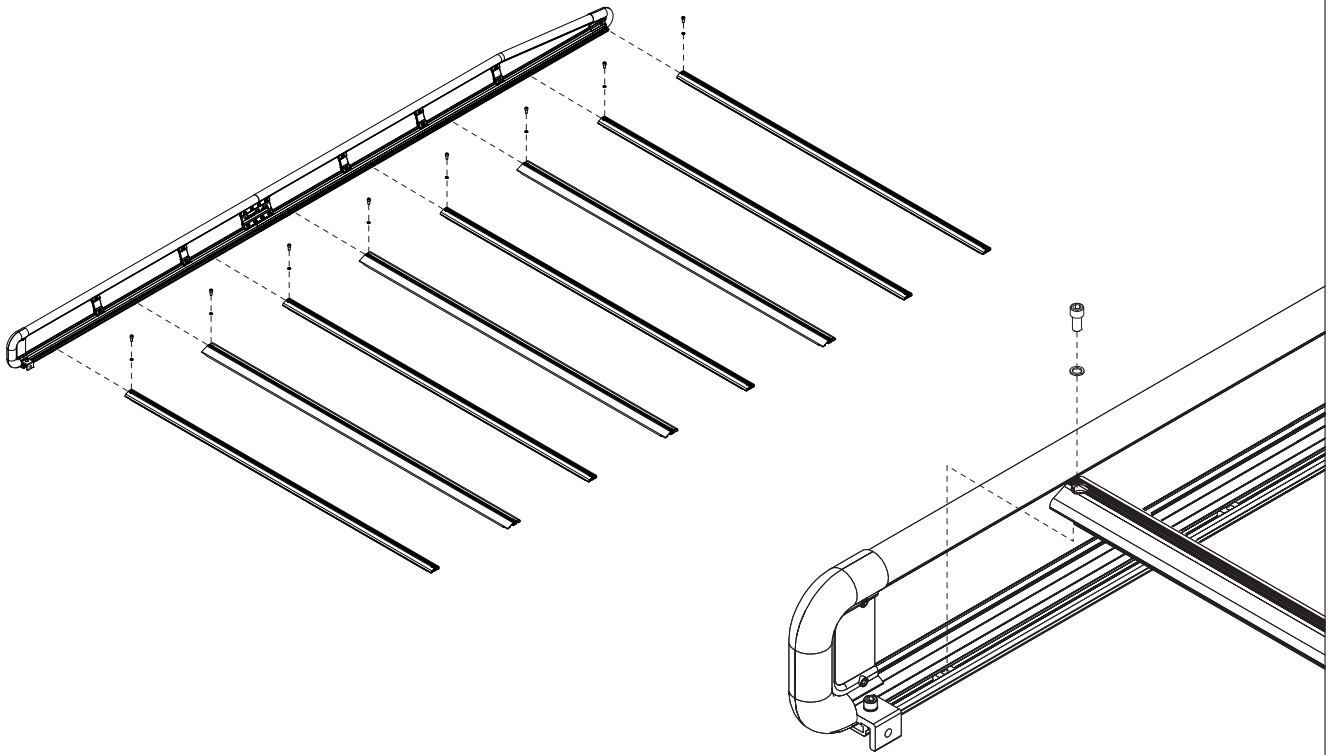

RIGHT SIDE RAILS AND CROSSBARS

- 4 Install the Crossbars according to your configuration in the Strip Nuts as shown and torque to 90 in-lbs.

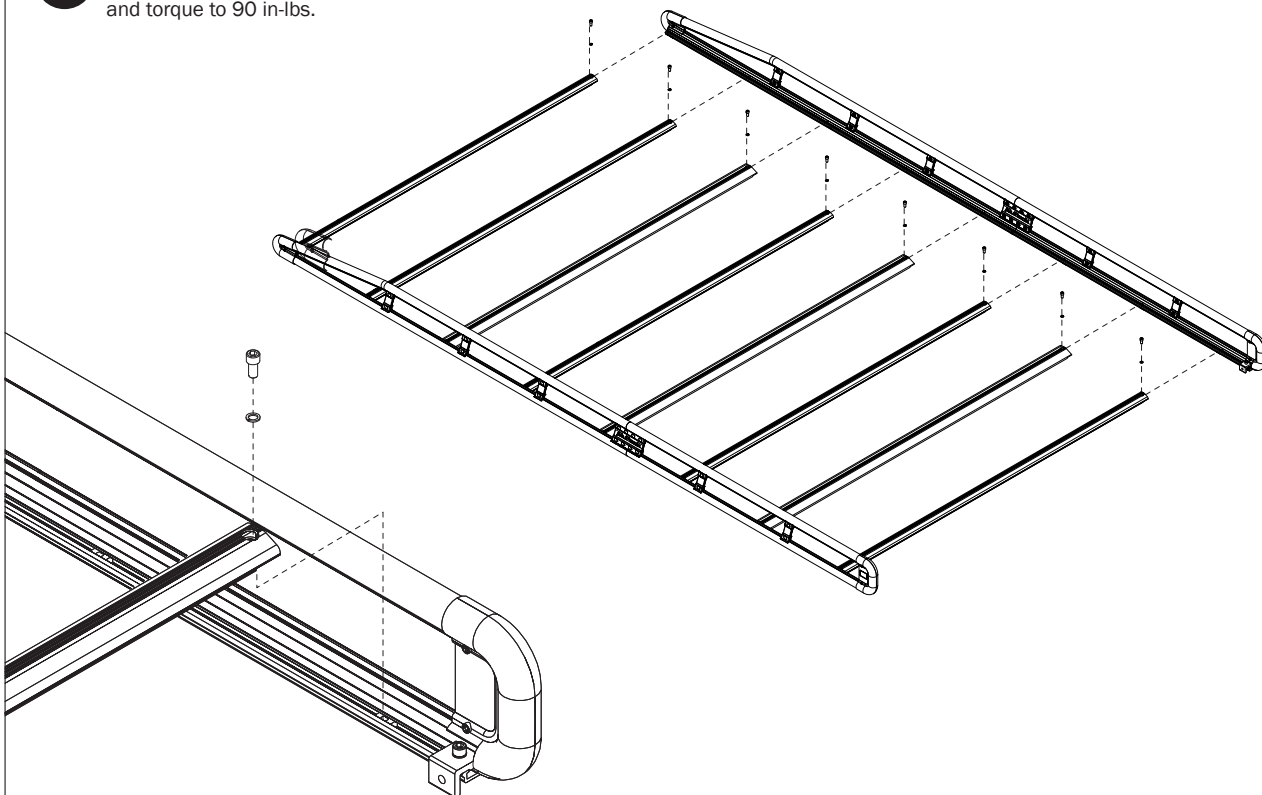

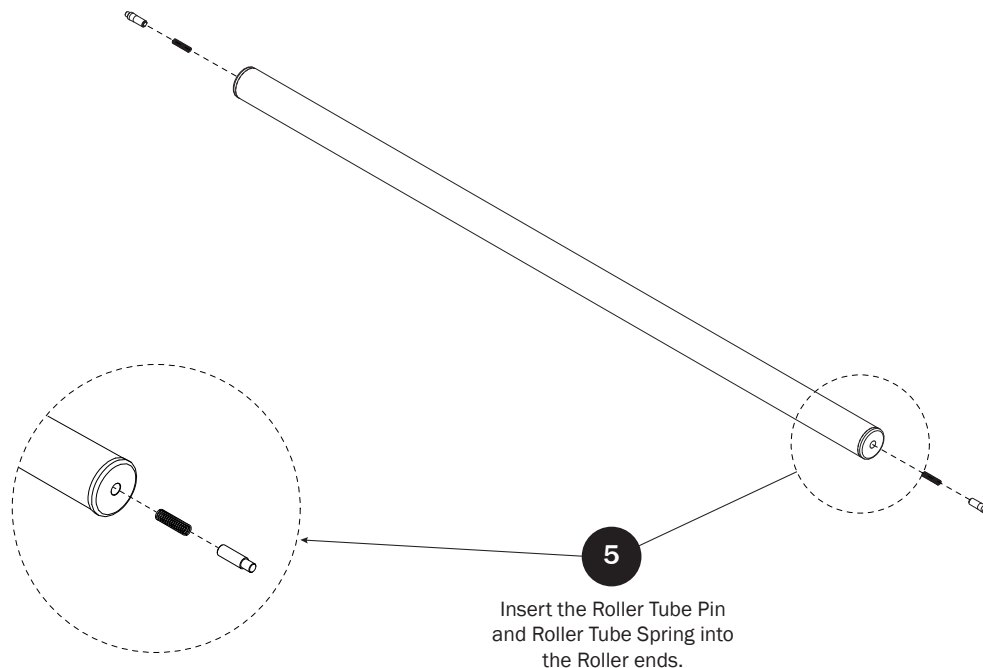
ROLLER ASSEMBLY**ROLLER INSTALLATION**

- 6** Insert the Roller Tube Pin on each side of the Roller Tube into the Brackets as shown.

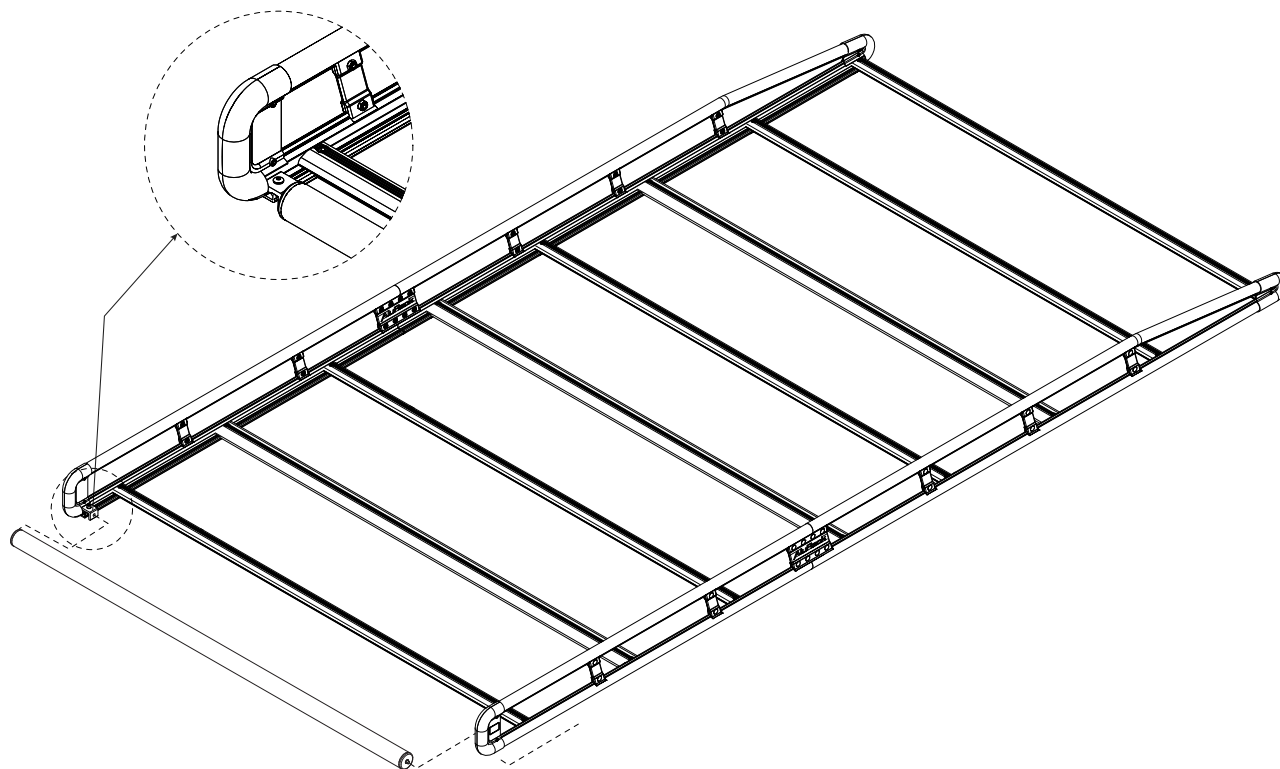

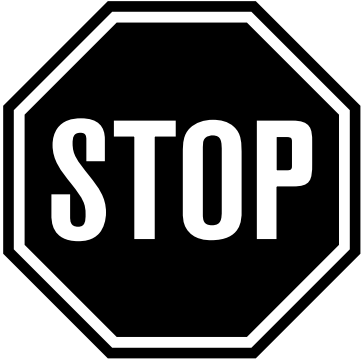

Do not mount the AluRack to an FBM system at this time.

Refer to the respective FBM Assembly Manual(s) included with your chosen rack configuration features.

WARNING: Failure to position the AluRack as shown in your FBM Assembly Manual may result in damage to the ladder rack.

INSTALLER NOTE: To purchase applicable features and accessories, please contact your authorized distributor, or a Prime Design Sales & Service Representative.

