

PRIME DESIGN™

A Safe Fleet Brand

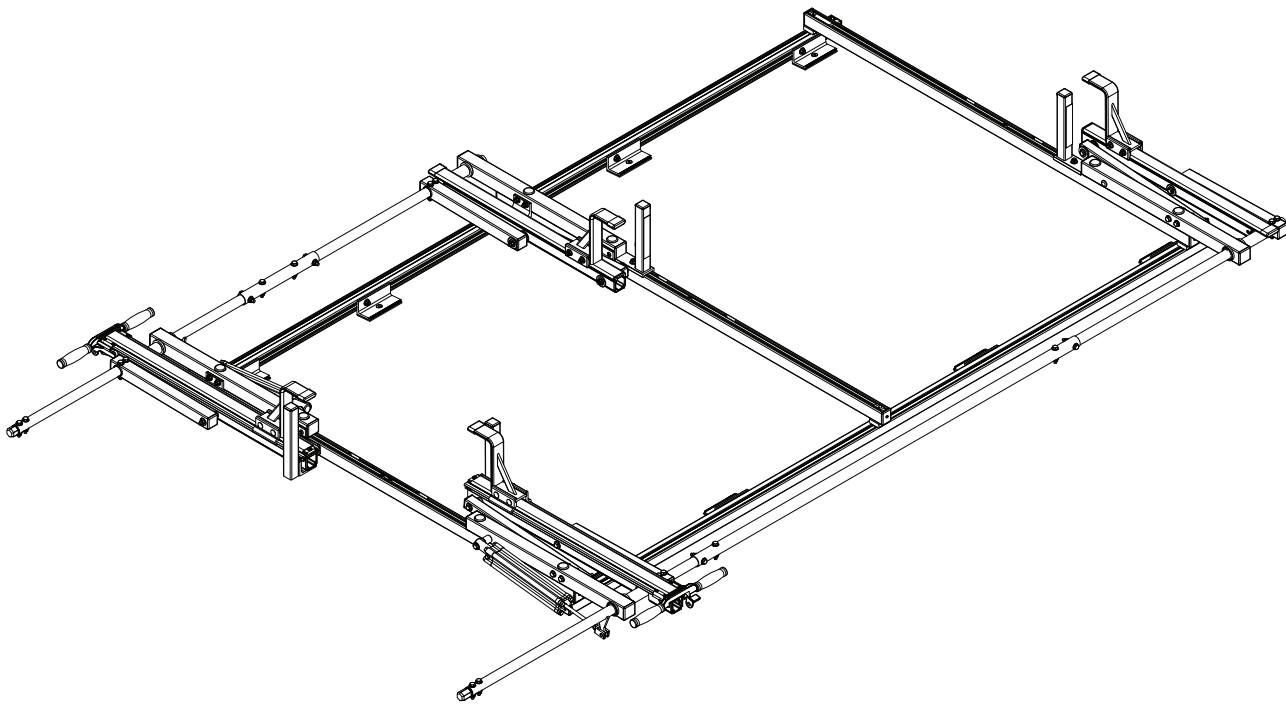

SHIP THROUGH BOX

PRIME DESIGN, A SAFE FLEET BRAND

Address: 580 Opperman Drive, Eagan, MN 55123 • Toll Free: 1.8.PRIME.RACK

Fax: 651-552-1799 • Email: info@primedesign.net • Website: www.primedesign.net

VRR3-FT31G-ST

CONTENTS OVERVIEW

Installer's Note: This fully built ladder rack illustration cross-references with the STB-0001 Ship Thru Box illustration shown below, and the parts list shown on Page 3 of this Manual.

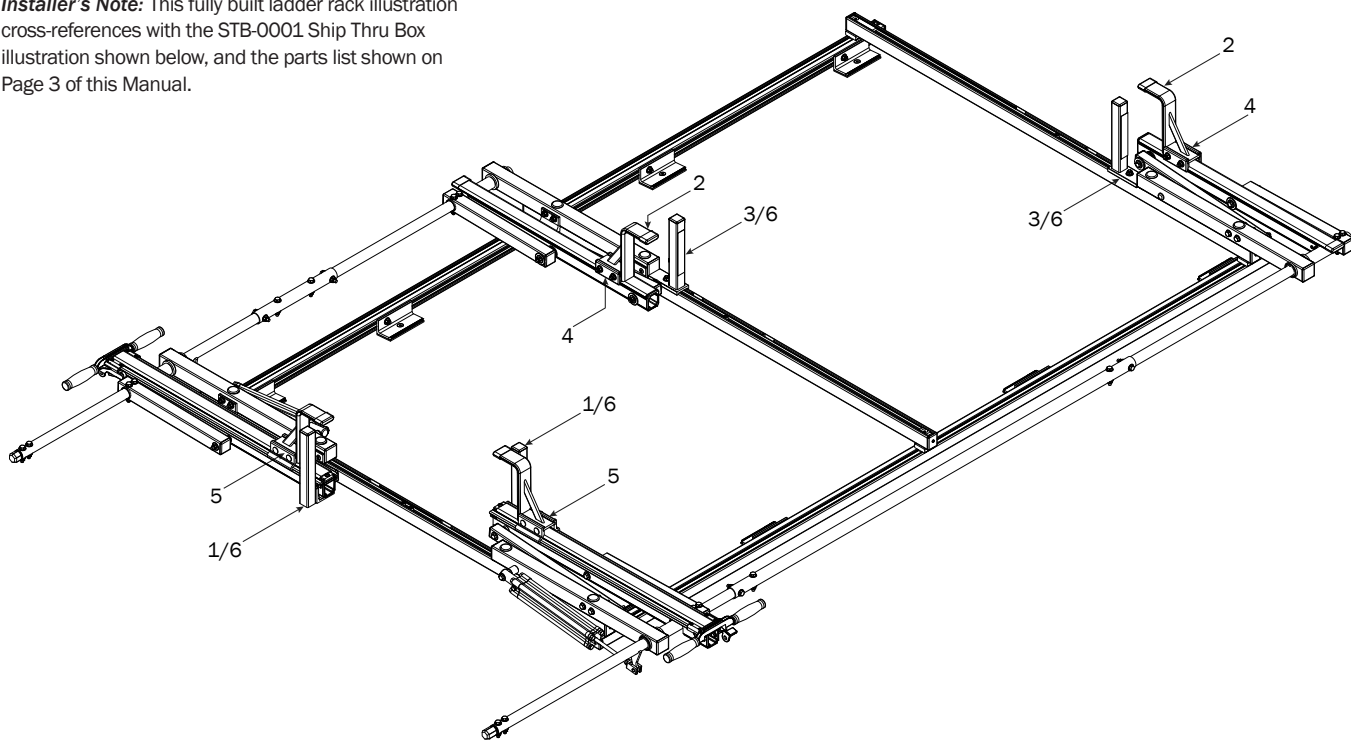

STB-0001 Ship Thru Box

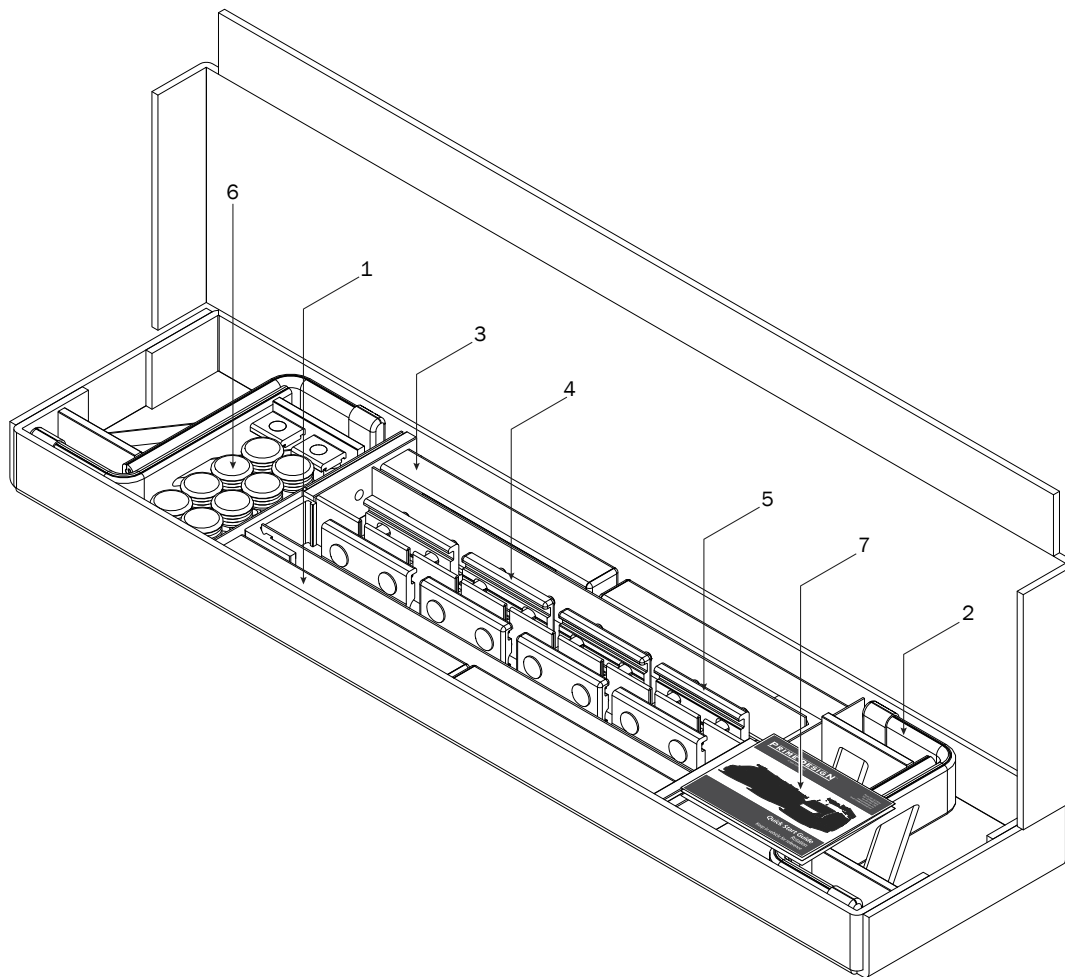

1—L Post Assembly (Qty 2)
Slide, Rear, G2, Sq Cap, Bottom Mount, 9.25"

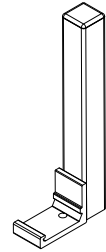

2—Z Post (Qty 4)
Front and Rear, Adjustable, 6.50", Padded

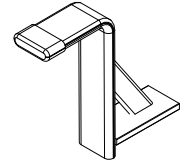

3—L Post Assembly (Qty 2)
Front, Low Profile, Sq Cap, Top Mount, 8.50"

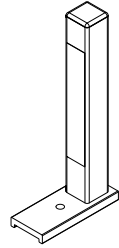

4—Z Post Bracket Assembly (Qty 2)
Front, Adjustable

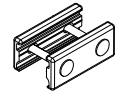

5—Z Post Bracket Assembly (Qty 2)
Rear, Narrow Slide, Adjustable

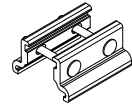

6—HKT-0131..... (Qty 1)
Telescoping Low Profile Hardware

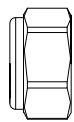

M8 Lock Nut (2X)

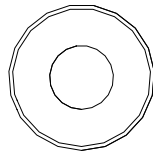

5/16" Flat Washer (4X)

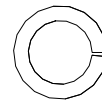

5/16" Lock Washer (2X)

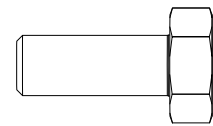

M8 x 20MM (2X)

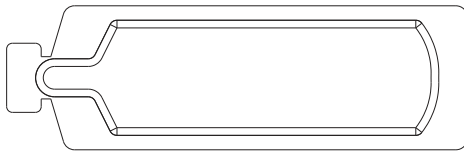

Anti-Seize (1X)

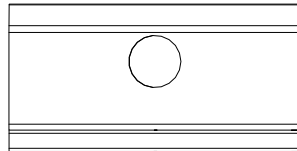

L Post Bracket Clamp (2X)

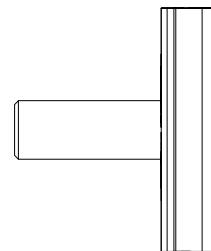

M8 x 25MM T Bolt (2X)

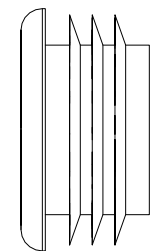

Cap, Black (8X)

7—USQSG-Ergorack..... (Qty 1)
Quick Start Guide (not shown in Overview illustration)

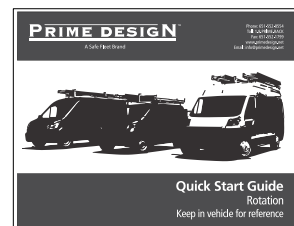

RECOMMENDED ASSEMBLY TOOLS (NOT INCLUDED)

Installer's Note: Do not use power tools to tighten fasteners. Power tools may lead to overtightening and cause damage to the vehicle, or the Ladder Rack hardware. Use only hand tools as shown below.

Torque Wrench (inch-pound), 3/8" drive
Must use for Rotation deployment

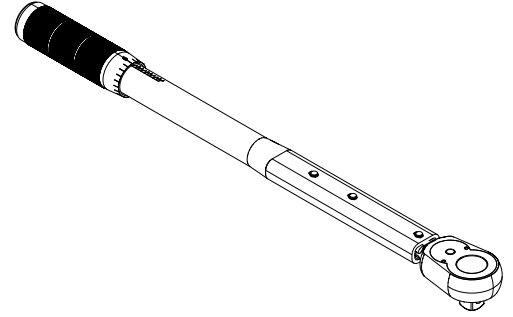

Combination Wrench, 13MM
Can be used for general assembly then followed with Torque Wrench

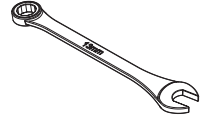

6 pt. 13MM Socket, 3/8" drive
To prevent damaging the aluminum Barrel Nut, do not use a 12 pt. socket



5MM Hex Bit Socket, 3/8" drive



ROTATION DEPLOYMENT

Installer's Note: The Rotations on this Ship Thru rack are factory-mounted inboard of the Crossbar ends. They must be repositioned to the Crossbar's end stops for proper operation and use.

- 0.1** Starting with the Left Hand Rotation, use the 6 point 13MM socket, and loosen the four Barrel Nuts in positions "A" two full turns counterclockwise.

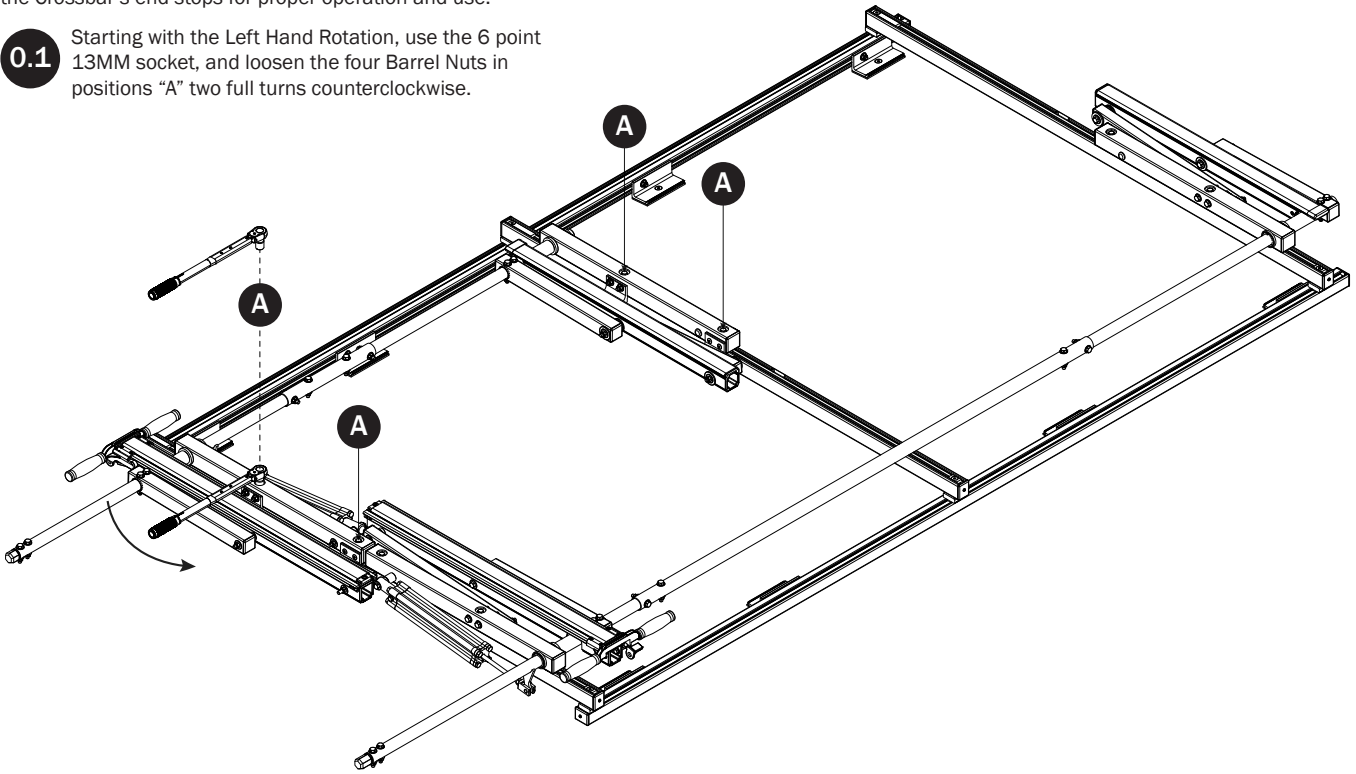

- 0.2** Grasp the Drive Shaft in the shaded areas, then evenly pull the Rotation outward to a hard stop.

- 0.3** Using the 6 point 13MM socket and a torque wrench, tighten the Barrel Nuts loosened during Step 0.1 to 150 in-lbs.

- 0.4** Press black caps into each Barrel Bolt hole marked positions "B" on the Left Hand Rotation Base Assemblies.

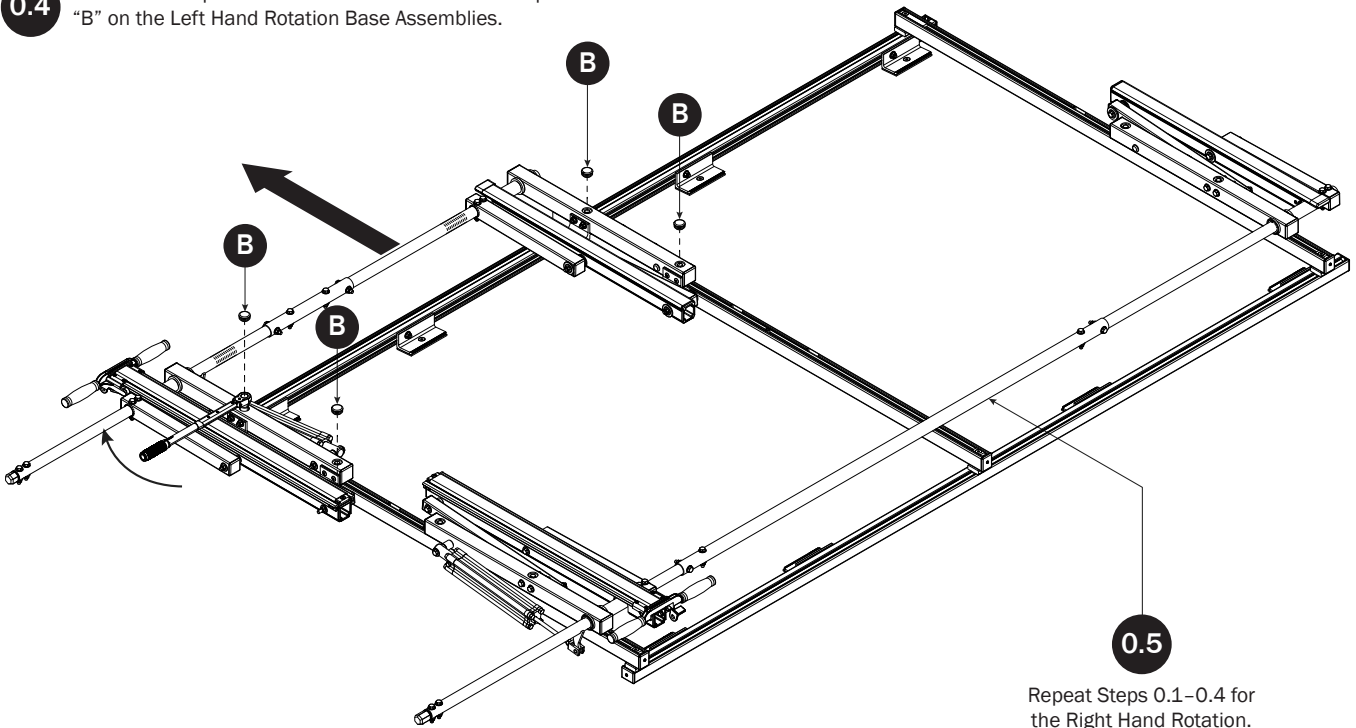

0.5
Repeat Steps 0.1-0.4 for the Right Hand Rotation.

INSTALLATION SEQUENCE

SEE QUICK START GUIDE FOR ADJUSTMENTS

Installer's Note: This rack is labeled for L and Z Post installation. These will be installed with the Rotation open. Begin by removing the Ratcheting Handle from the vehicle's cargo hold, placing it on Drive Shaft's end, then opening the Right Hand Rotation.

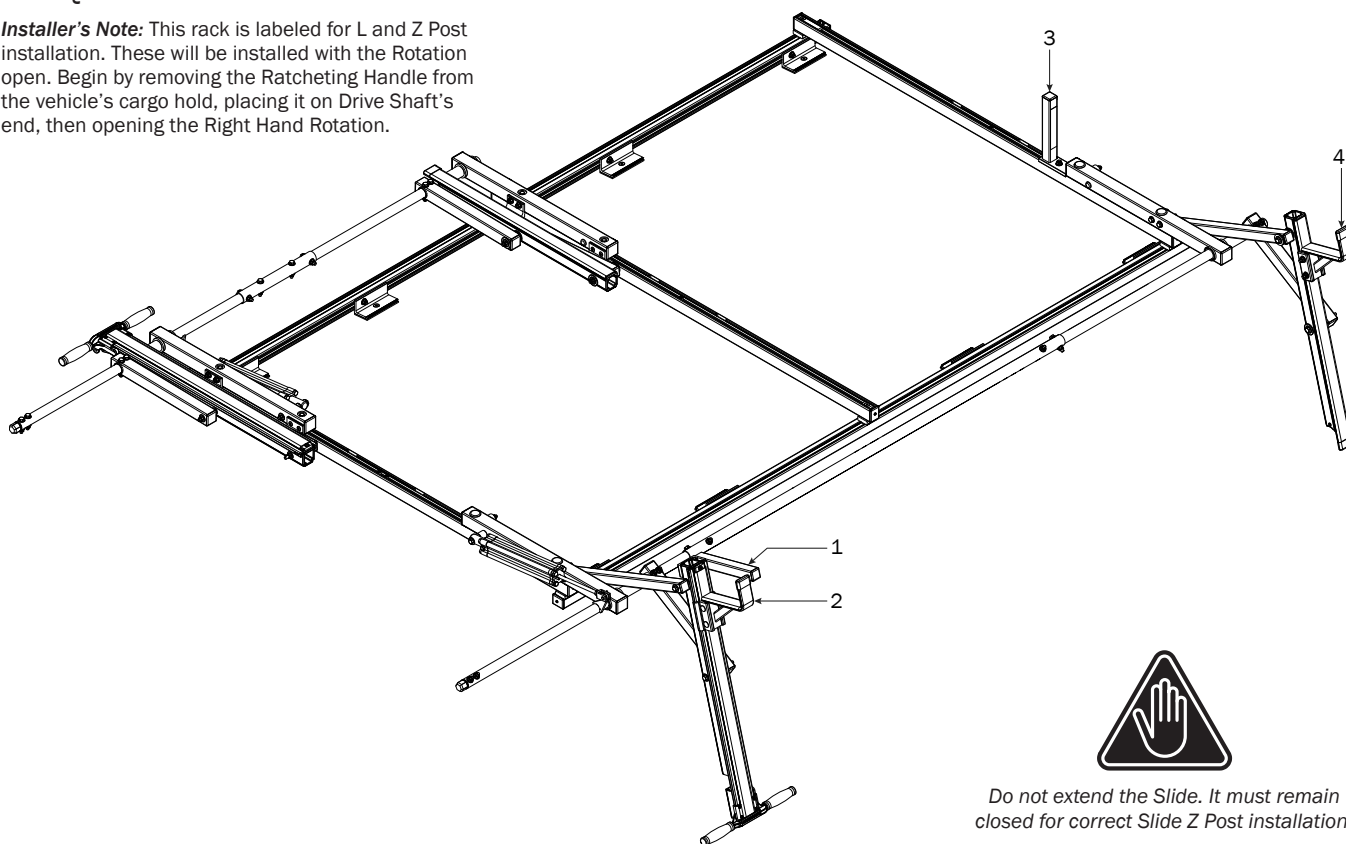

Do not extend the Slide. It must remain closed for correct Slide Z Post installation.

SLIDE L POST

- 1.1** The Rotation Assemblies have a factory attached L and Z Post positioning label. Refer to this label for initial Slide L Post assembly position.

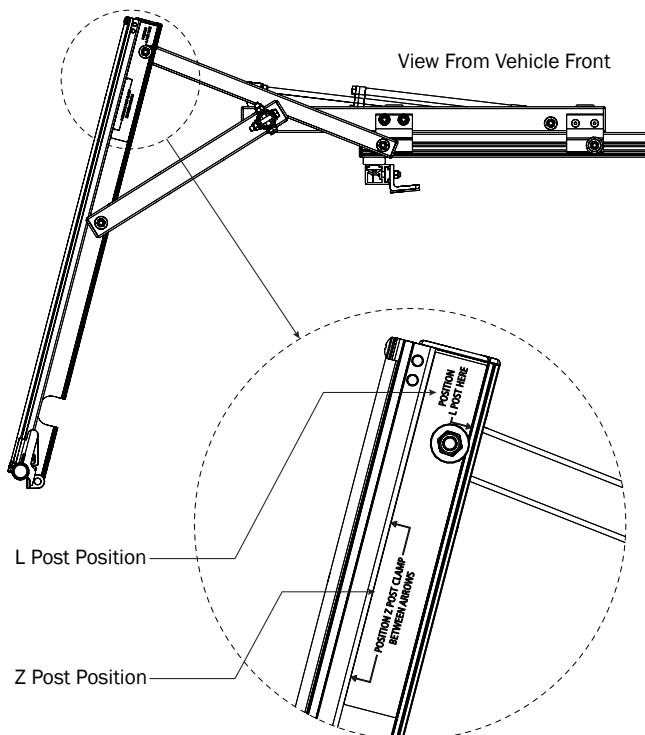

- 1.2** Place the Slide L Post into the bottom groove of the Rear Slide Assembly, ensuring the L Post seats into the Slide's outer bottom groove as seen in Figure C below.

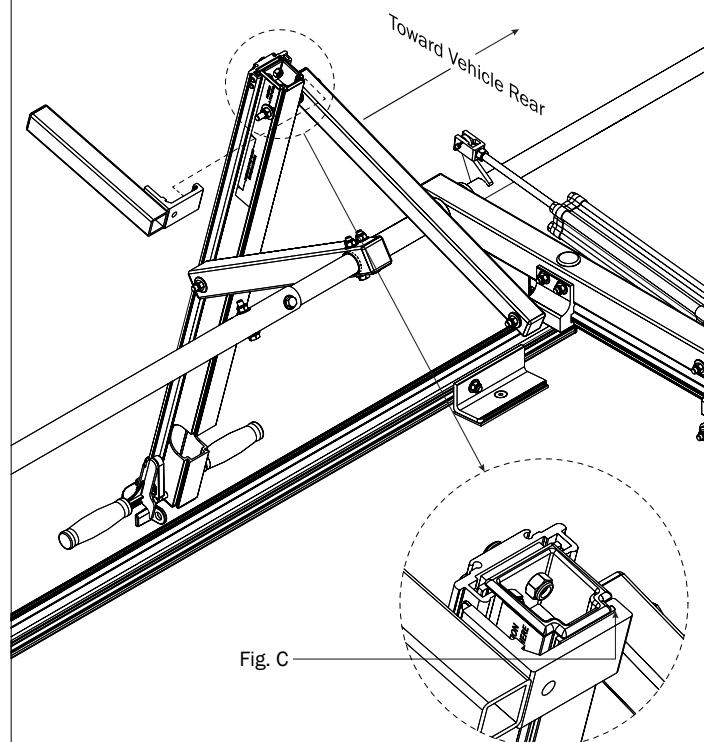

- 1.3** Place the Slide L Post Bracket Clamp into the inner bottom groove of the Slide Assembly, then position it into the L Post Bracket. Assemble the Slide L Post hardware, but do not tighten until Step 1.4

Note: The orientation of the bolt hole faces away from the Slide Upper.

Flat Washer
Lock Washer
M8 x 20MM Hex Bolt

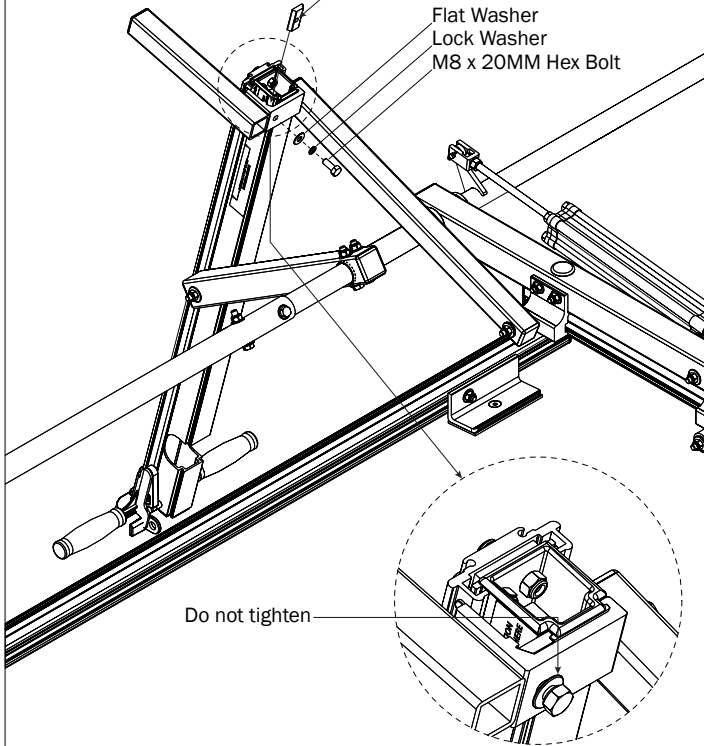

- 1.4** Lightly tighten the Slide L Post bolt, then finalize the alignment of the front edge of the Slide L Post as shown below in Figure D. This must align to the label's L Post positioning arrow shown in the closeup in Step 1.1. Torque the L Post bolt to 90 in-lbs.

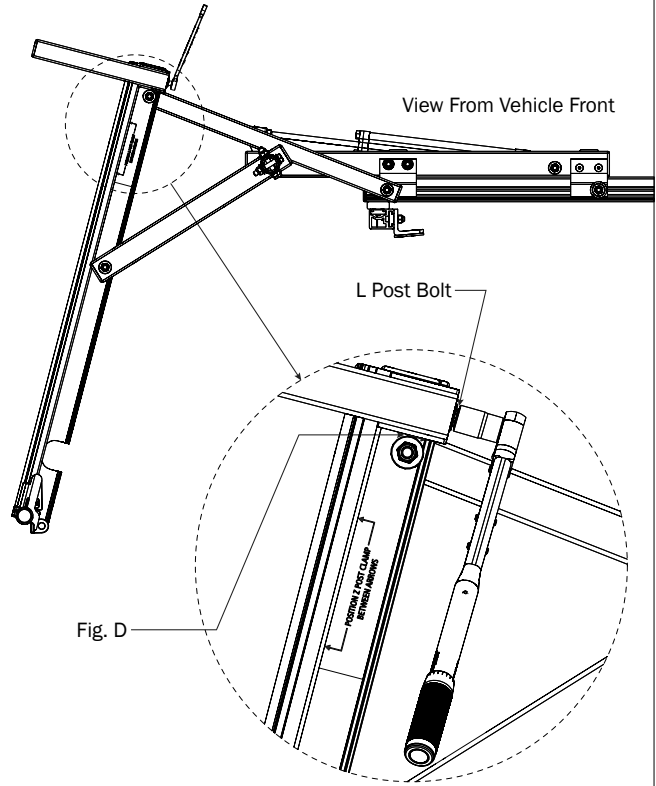

SLIDE Z POST

- 2.1** Place the Slide Z Post Clamp onto the top of the Slide Assembly, ensuring the Z Post Clamp seats into the Slide Upper lip as seen in Figure E below.

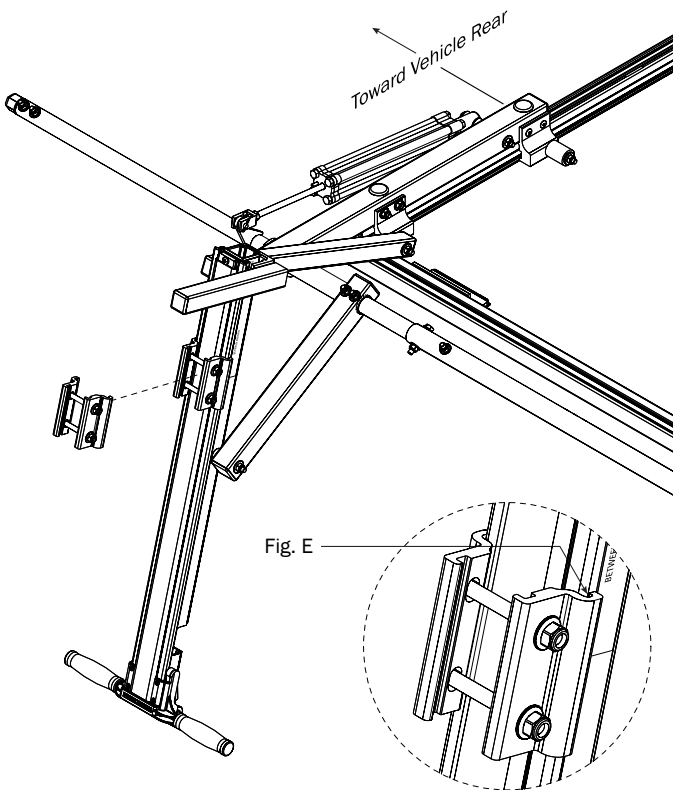

- 2.2** Place the Z Post into the Mounting Clamp Assembly ensuring the Slide Z Post seats into the Clamp's top groove as seen in Figure F below. Do not tighten until of Step 2.4

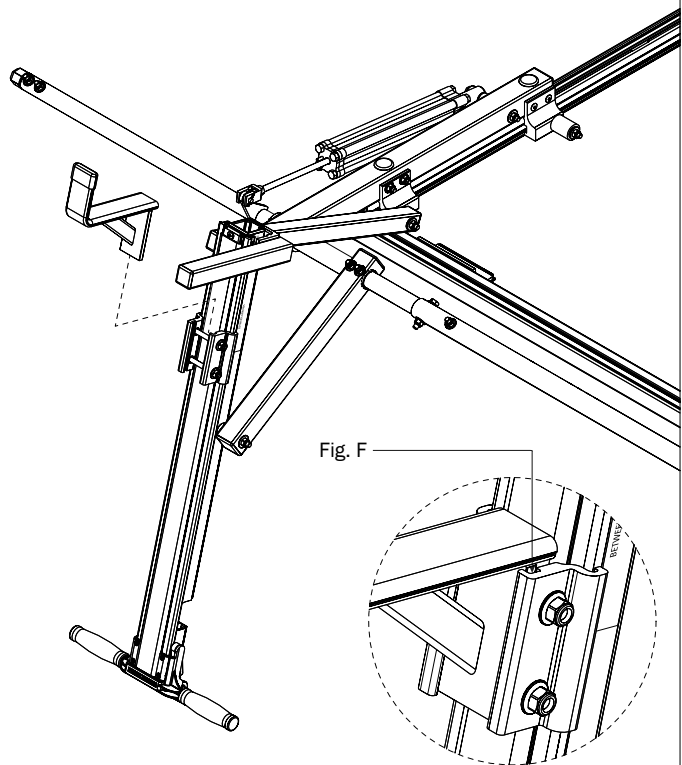

2.3 Lightly tighten the Slide Z Post nuts, then finalize the alignment of the front edge of the Slide Z Post to the arrow as shown below in Figure G.

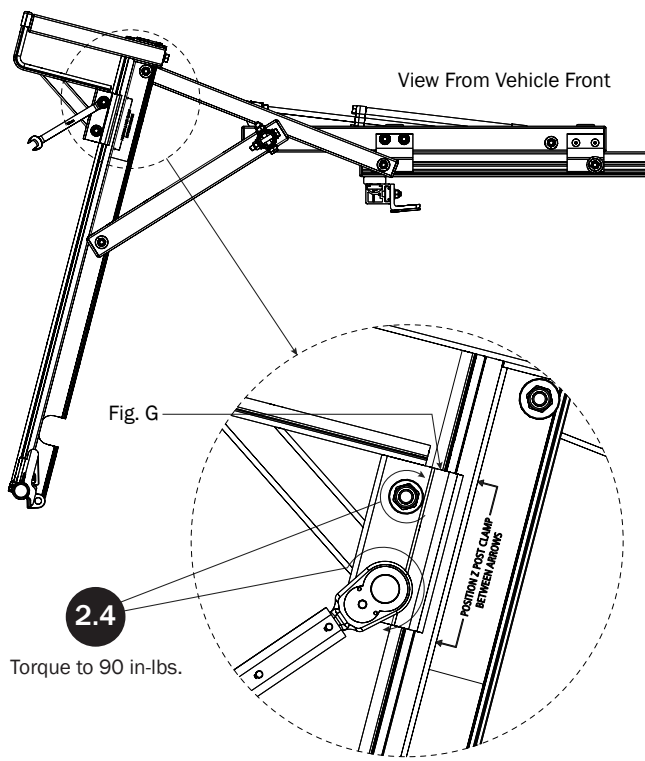

FRONT L POST

3.1 Place the T Bolt into the notched portion of the Front Crossbar.

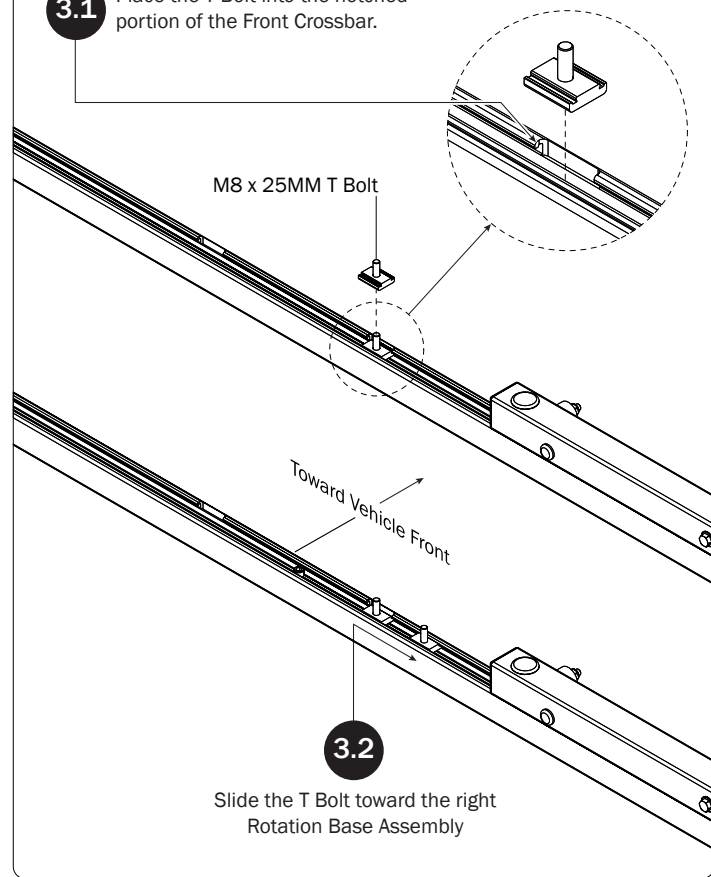

3.3 Assemble the Front L Post onto the Crossbar and T Bolt using the hardware shown below. Do not tighten until Step 3.5.

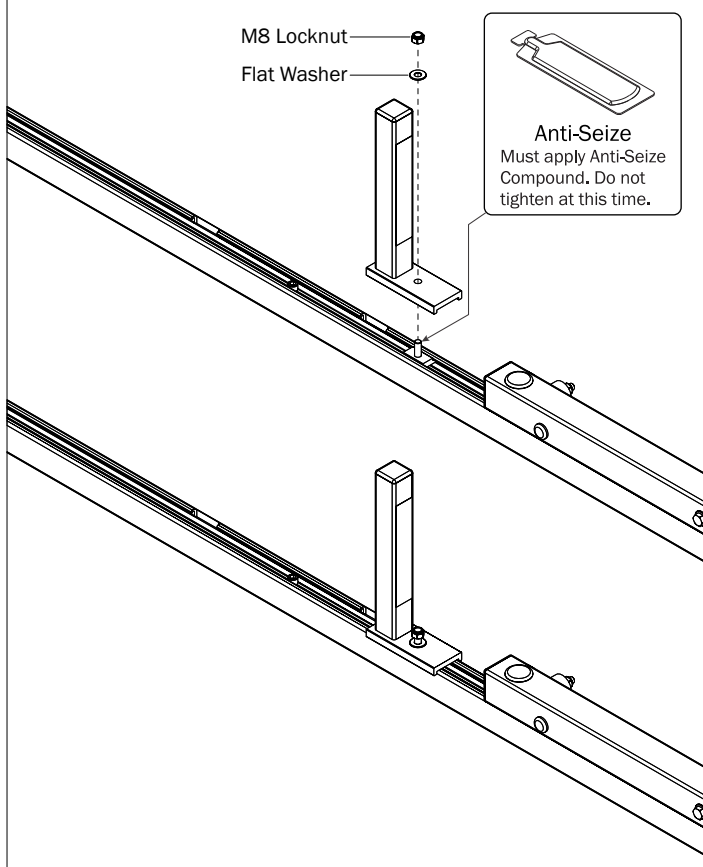

3.4 Slide the Front L Post outward until it fully contacts the Rotation Base Assembly.

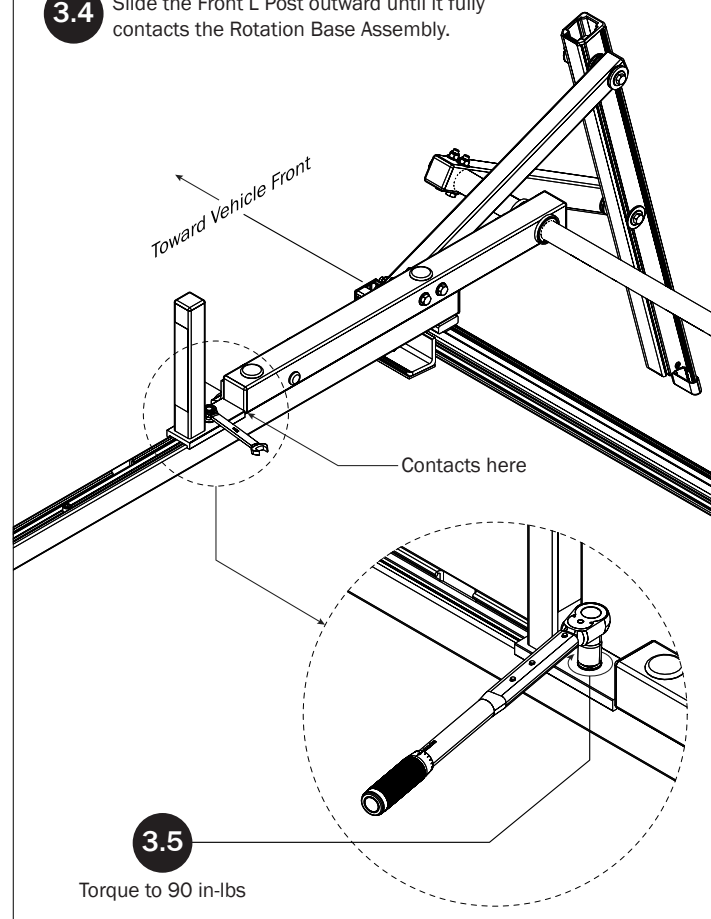

FRONT Z POST

- 4.1** Place the Front Z Post Clamp onto the top of the Front Rotation Assembly, ensuring the Z Post Clamp seats into the top groove as seen in Figure H below.

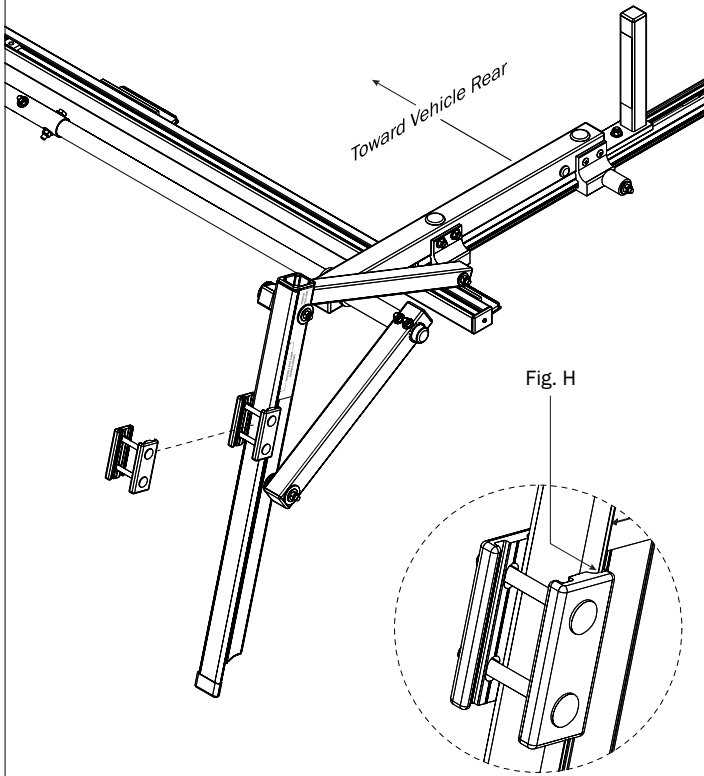

- 4.2** Repeat Steps 2.2–2.4 to complete the assembly of the Front Rotation Z Post.

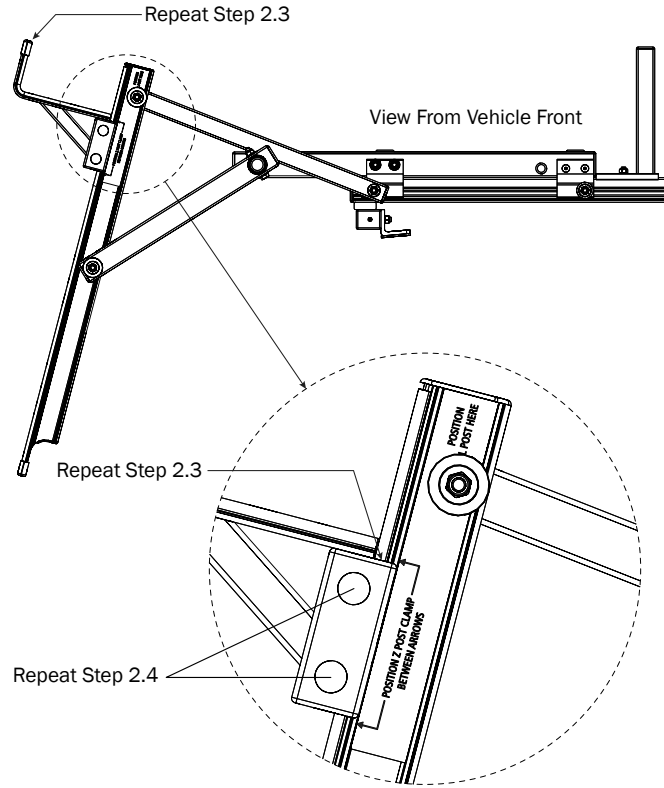

- 4.3** Close the right hand Slide Rotation then proceed to the L and Z Post installation on the left hand Rotation.

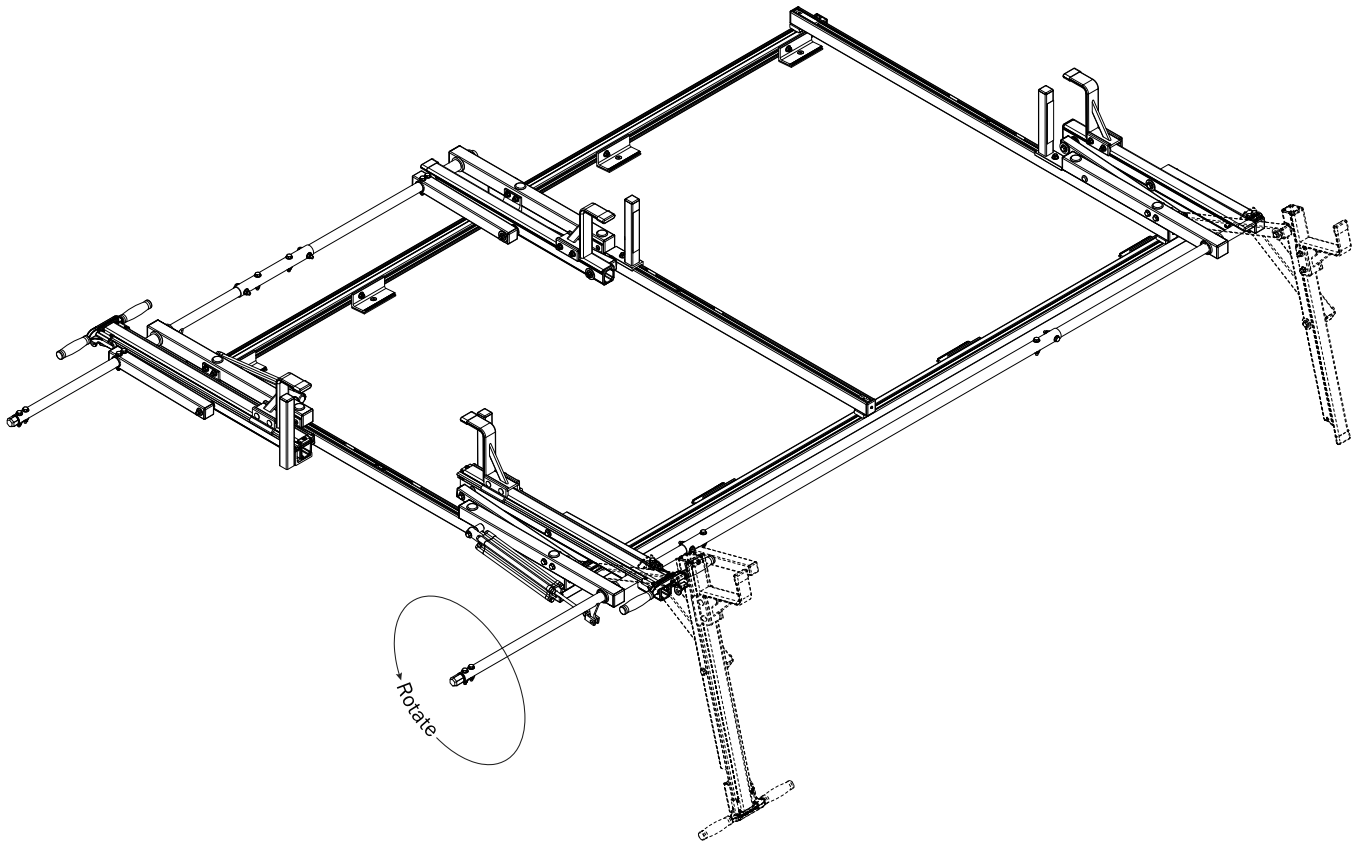

LEFT SIDE INSTALLATION SEQUENCE

Installer's Note: Open the Left Hand Rotation to install the L and Z Posts.

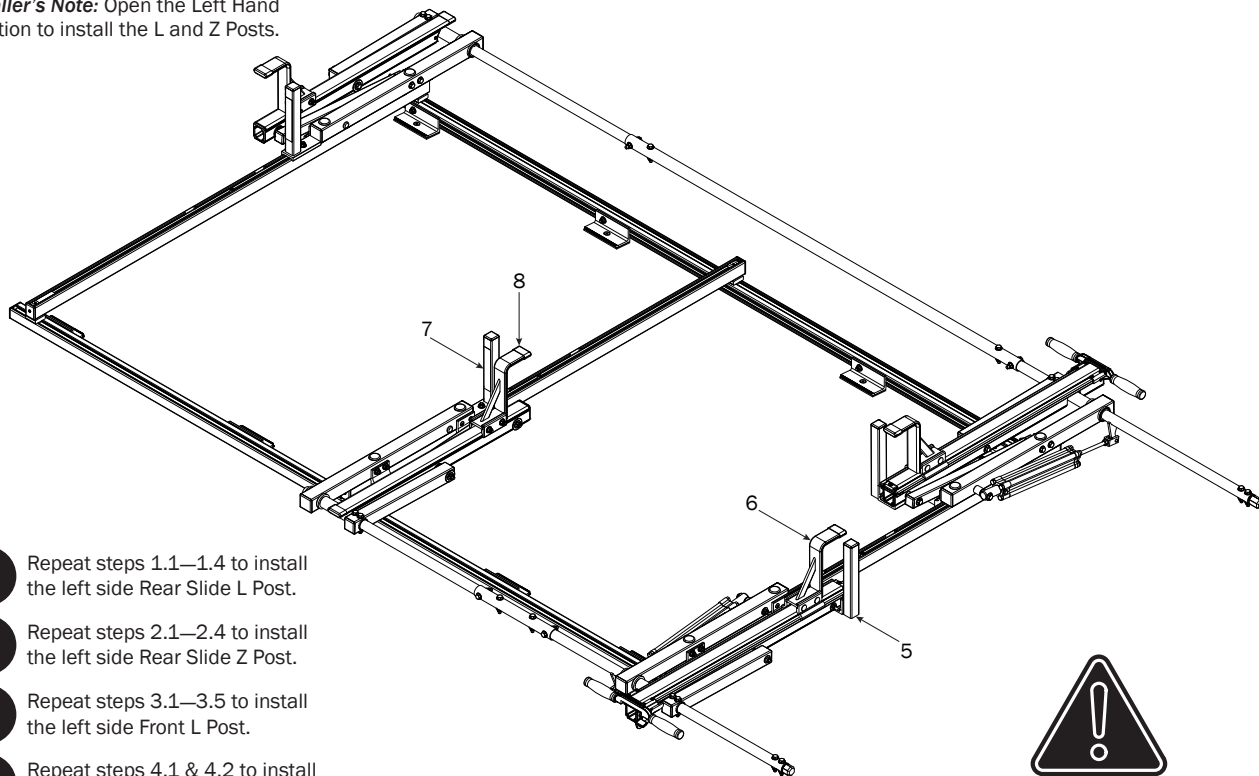

- 5 Repeat steps 1.1—1.4 to install the left side Rear Slide L Post.
- 6 Repeat steps 2.1—2.4 to install the left side Rear Slide Z Post.
- 7 Repeat steps 3.1—3.5 to install the left side Front L Post.
- 8 Repeat steps 4.1 & 4.2 to install the left side Front Z Post.
- 9 Close the Left Hand Rotation.



Replace the Ratcheting Handle into the cargo hold of the vehicle immediately upon completion of this rack build.

QUICK START GUIDE

- 10 Remove the Quick Start Guide found inside the Ship Thru Box, and place it into the vehicle's glove box for End User ladder setup and adjustment.

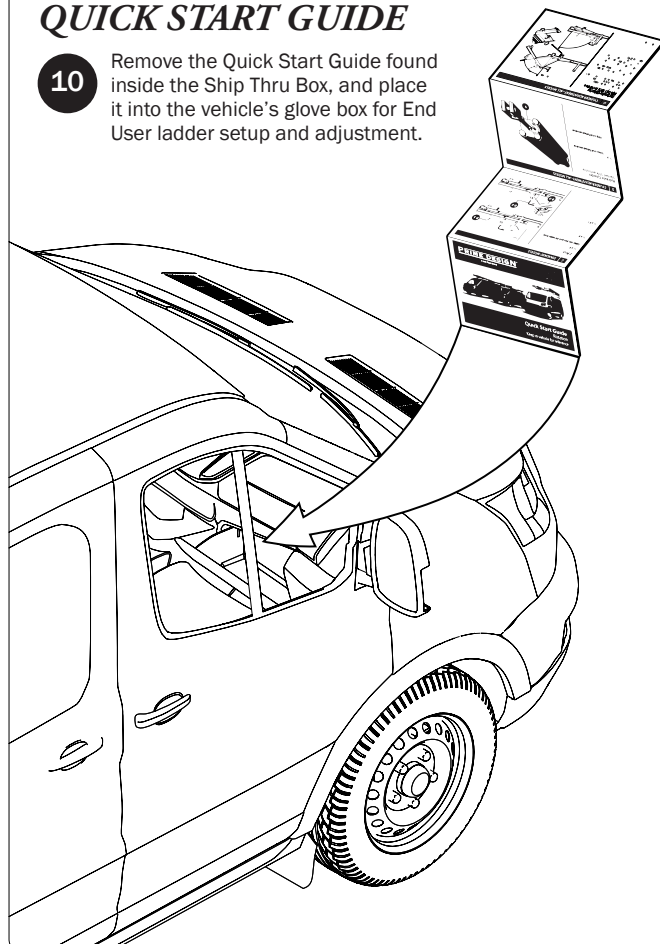

Page Intentionally Left Blank

