

VRR3-FT-M

ErgoRack, Ford Transit Low Roof

Three Crossbars, Powder Coat Finish
Rack Weight (empty): 142 lbs

*Callouts in this Configuration Overview indicate full module assemblies only.

For details on individual parts, please refer to the linked Module Overviews below.

- A: [FEA-0016 Rotation Driveshaft Feature](#)
- B: [FBM-1017-BLK Mounting System](#)
- C: [FEA-0002 Rotation Assembly \(x2\)](#)
- D: [CBR-0005 Crossbar Assembly](#)
- E: [CBR-0006 Crossbar Assembly](#)
- F: [FEA-0015 Rotation Driveshaft Feature](#)

[Modular Assembly Manuals](#)

ErgoRack Van—Load specifications:

Check vehicle manufacturer recommendations for roof capacity weight limits.

CROSSBAR SPACING	STEP LADDER	EXT. LADDER
4 ft Spacing	6 – 8 ft.	16 – 20 ft.
5 ft Spacing	8 – 10 ft.	16 – 24 ft.
6 ft Spacing	8 – 12 ft. [†]	16 – 28 ft.
7 ft Spacing	10 – 12 ft. [†]	20 – 32 ft.
8 ft Spacing	10 – 12 ft. [†]	20 – 36 ft.

[†]Rotation Configurations: 12 ft. step ladders require an extended upper add-on component.

*Example shown with 130" Wheelbase Configuration

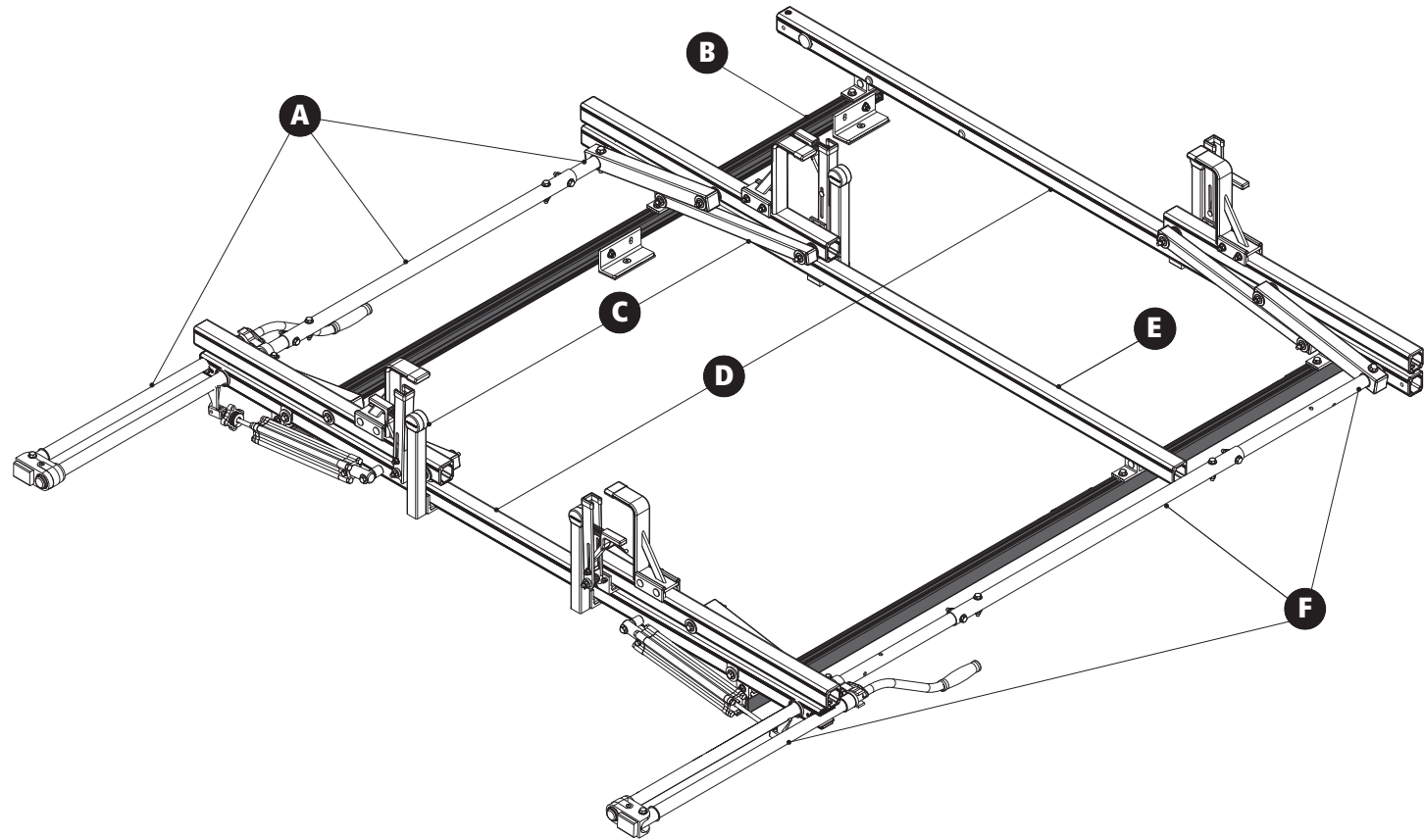

VRR3-FT-M

ErgoRack, Ford Transit Low Roof

Approximate dimensions as shown:

All Wheelbases

A: Rack Width	78"
B: Rack Height	16"
C: Rear Crossbar Offset (Left).....	10.25"
D: Mount Bolt Spacing L/R.....	54"

130" Wheelbase

E: Crossbar Spacing (rear to center)	4'
F: Crossbar Spacing (center to front)	2'
G: Total Crossbar Spacing	6'
H: Rack Length.....	100"

148" Wheelbase

I: Crossbar Spacing (rear to center)	4'
J: Crossbar Spacing (center to front).....	*2'-4'
K: Total Crossbar Spacing	*6-8'
L: Rack Length	121"

*5' Connecting Bars (sold separately) are required for spacings that exceed 6'—contact Sales & Service.

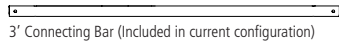

3' Connecting Bar (Included in current configuration)

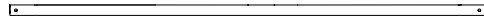

5' Connecting Bar (Sold separately)

Compatible Accessories Available

(Sold Separately)

5' Rotation Connecting Bar	FEA-0022
Rear Access Ladder.....	AAL Series
8'-12' Conduit Carriers.....	CON Series
WorkPro LED Lighting.....	LED Series
Systems and Safety Components	RVS Series
Safety monitoring.....	DS2 Series

USOV-VRR3FTM-US01 Rev-A 0919

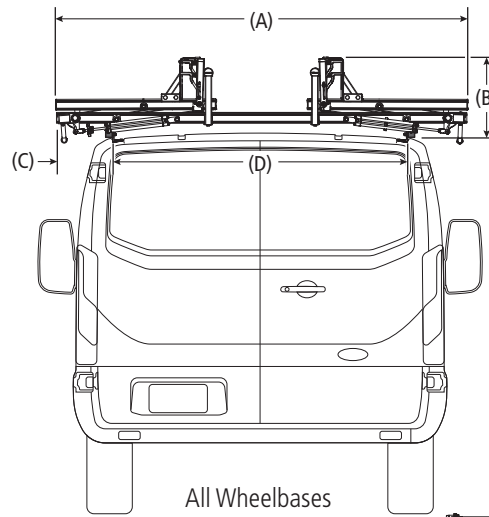

All Wheelbases

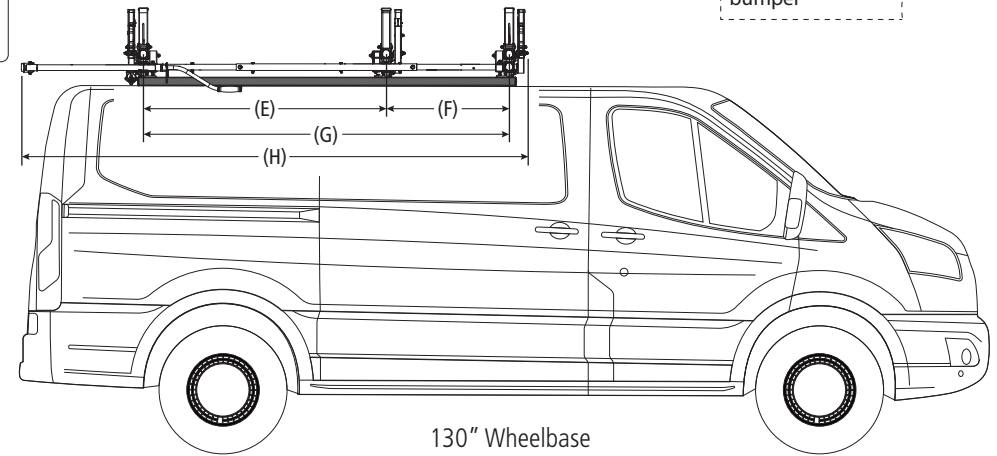

130" Wheelbase

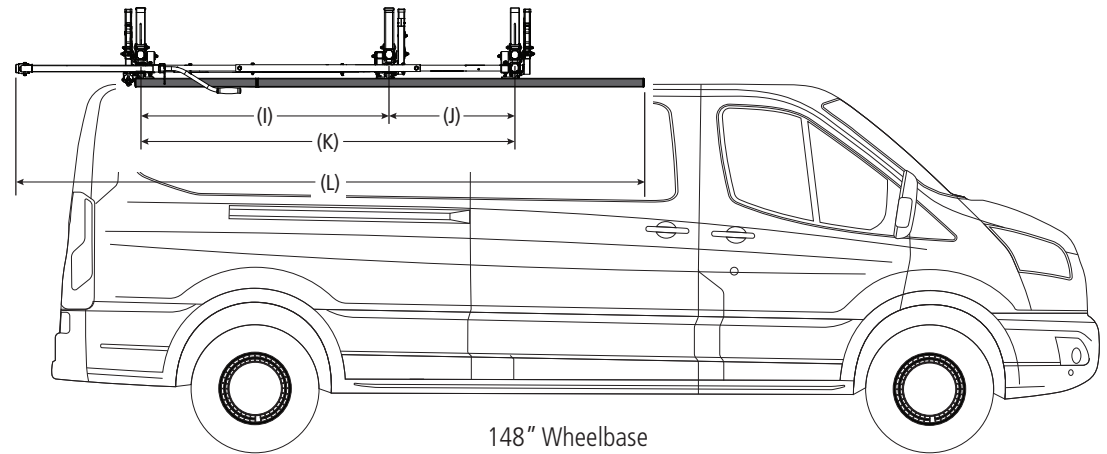

148" Wheelbase

Rear Drive Shaft Offset: 24"

Note: The end of the driveshaft must not extend beyond the vehicle bumper

