

# PRIME DESIGN™

A Safe Fleet Brand

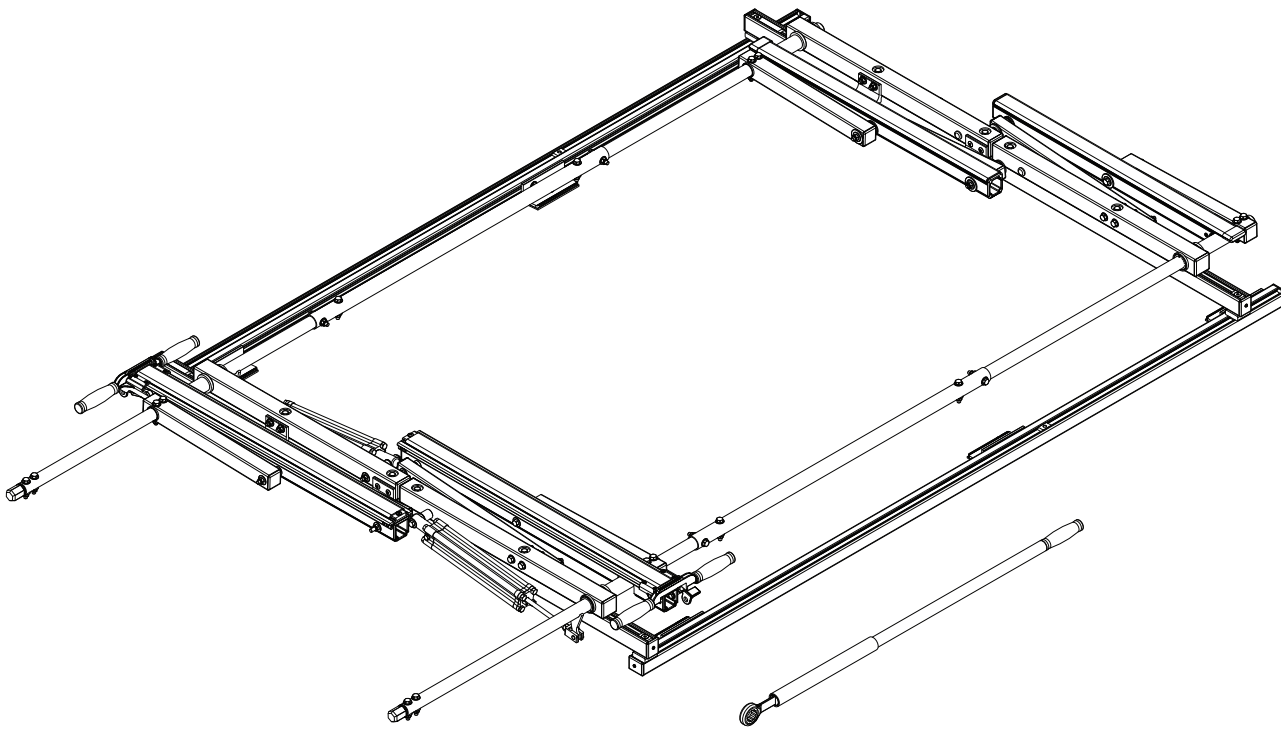

## *SHIP THROUGH BASE & PALLETIZED ROTATION ASSEMBLY*

PRIME DESIGN, A SAFE FLEET BRAND

Address: 580 Opperman Drive, Eagan, MN 55123 • Toll Free: 1.8.PRIME.RACK  
Fax: 651-552-1799 • Email: [info@primedesign.net](mailto:info@primedesign.net) • Website: [www.primedesign.net](http://www.primedesign.net)

# VRR-FT21G-ST

CONTENTS OVERVIEW

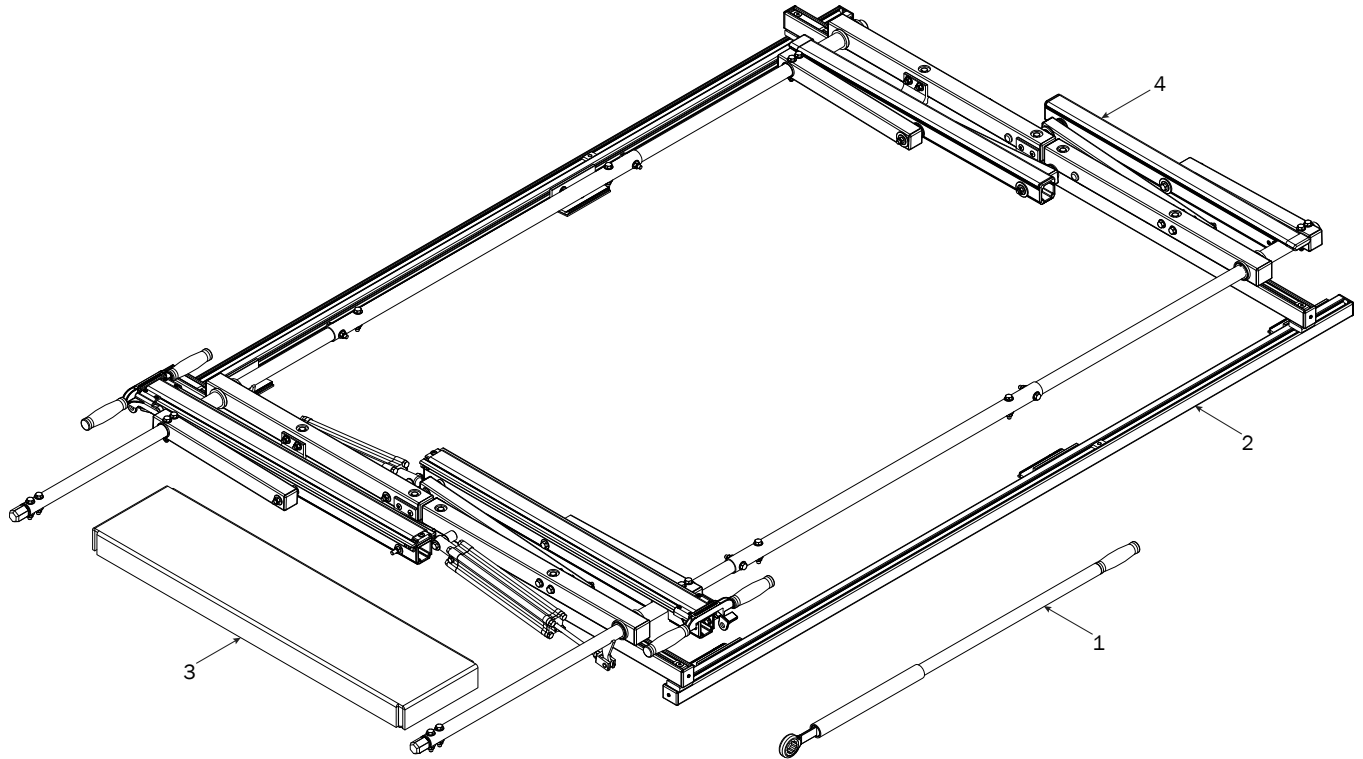

1—ELR-8366..... (Qty 1)  
41" Ratcheting Handle (Stow into back of vehicle)

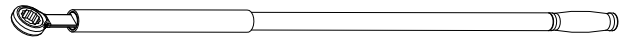

2—FBM-0098 ..... (Qty 1)  
78"L, Pre-Assembled Channels w/Mounting Brackets and Hardware (may include extra hardware)



78" Channels, Pre-assembled (2X)

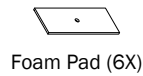

Foam Pad (6X)

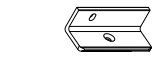

Mounting Bracket (6X)

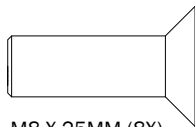

M8 X 25MM (8X)

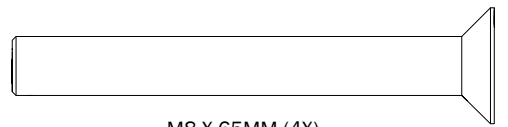

M8 X 65MM (4X)

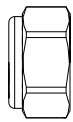

M8 Lock Nut (8X)

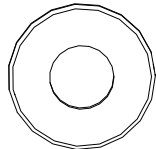

5/16" Flat Washer (8X)

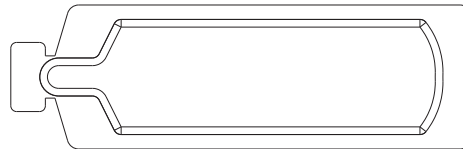

Anti-Seize (1X)

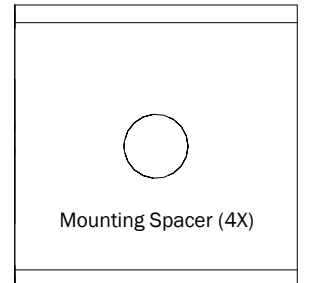

Mounting Spacer (4X)

3—STB-0001 SHIP THRU BOX ..... (Qty 1)  
Do not open. Stow into back of vehicle.

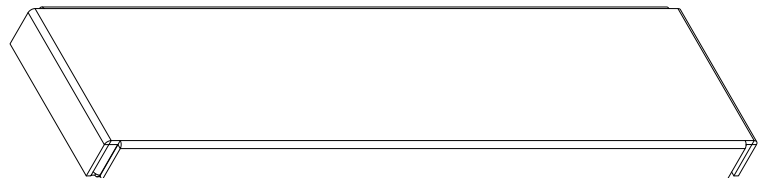

4-VRR-9001 ..... (Qty 1)  
 Factory Assembled Rotation Assembly

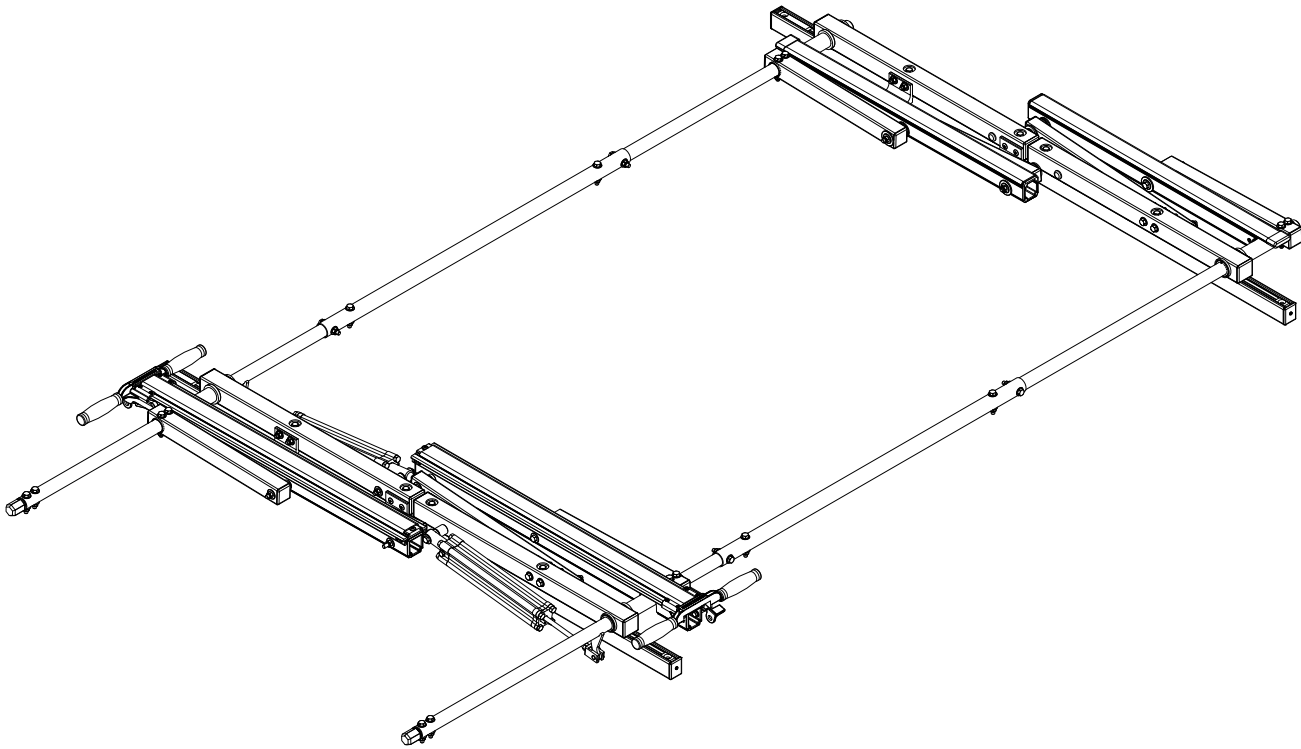

**RECOMMENDED ASSEMBLY TOOLS (NOT INCLUDED)**

*Installer's Note:* Do not use power tools to tighten fasteners. Power tools may lead to overtightening and cause damage to the vehicle, or the Ladder Rack hardware. Use only hand tools as shown below.

Torque Wrench (inch-pound), 3/8" drive

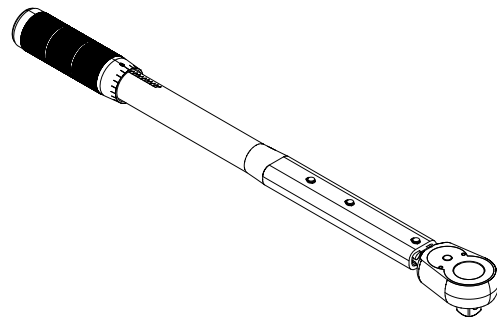

Combination Wrench, 13MM  
 Can be used for general assembly then followed with Torque Wrench



6 pt. 13MM Socket, 3/8" drive



5MM Hex Bit Socket, 3/8" drive



8MM x 1.25 Chasing/Thread Cleaning Tap



**LOW ROOF MEDIUM WHEEL BASE (130.00")**  
**FBM ASSEMBLY SEQUENCE**



Prior to assembling the Channels and hardware, the OEM roof holes must be chased using an M8 x 1.25 Chasing or Thread Cleaning tap and fluid. Doing so will ensure accurate torque is achieved.

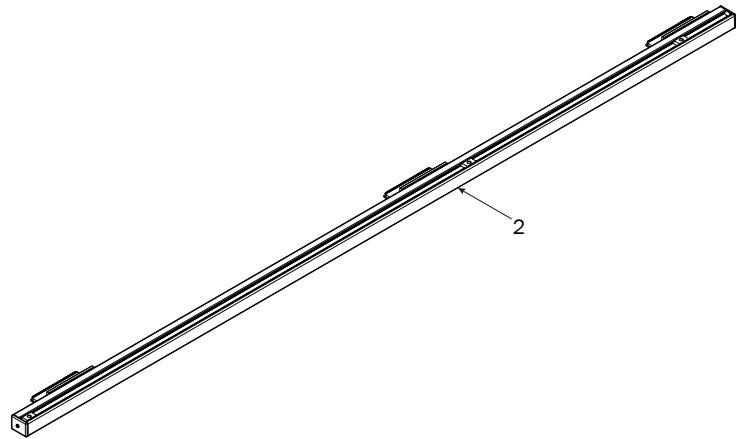
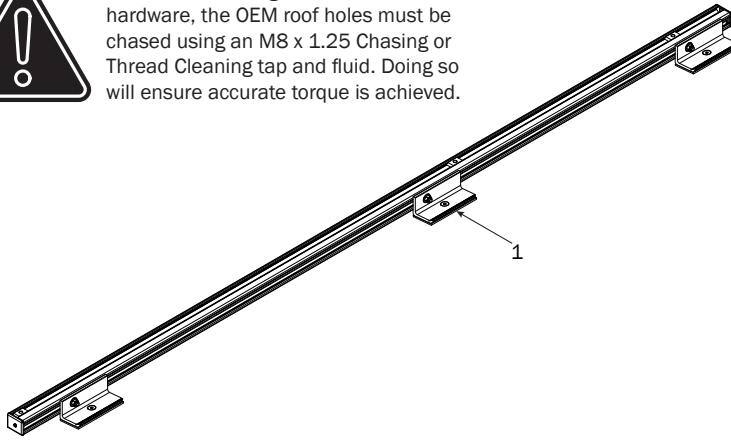

**MOUNTING BRACKETS**

**1** Apply Anti-Seize to all M8 x 25MM Flat Head Screws and install the Channel Mounting Brackets with Foam Pads onto the vehicle's roof mounting holes. Do not tighten screws until Step 2.3

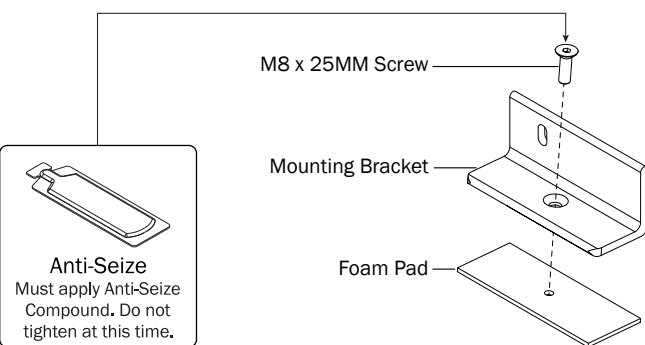
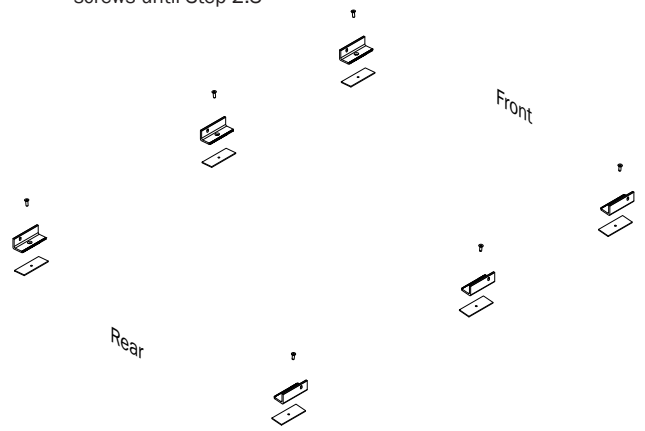

**Anti-Seize**  
Must apply Anti-Seize Compound. Do not tighten at this time.

**CHANNELS**

**2.1** *Installer's Note:* The Channel orientation differs from the typical Prime Design Ford Transit rack installations. Apply Anti-Seize to all M8 T Bolt studs, then attach to Mounts using the indicated hardware. Do not tighten until Step 2.2

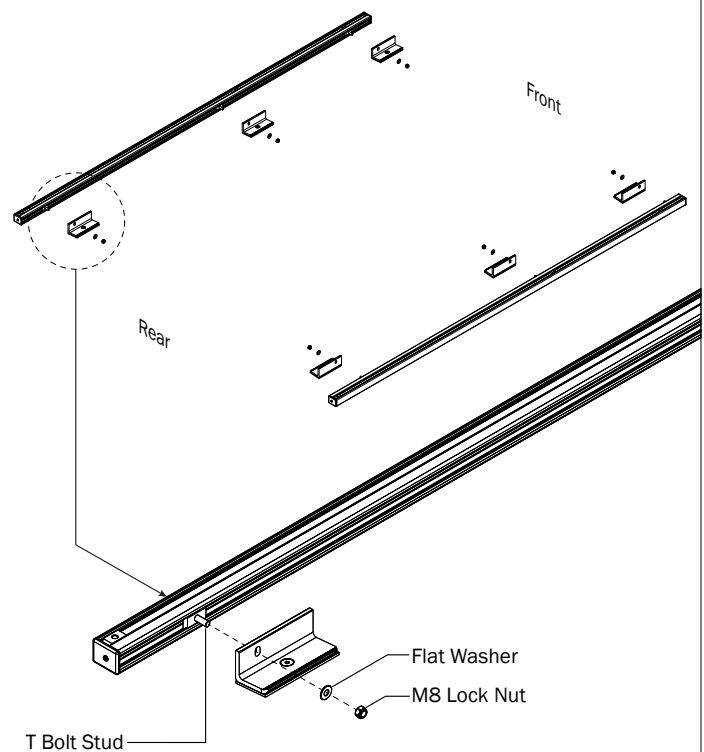



The Channels include three aluminum Strip Nuts per Channel for use in a three Crossbar configuration. For two Crossbar configurations, disregard the center Strip Nut in each Channel.

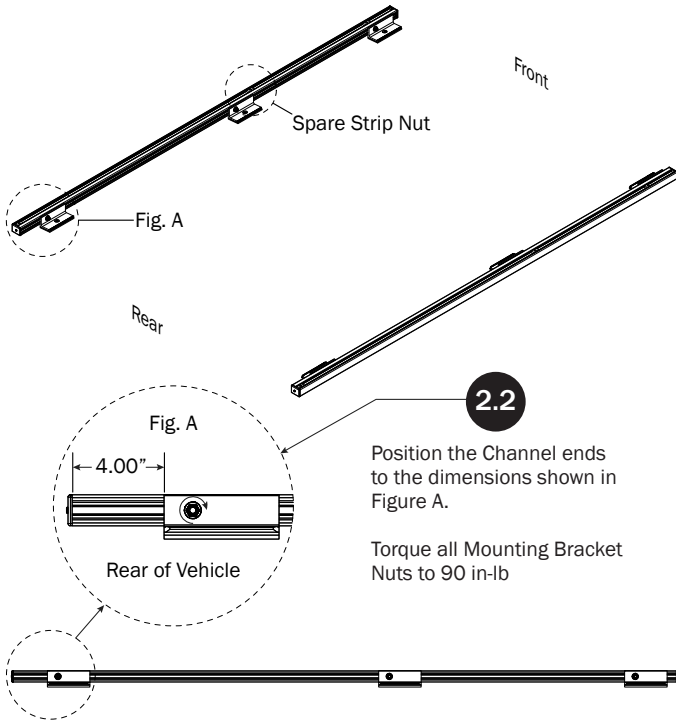

**2.2**

Position the Channel ends to the dimensions shown in Figure A.

Torque all Mounting Bracket Nuts to 90 in-lb

**2.3**

Torque all M8 x 25MM Flat Head Screws to 150 in-lbs. Apply Silicone Sealant to screw heads to seal against water intrusion.

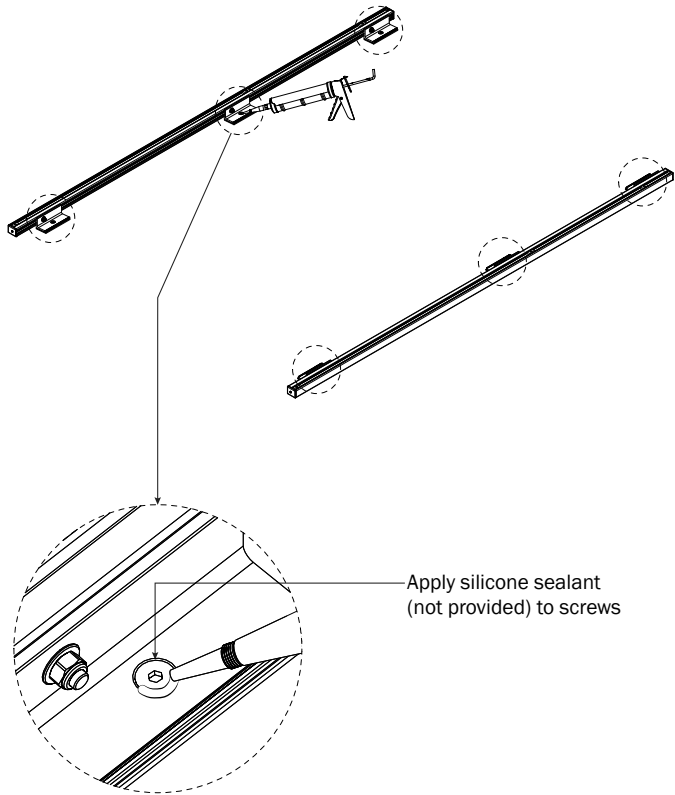

### MOUNTING RACK TO FBM



The assembled rack weighs 100 lbs. To prevent bodily injury and/or vehicle damage, it is recommended to use several people to safely lift and place the rack onto the mounting system.

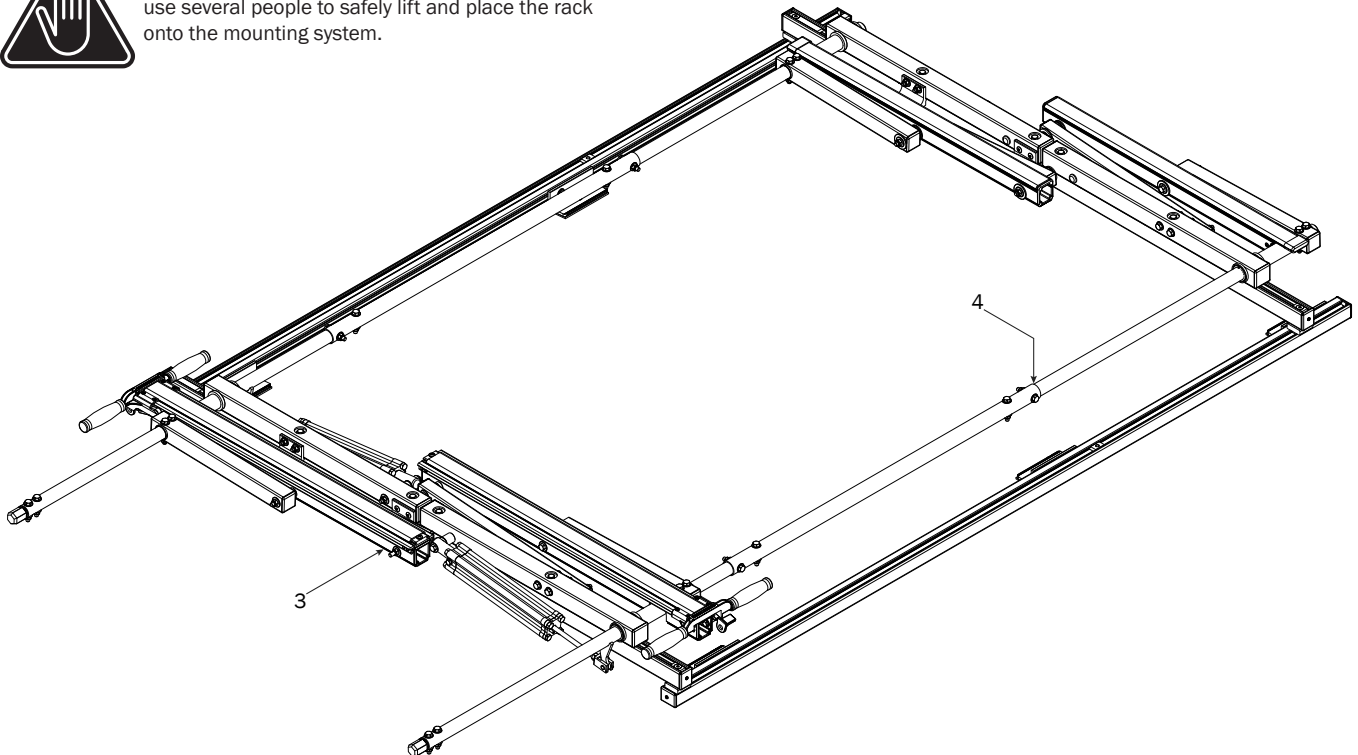

**3.1** Position one Mounting Spacer on each of the four outer Strip Nuts, aligning the bolt holes.

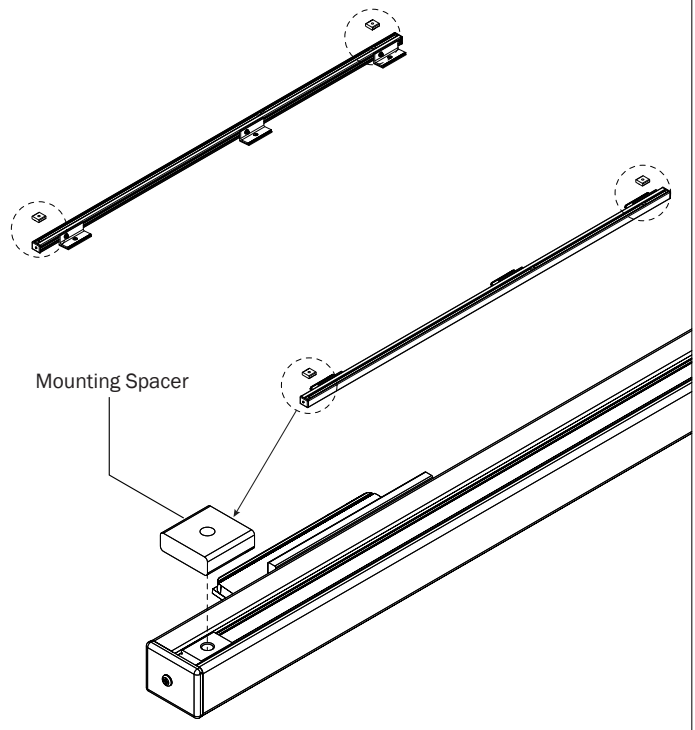

**3.2** Position and place the rack assembly onto the Mounting Spacers.

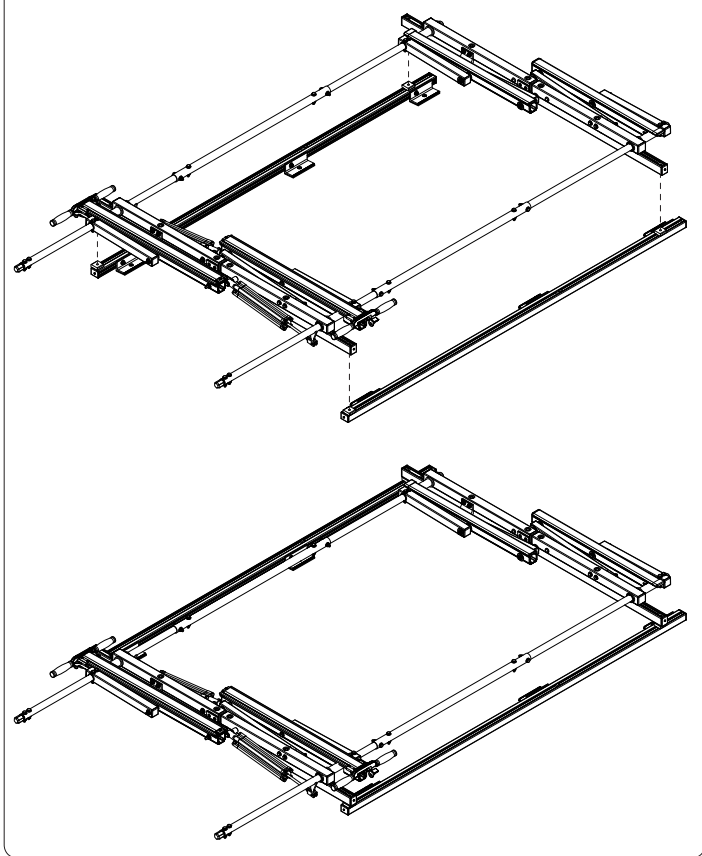

**3.3** Insert the 65MM Flat Head Bolts into each Crossbar Strip Nut, then through the Mounting Spacer and into the Channel Strip Nuts. Do not tighten the bolts at this time.

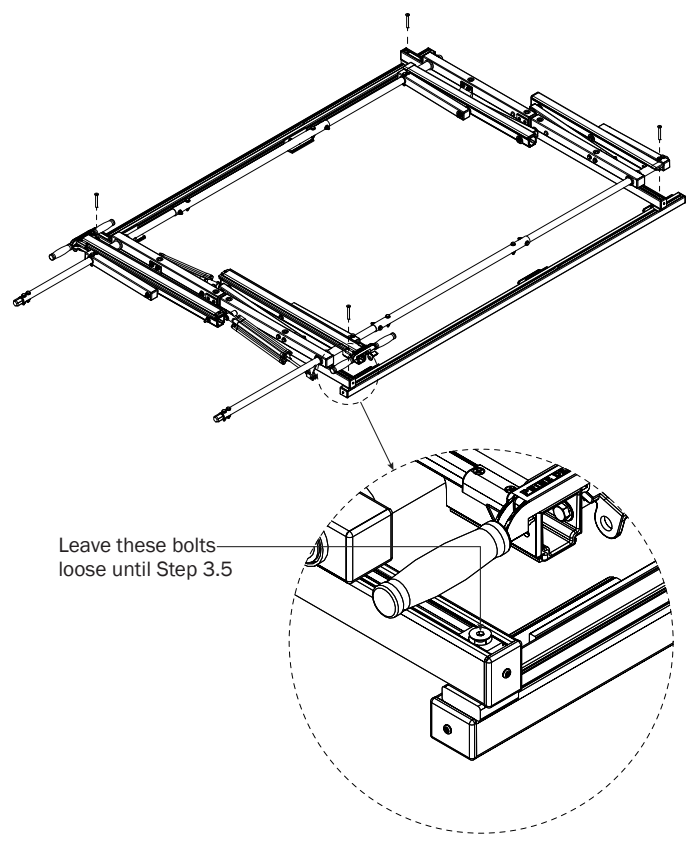

**CROSSBAR ADJUSTMENT**

**3.4** Position and center the Front and Rear Crossbars on the FBM Mounting Channels and Spacers as shown below.

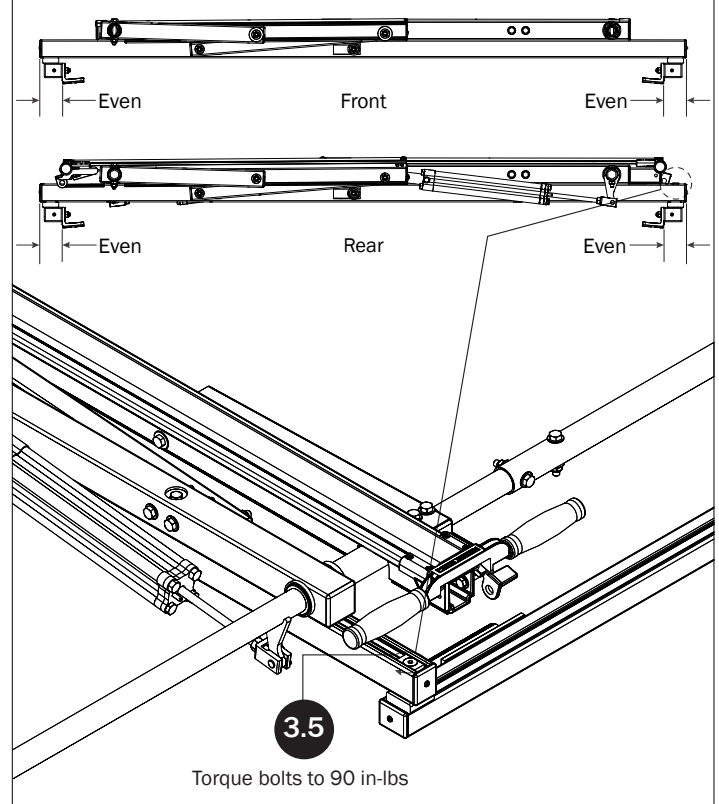



## DRIVE SHAFT SEALING

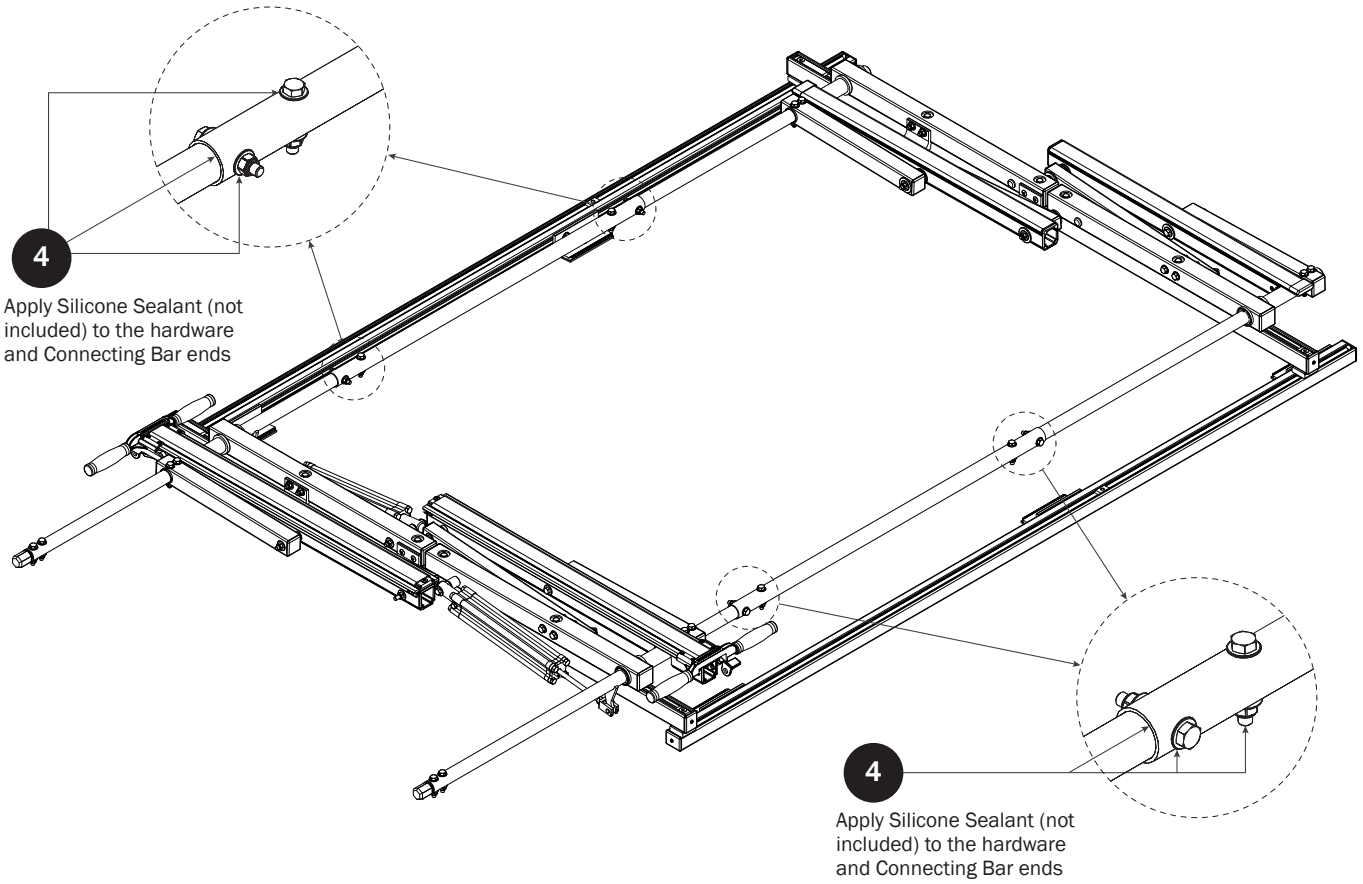

## BOX AND HANDLE



This completes the highest level of ladder rack assembly prior to placing the vehicle into box cars. Place the Ratcheting Handle and Ship Through Box into the van's cargo hold. These parts will be installed and tested by the delivering dealer.

