

VCC-PC11-M

ErgoRack, Promaster City

Two Crossbars, Powder Coat Finish
Rack Weight (empty): 68 lbs

*Callouts in this Configuration Overview indicate full module assemblies only.

For details on individual parts, please refer to the linked Module Overviews below.

- A: [FEA-0008 Clamp Down Assembly](#)
- B: [FBM-1013-BLK Mounting System](#)
- C: [CBR-0001 Crossbar Assembly](#)
- D: [FEA-0008 Clamp Down Assembly](#)

[Modular Assembly Manuals](#)

ErgoRack Van—Load specifications:

Check vehicle manufacturer recommendations for roof capacity weight limits.

CROSSBAR SPACING	STEP LADDER	EXT. LADDER
4 ft Spacing	6 – 8 ft.	16 – 20 ft.
5 ft Spacing	8 – 10 ft.	16 – 24 ft.
6 ft Spacing	8 – 12 ft. [†]	16 – 28 ft.
7 ft Spacing	10 – 12 ft. [†]	20 – 32 ft.
8 ft Spacing	10 – 12 ft. [†]	20 – 36 ft.

[†]Rotation Configurations: 12 ft. step ladders require an extended upper add-on component.

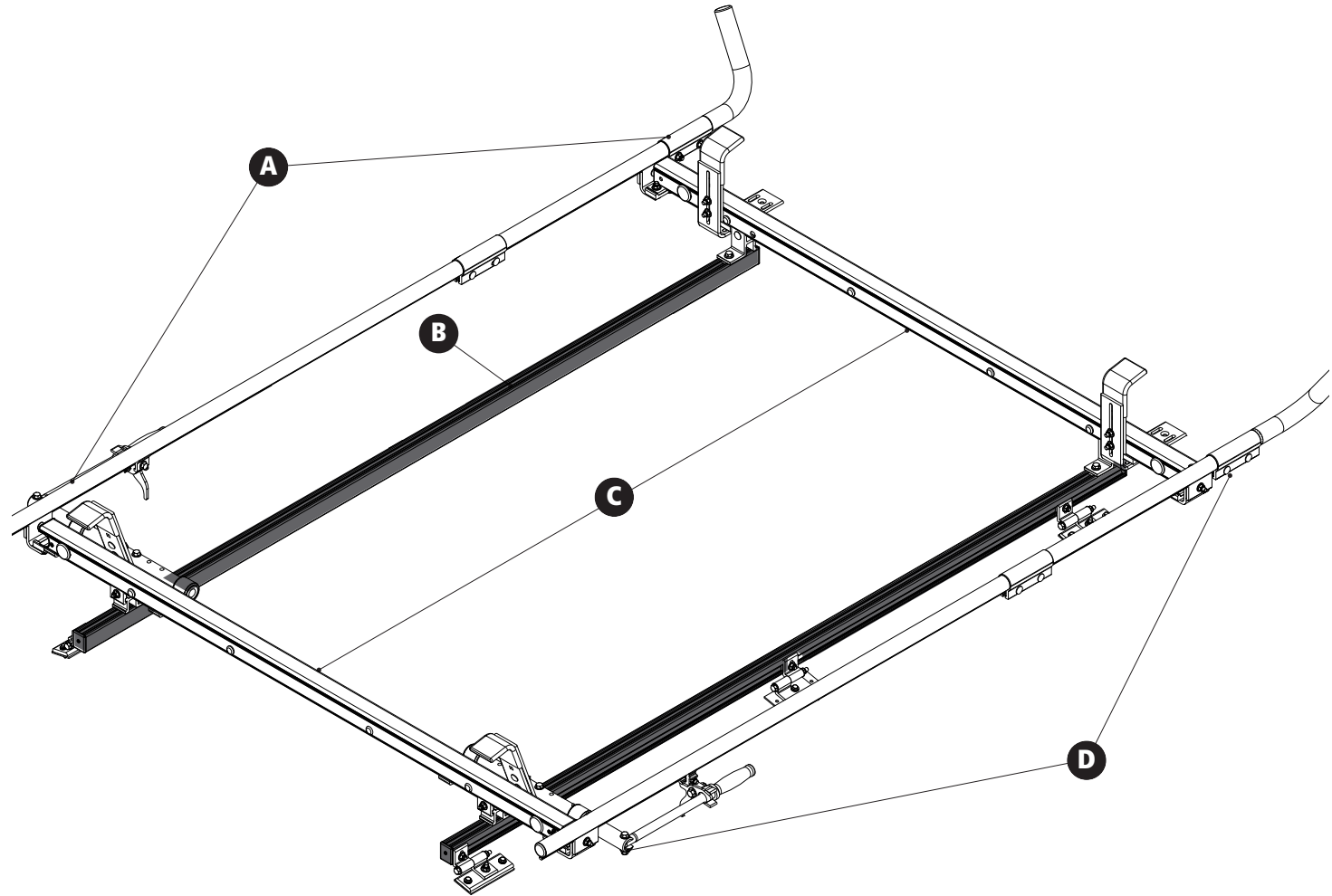

VCC-PC11-M

ErgoRack, Promaster City

Approximate dimensions as shown:

- A: Rack Width 70"
- B: Rack Height 15"
- C: Rear Crossbar Offset (L&R) Even
- D: Mount Spacing L/R..... Set at install
- E: Total Crossbar Spacing..... 6'
- F: Rack Length 90"

Compatible Accessories Available

(Sold Separately)

- 8'–12' Conduit Carriers.....[CON Series](#)
- WorkPro LED Lighting.....[LED Series](#)
- Systems and Safety Components[RVS Series](#)
- Safety monitoring.....[DS2 Series](#)

