

## VBB-PC11-M

### ErgoRack, Promaster City

Two Crossbars, Powder Coat Finish  
Rack Weight (empty): 36 lbs

\*Callouts in this Configuration Overview indicate full module assemblies only.

For details on individual parts, please refer to the linked Module Overviews below.

- A: ..... [FBM-1013-BLK Mounting System](#)
- B: ..... [CBR-0001 Crossbar Assembly](#)
- C: ..... [FEA-0001 End Stop Assembly \(x2\)](#)

[Modular Assembly Manuals](#)

### ErgoRack Van—Load specifications:

Check vehicle manufacturer recommendations for roof capacity weight limits.

CROSSBAR SPACING	STEP LADDER	EXT. LADDER
4 ft Spacing	6 – 8 ft.	16 – 20 ft.
5 ft Spacing	8 – 10 ft.	16 – 24 ft.
6 ft Spacing	8 – 12 ft. <sup>†</sup>	16 – 28 ft.
7 ft Spacing	10 – 12 ft. <sup>†</sup>	20 – 32 ft.
8 ft Spacing	10 – 12 ft. <sup>†</sup>	20 – 36 ft.

<sup>†</sup>Rotation Configurations: 12 ft. step ladders require an extended upper add-on component.

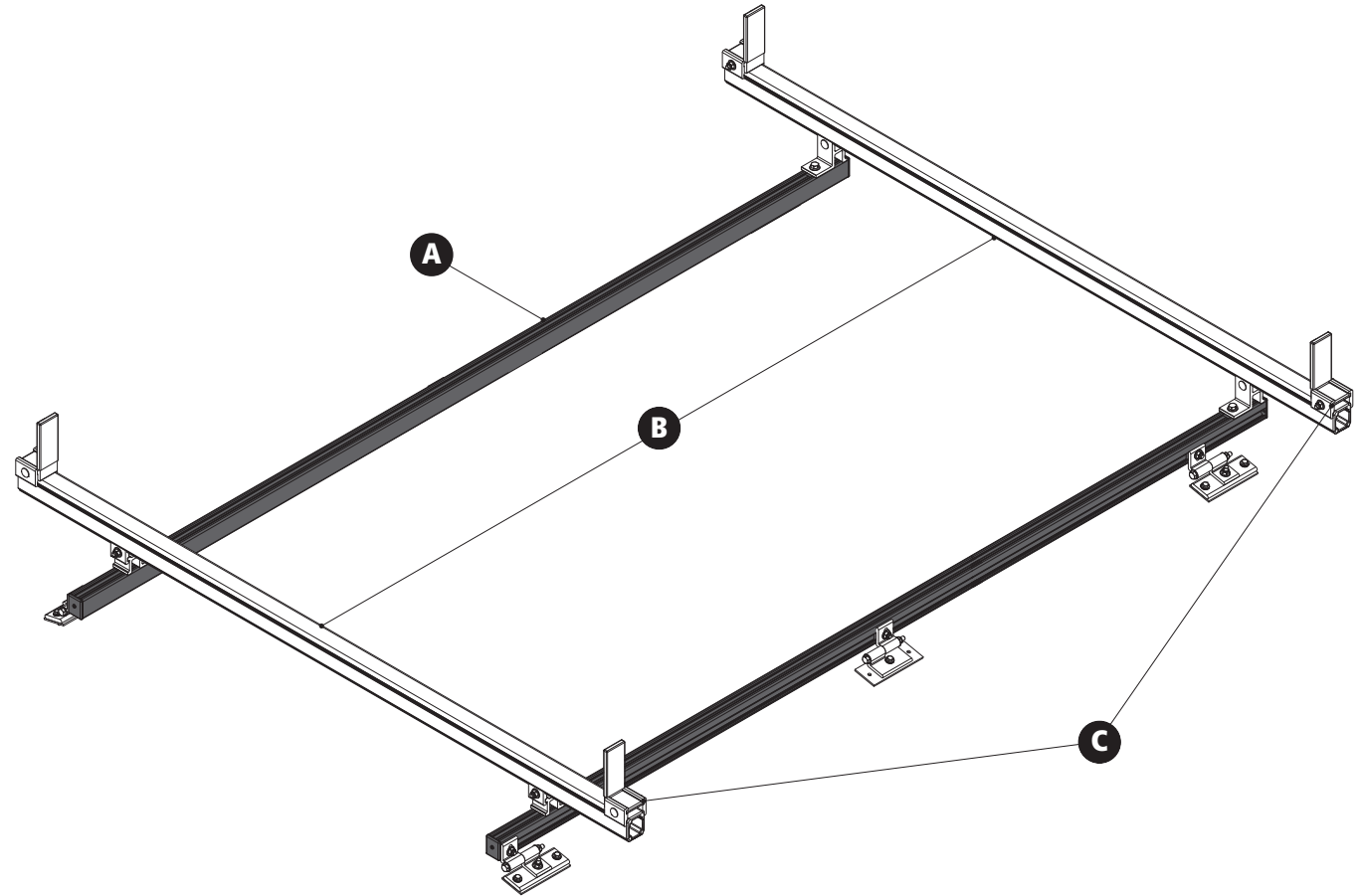

## VBB-PC11-M

### ErgoRack, Promaster City

Approximate dimensions as shown:

- A: Rack Width ..... 62"
- B: Rack Height ..... 13"
- C: Rear Crossbar Offset (L&R) ..... Even
- D: Mount Spacing L/R..... Set at install
- G: Total Crossbar Spacing..... 6'
- H: Rack Length..... 78"

#### Compatible Accessories Available

(Sold Separately)

- Retractable Ratchet Tie-Down..... [ACC-8000](#)
- 8'–12' Conduit Carriers..... [CON Series](#)
- WorkPro LED Lighting..... [LED Series](#)
- Systems and Safety Components ..... [RVS Series](#)
- Safety monitoring..... [DS2 Series](#)

