

# PRIME DESIGN™

A Safe Fleet Brand

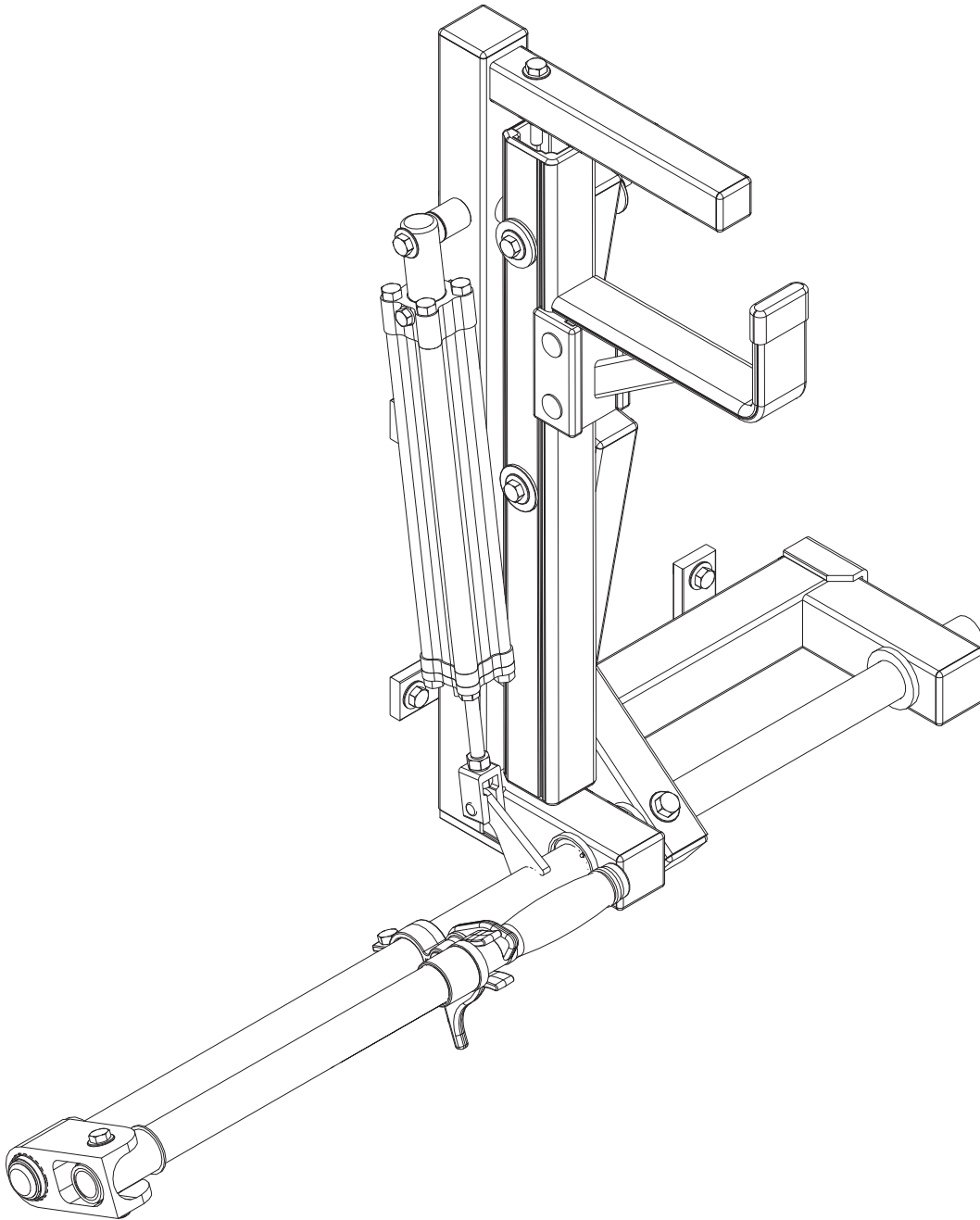

PRIME DESIGN, A SAFE FLEET BRAND

Address: 580 Opperman Drive, Eagan, MN 55123 • Toll Free: 1.8.PRIME.RACK

Fax: 651-552-1799 • Email: [info@primedesign.net](mailto:info@primedesign.net) • Website: [www.primedesign.net](http://www.primedesign.net)

CONTENTS OVERVIEW

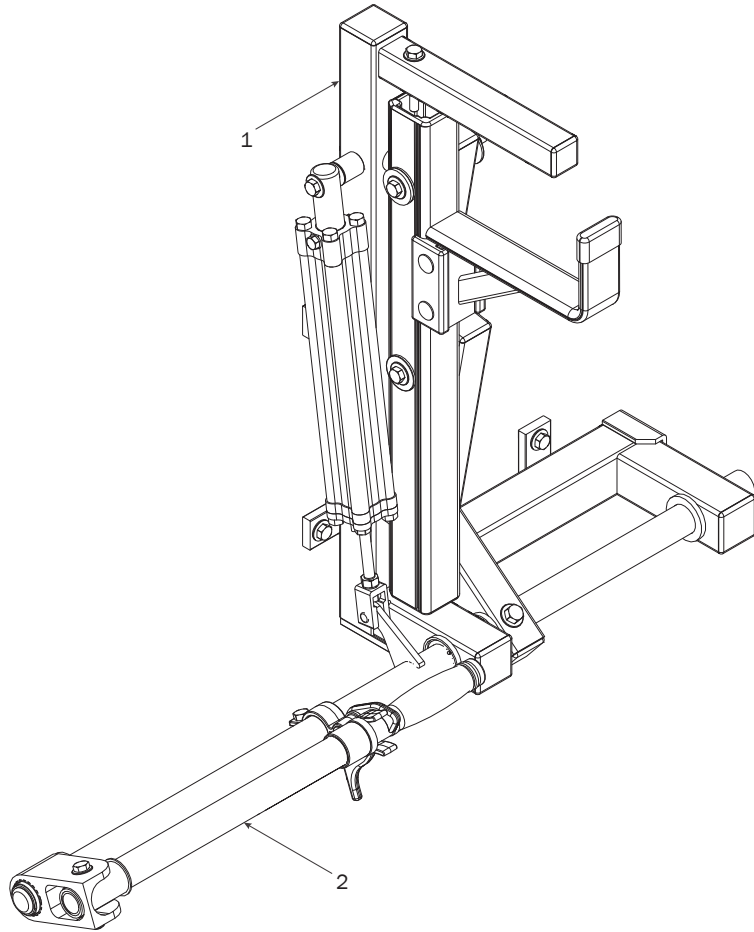

1—Rear Rotation Assembly..... (Qty 1)

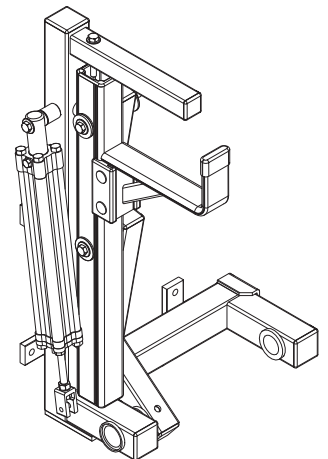

2—Rear Drive Shaft..... (Qty 1)  
Right Hand, 36.00"

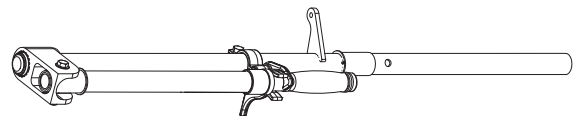

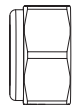

M8 Lock Nut (6X)



3/8" Lock Nut (2X)

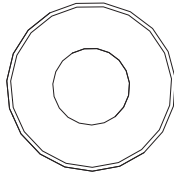

3/8" Flat Washer (2X)

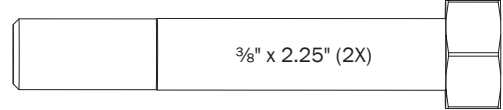

3/8" x 2.25" (2X)



Neoprene Washer (6X)

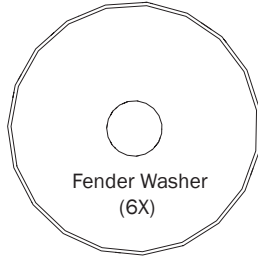

Fender Washer (6X)

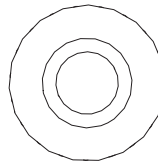

5/16" Seal Washer (6X)



M8 x 30MM (6X)



Cotter Pin (1X)



Clevis Pin (1X)



Anti-Seize (1X)



Lubricant (1X)

## UTILITY BODY MOUNTING

- 0.1** Drill holes into the Service Body mounting location according to dimensions shown.

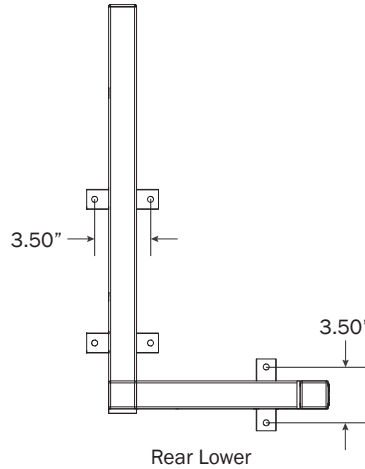

- 0.2** Position and align the vertical Uprights until the mounting holes realign to the body holes drilled during Steps 0.1.

Using the fastening hardware shown below, attach the vertical Uprights to the Utility Body. The Neoprene Washer, Fender Washer, and Locknut install from the inside of the Utility Body in the order shown, while the Bolt and Seal Washer install from the outside.

**0.3**

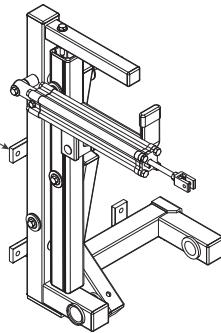

Torque to 90 in-lbs

**0.4**

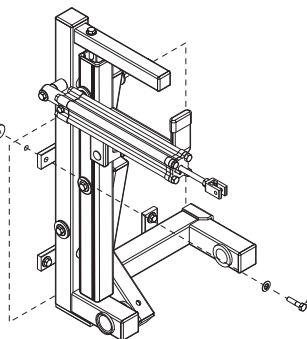

### Mounting Hardware (8X)

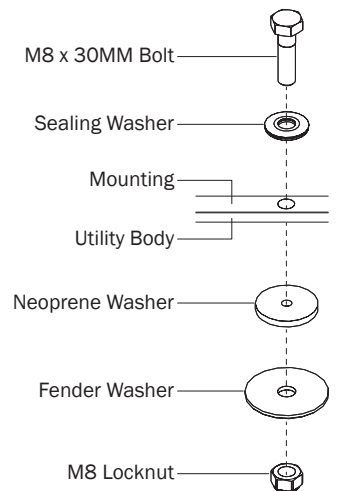

# RIGHT ROTATION ASSEMBLY SEQUENCE

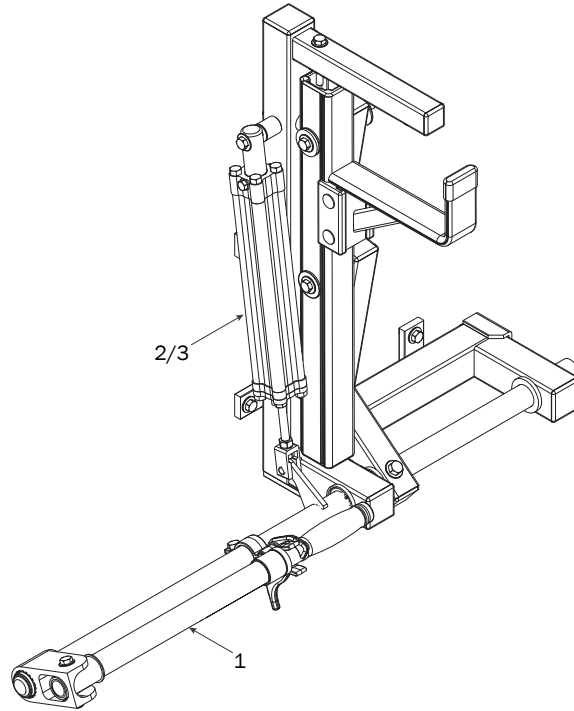

## REAR DRIVE SHAFT

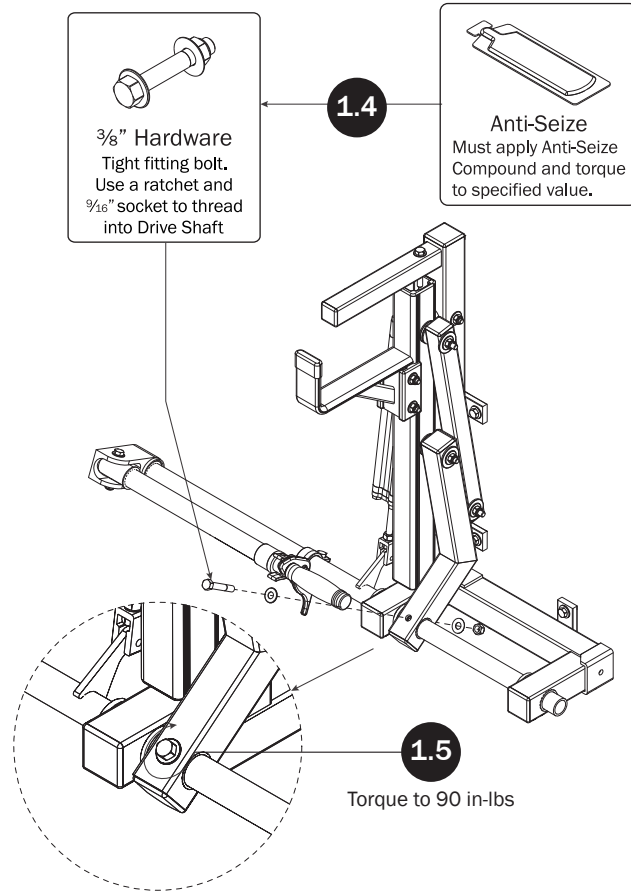
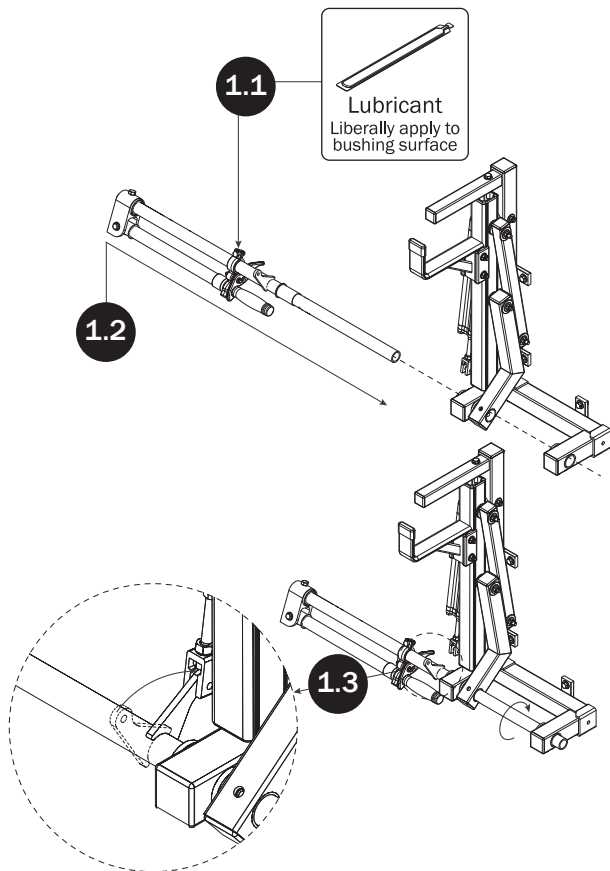

**CYLINDER HARDWARE**

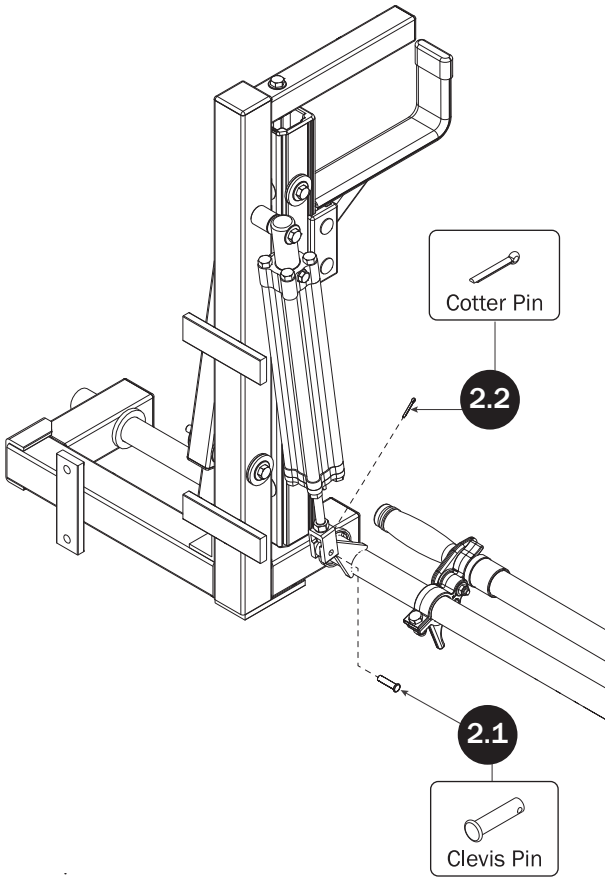

**CYLINDER ADJUSTMENT**

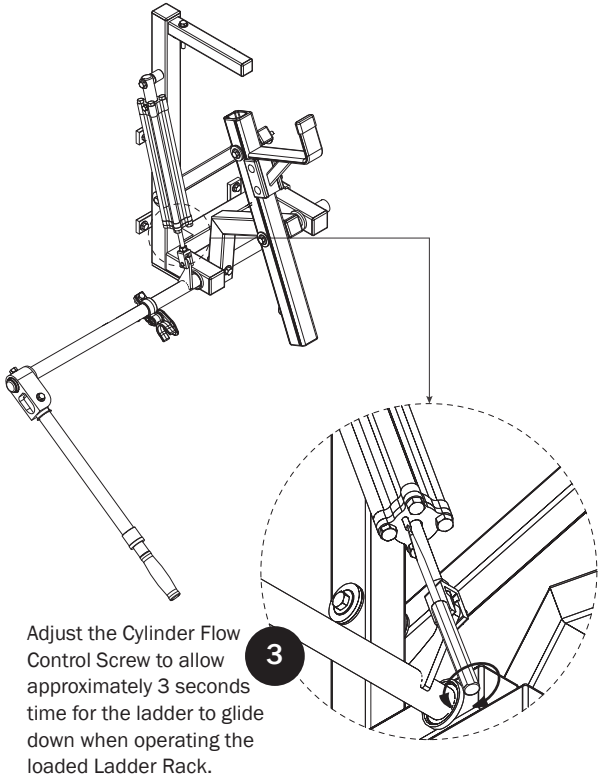

Page Intentionally Left Blank

