

PRIME DESIGN™

A Safe Fleet Brand

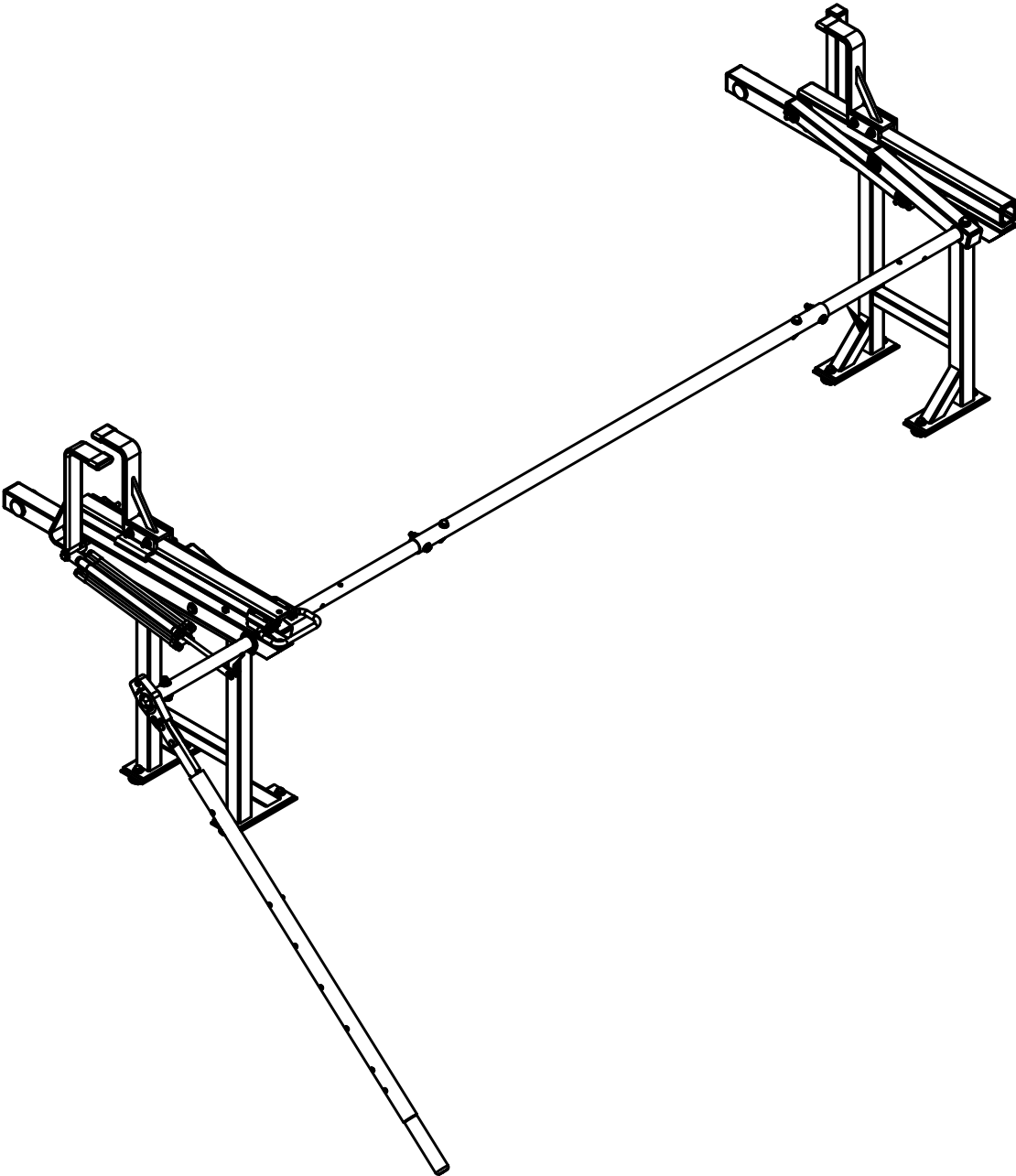

PRIME DESIGN, A SAFE FLEET BRAND
Address: 580 Opperman Drive, Eagan, MN 55123 • Toll Free: 1.8.PRIME.RACK
Fax: 651-552-1799 • Email: info@primedesign.net • Website: www.primedesign.net

UXR
0026

CONTENTS OVERVIEW

NOTE: The images shown are for illustrative purposes only and may not be an exact representation of the product.

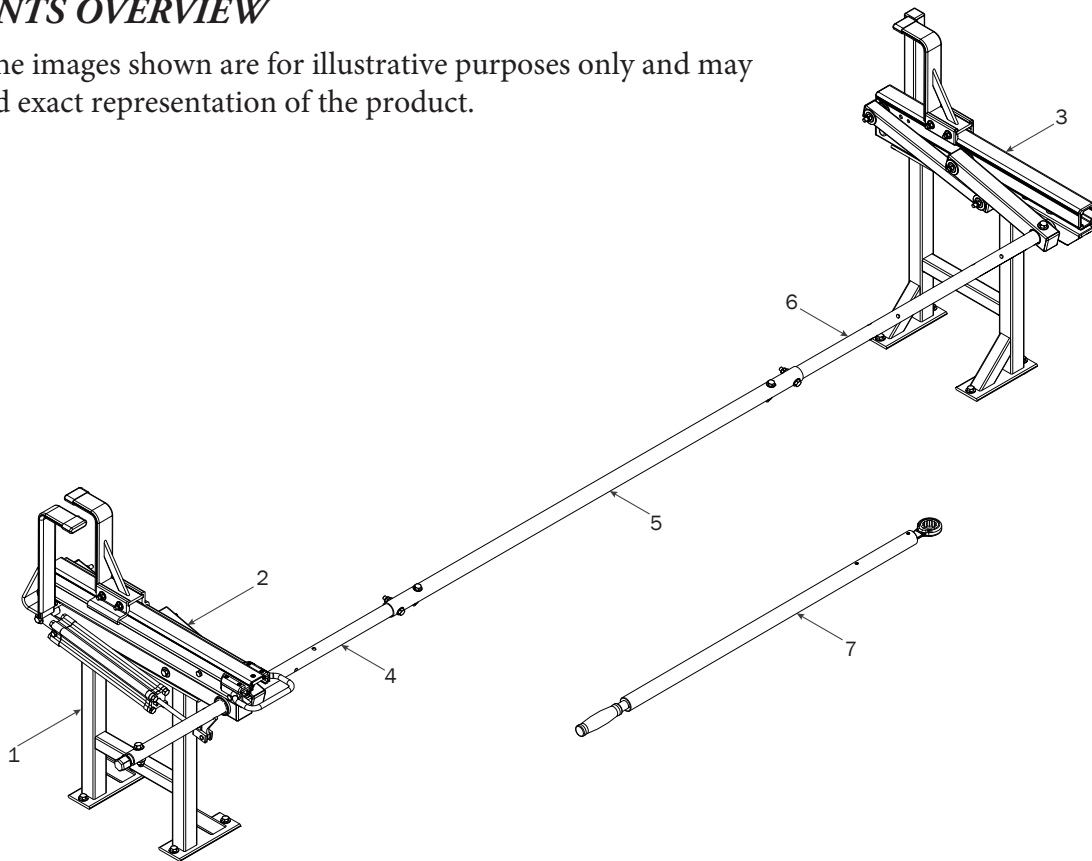

1—Utility Base Standing Mount..... (Qty 2)

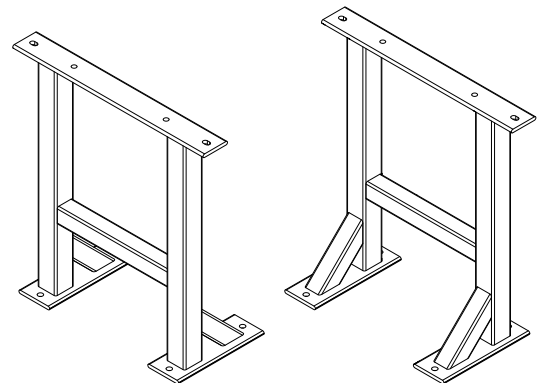

2—Rear Rotation Assembly..... (Qty 1)

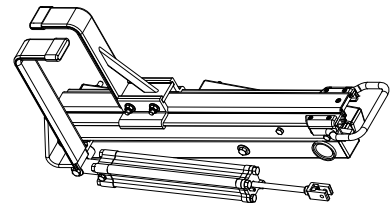

3—Front Rotation Assembly..... (Qty 1)

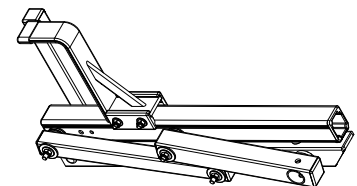

4—Rear Drive Shaft..... (Qty 1)
Right Hand, Hex Drive, 34.00”

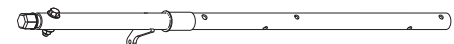

5—Connecting Bar..... (Qty 1)
48.00"



6—Front Drive Shaft (Qty 1)
B Version, 35.75"



7—Ratcheting Handle (Qty 1)
Hex Drive



8—HKT-0122 (Not called out in Overview)..... (Qty 1)



M8 x 35MM (8X)

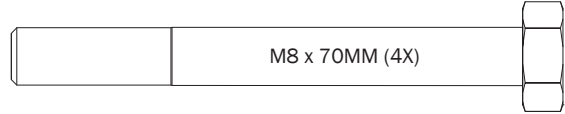

M8 x 70MM (4X)

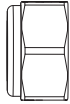

M8 Lock Nut (12X)

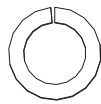

Lock Washer (4X)

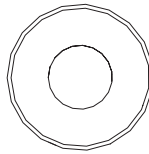

5/16" Flat Washer (8X)



Anti-Seize (1X)

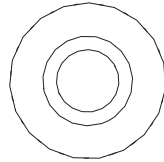

Sealing Washer (8X)

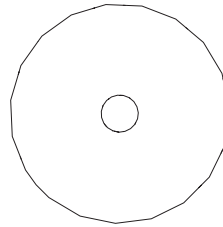

Neoprene Washer (8X)

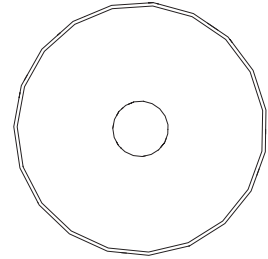

Fender Washer (8X)

9—HKT-8163 (Not called out in Overview)..... (Qty 1)

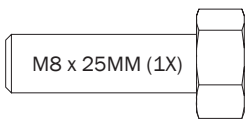

M8 x 25MM (1X)

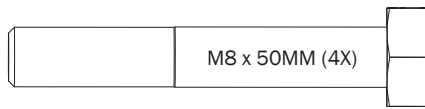

M8 x 50MM (4X)

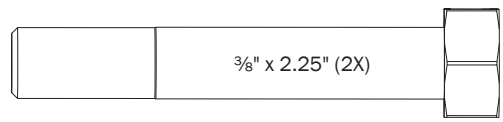

3/8" x 2.25" (2X)

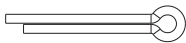

Cotter Pin (1X)



Clevis Pin (1X)

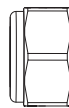

M8 Lock Nut (5X)



3/8" Lock Nut (2X)

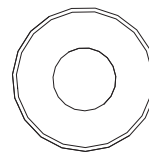

5/16" Flat Washer (10X)

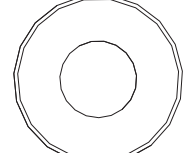

3/8" Flat Washer (4X)

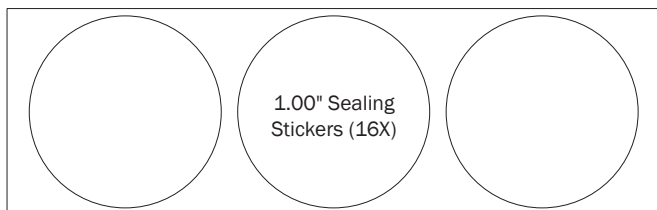

1.00" Sealing Stickers (16X)



Anti-Seize (1X)

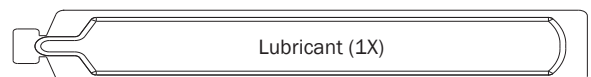

Lubricant (1X)

UTB-2316 MOUNTING BRACKETS

0.1 8.00 Ft: Drill holes into the Service Body mounting location according to dimensions shown.

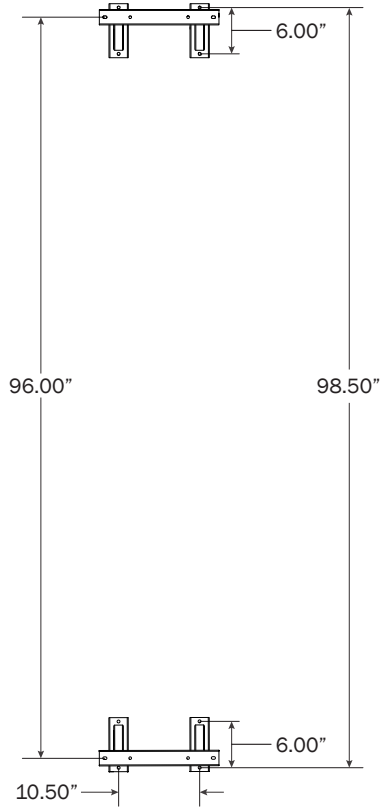

0.2 7.00 Ft: Drill holes into the Service Body mounting location according to dimensions shown.

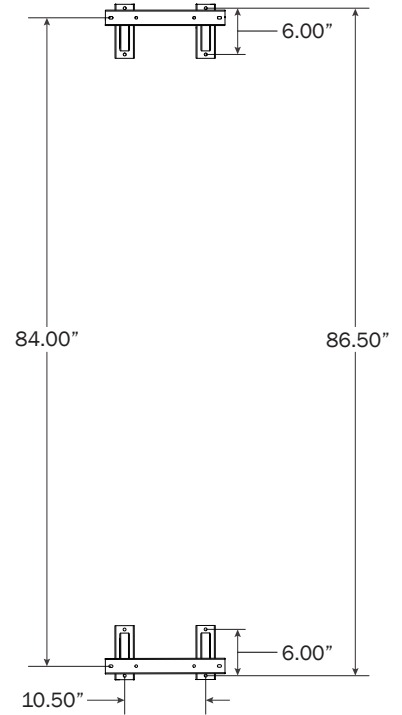

0.3 6.00 Ft: Drill holes into the Service Body mounting location according to dimensions shown.

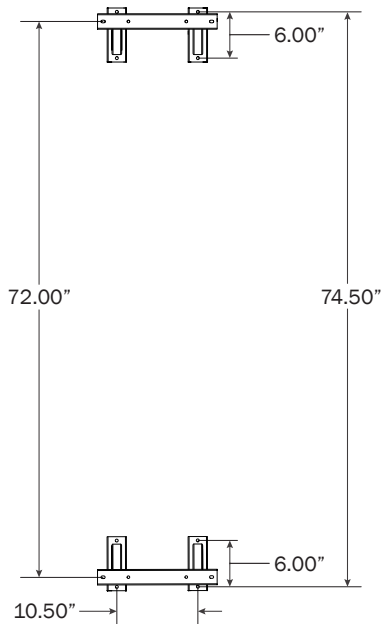

0.4 5.00 Ft: Drill holes into the Service Body mounting location according to dimensions shown.

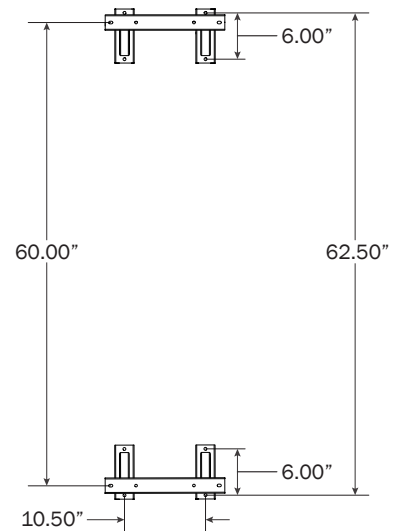

0.5 Apply Anti-Seize compound to Mounting Bracket bolts. The Bolt and Seal Washers are on the outside as shown.

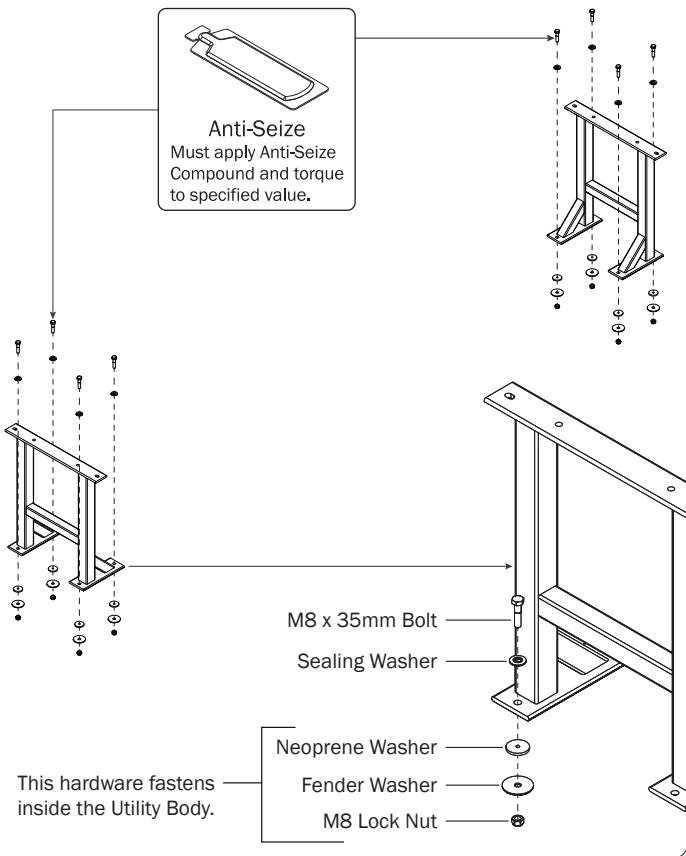

0.6
Torque all Mounting Bracket bolts to 90 in-lbs.

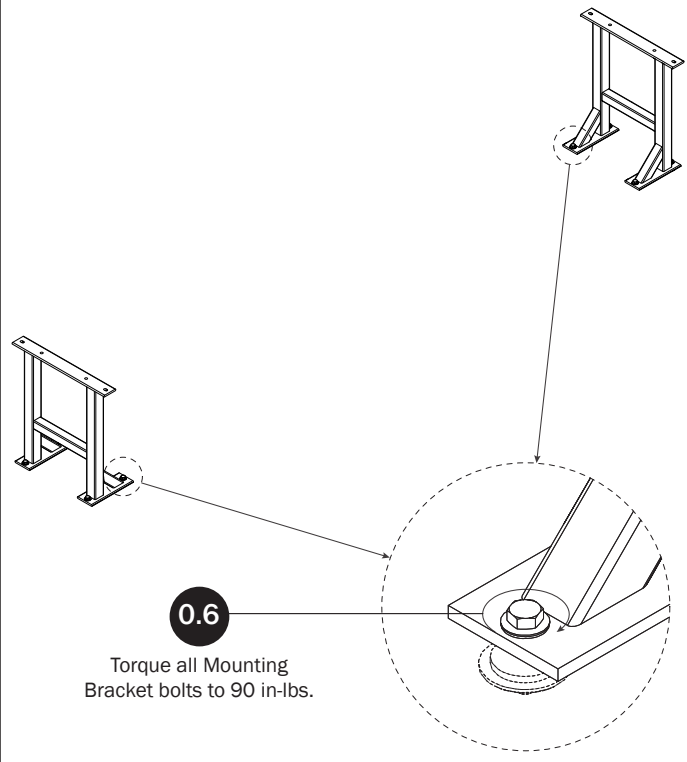

RIGHT ROTATION ASSEMBLY SEQUENCE



Installer's Note: Due to variances between Utility Body manufacturers, the UTB Mounting Bracket's top plate comes undrilled from the factory. After installing the Mounting Brackets, determine the correct positioning of the Rotation Assembly according to your Utility Body, then mark the hole locations on the Mounting Brackets based upon the holes found in the Lower as shown in Steps 1.1-2.2

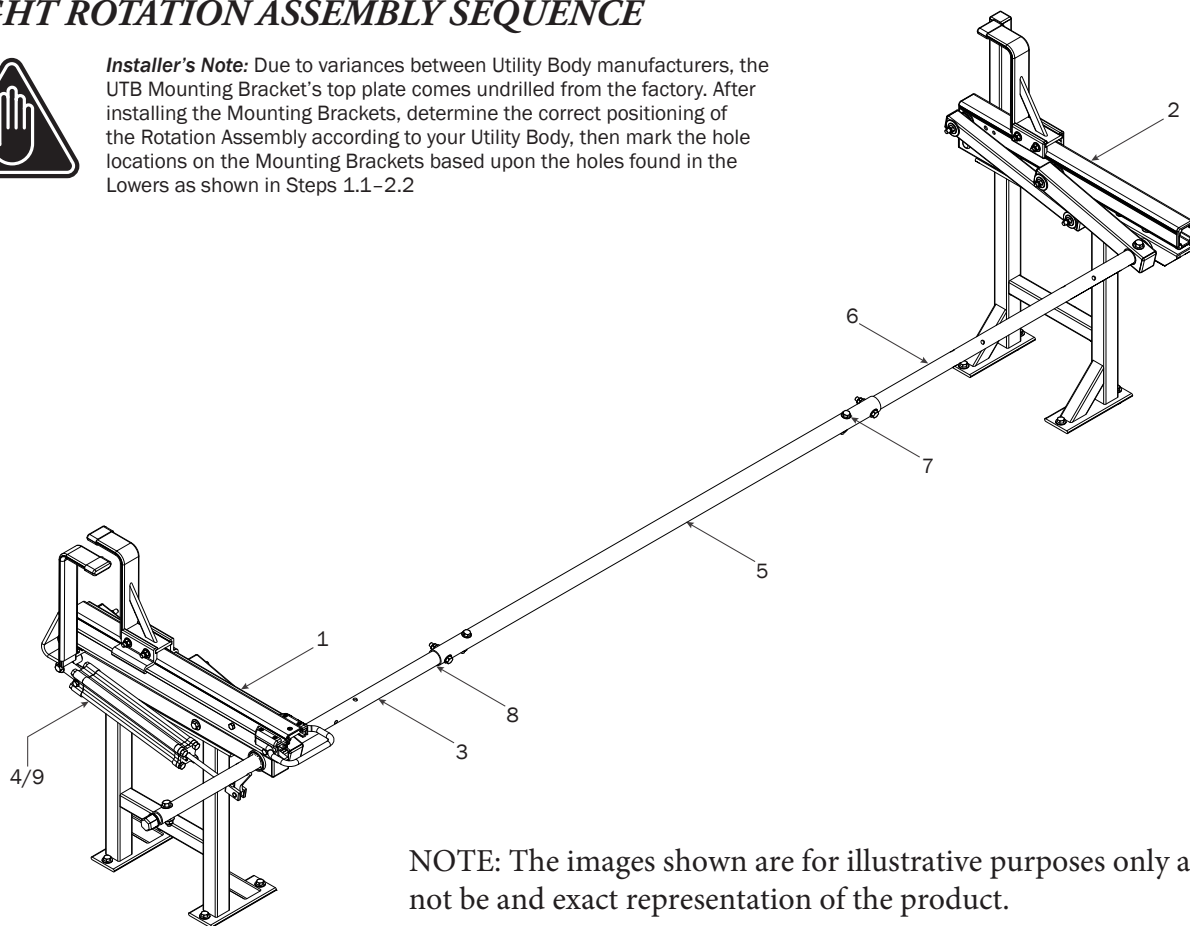

NOTE: The images shown are for illustrative purposes only and may not be an exact representation of the product.

REAR ROTATION ASSEMBLY

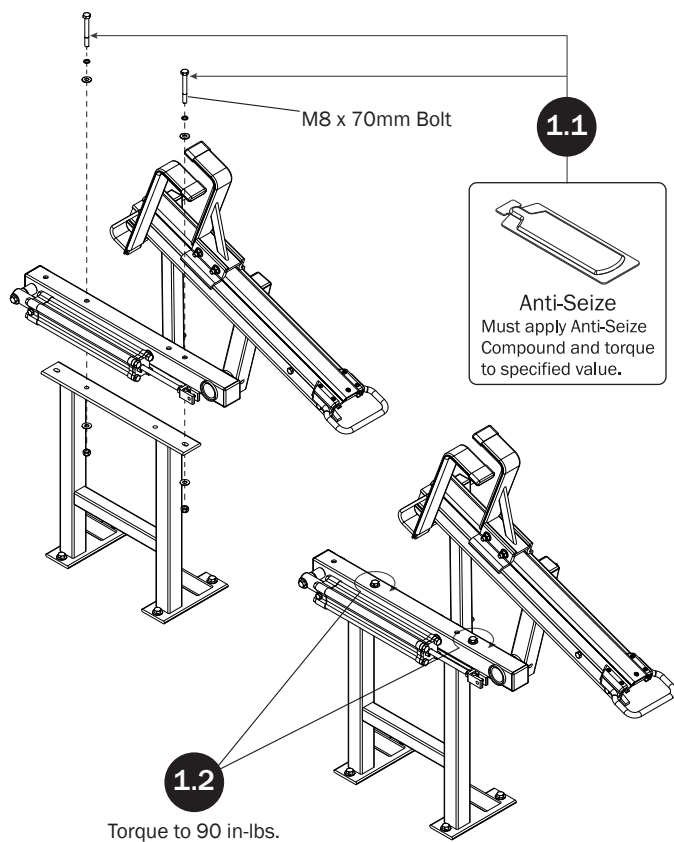

FRONT ROTATION ASSEMBLY

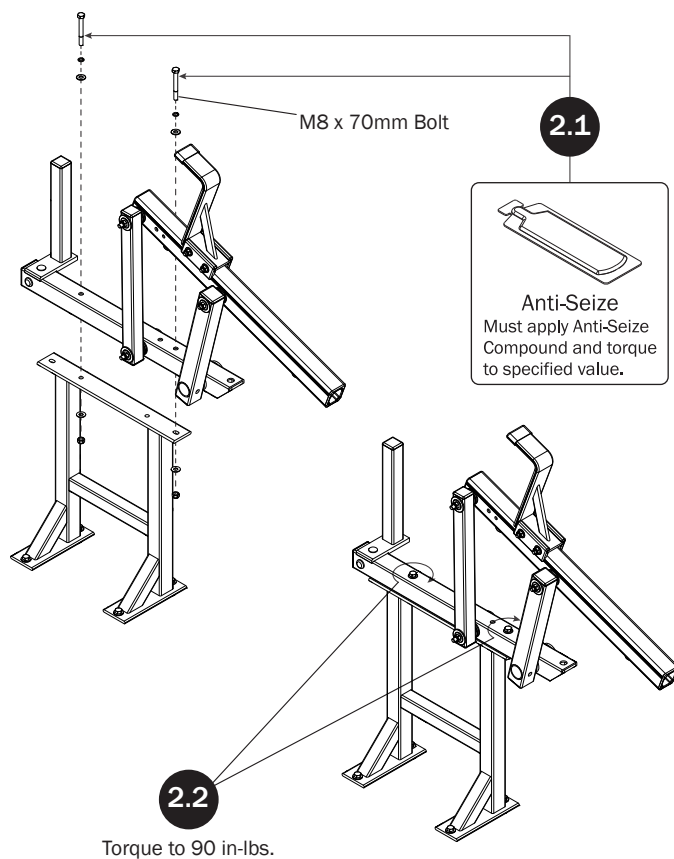

REAR DRIVE SHAFT

NOTE: For instructional clarity, the FBM Mounting System will not be shown for the remainder of this Assembly Manual.

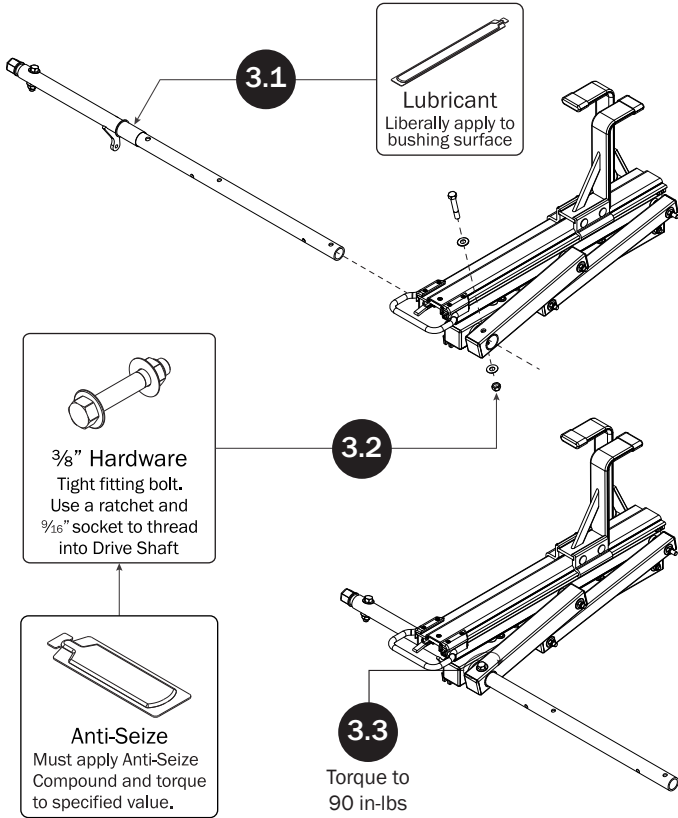

CYLINDER HARDWARE

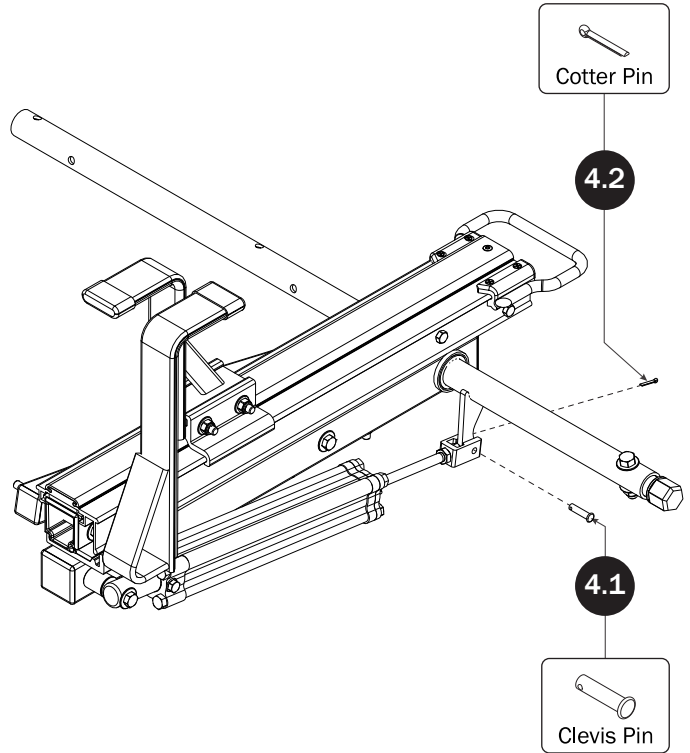

CONNECTING BAR

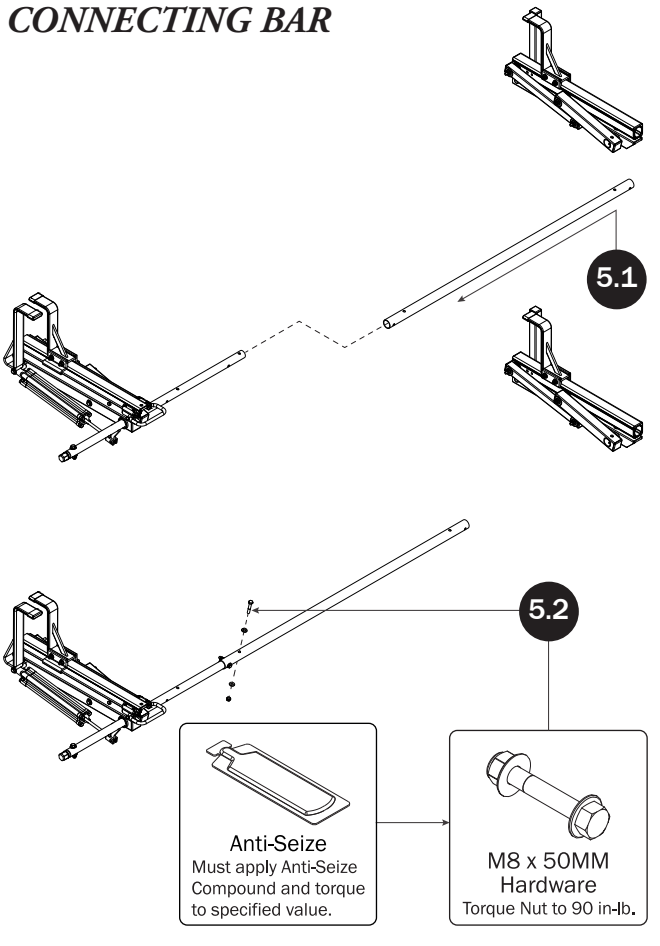

FRONT DRIVE SHAFT

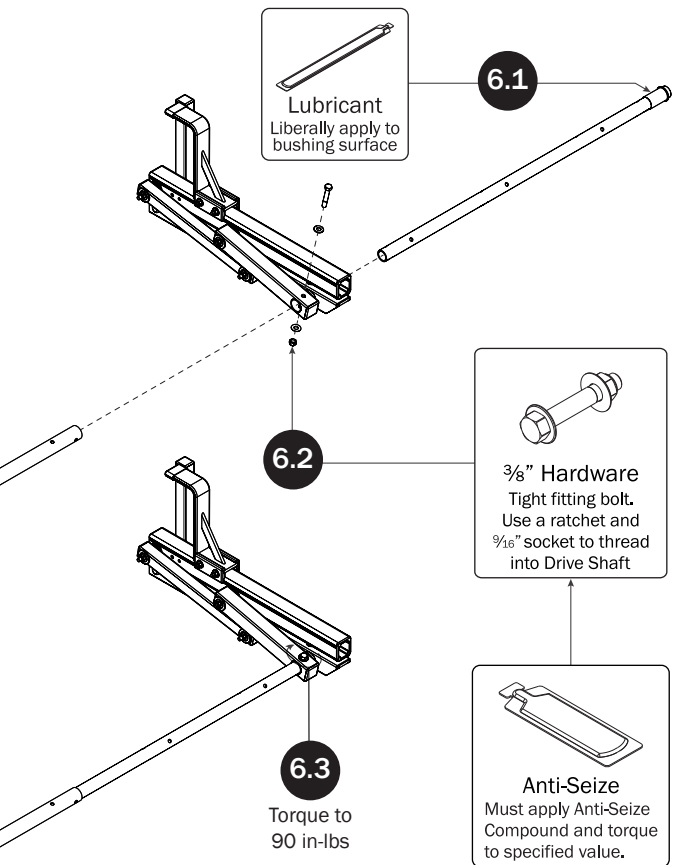

CONNECTING BAR FASTENERS

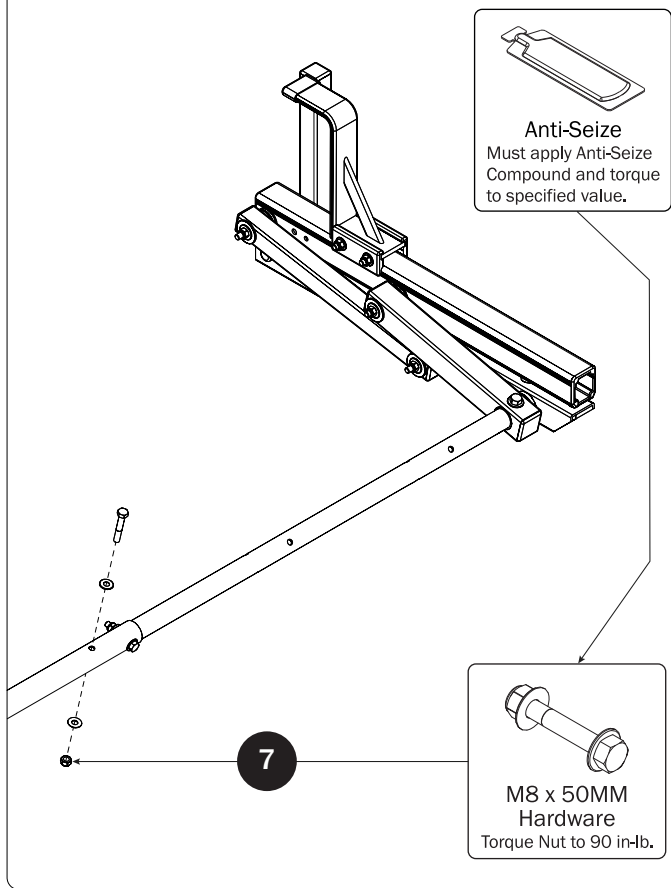

DRIVE SHAFT SEALING

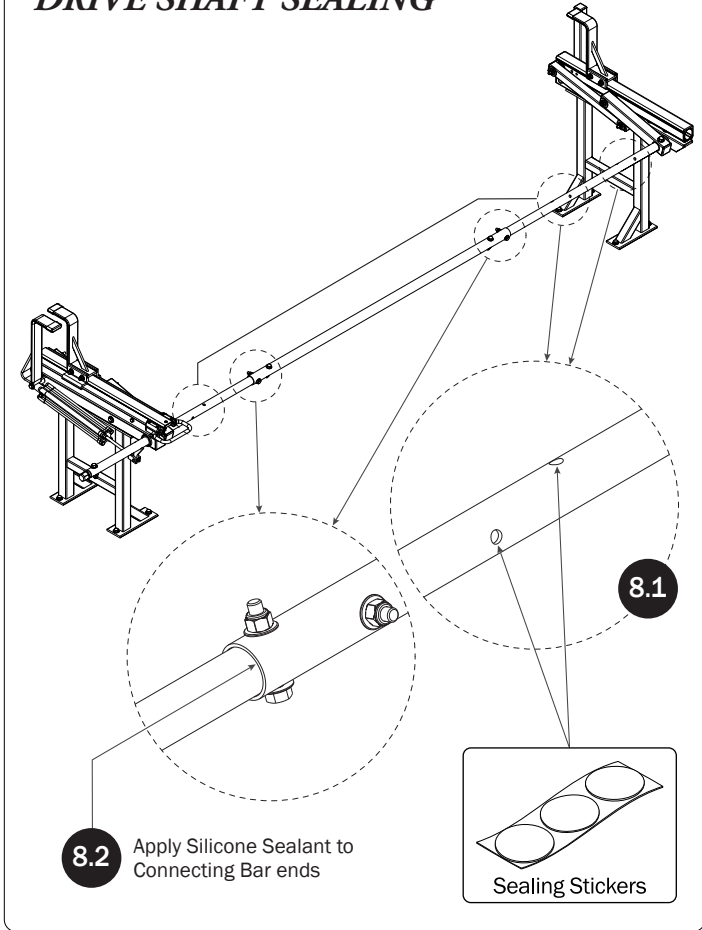

CYLINDER ADJUSTMENT

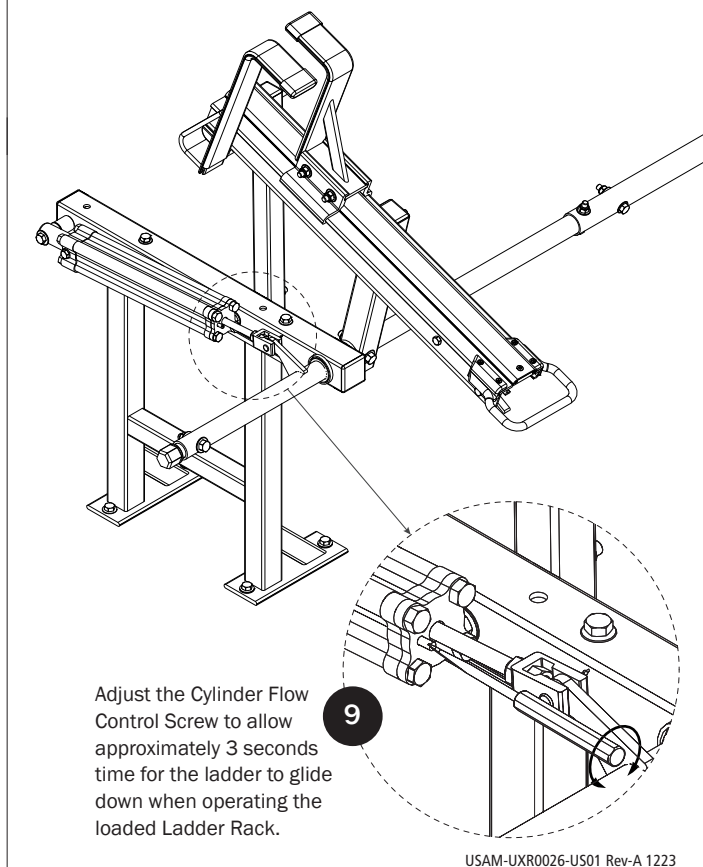

USAM-UXR0026-US01 Rev-A 1223