

PRIME DESIGN™

A Safe Fleet Brand

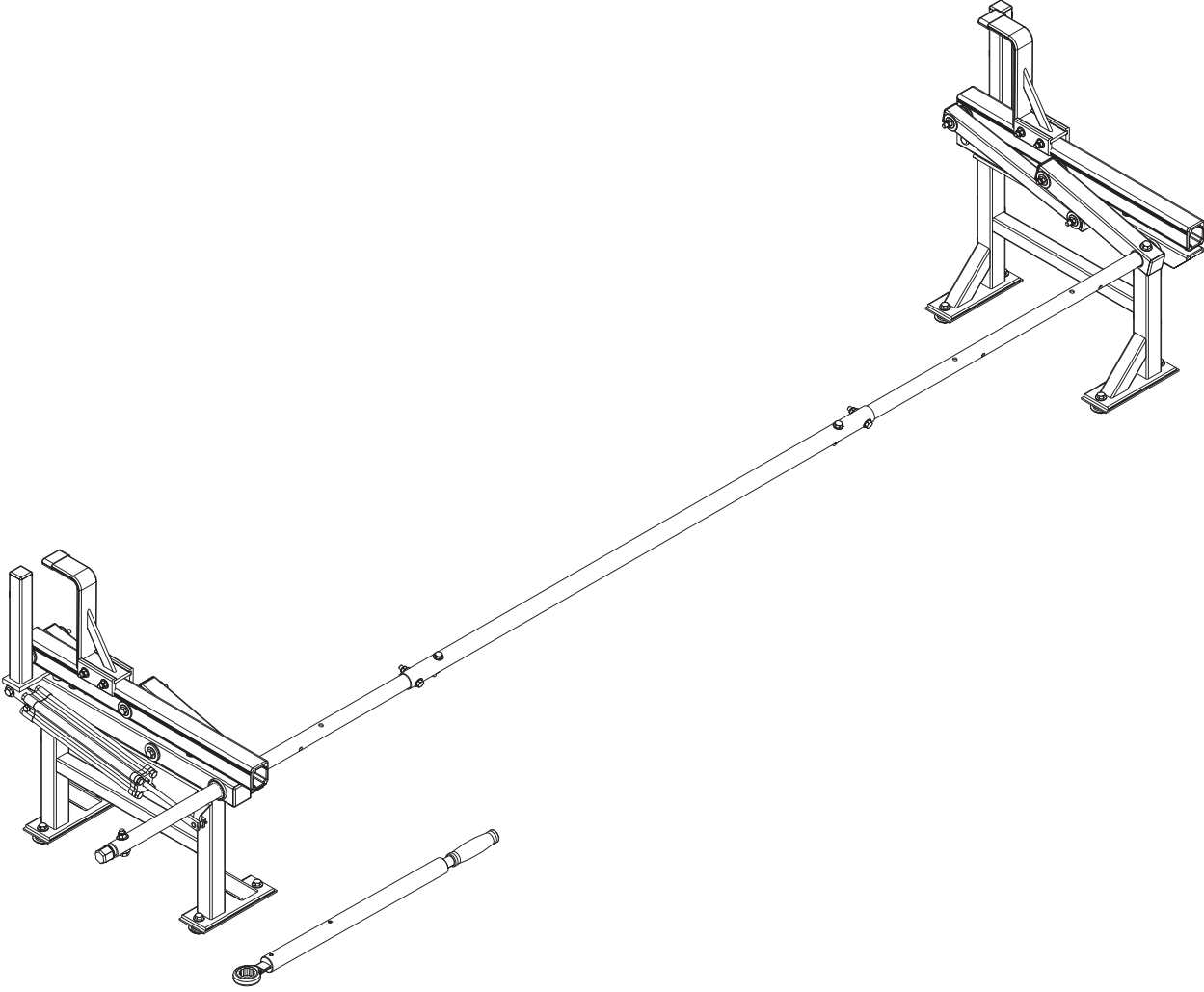

UXR
0020

CONTENTS OVERVIEW

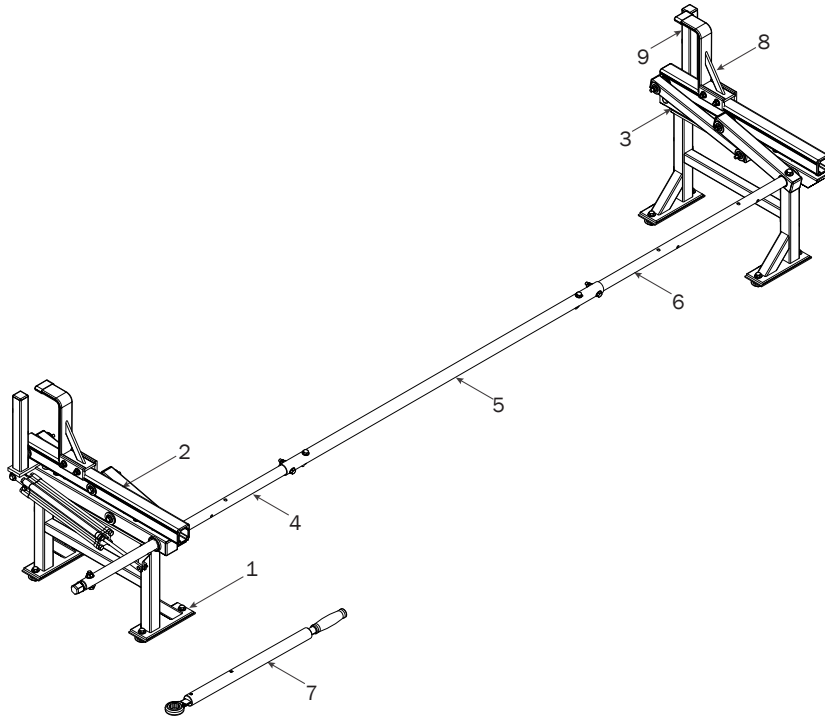

1—Utility Base Standing Mount..... (Qty 2)

2—Rear Rotation Assembly..... (Qty 1)

3—Front Rotation Assembly..... (Qty 1)

4—Rear Drive Shaft..... (Qty 1)
Right Hand, Hex, 34.00"

5—Connecting Bar..... (Qty 1)
48.00"

6—Front Drive Shaft (Qty 1)
B Version, 35.75"

7—Ratcheting Handle Assembly (Qty 1)
With Hardware

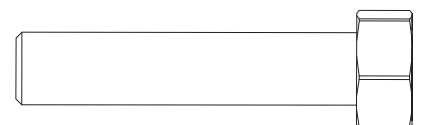
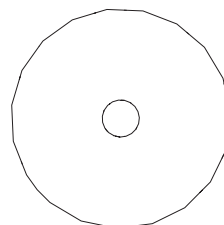
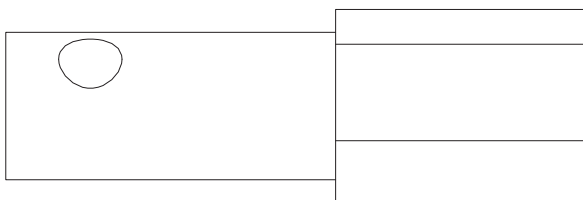
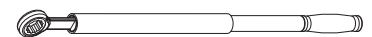
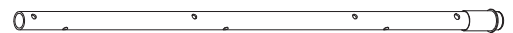
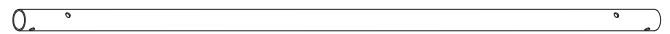
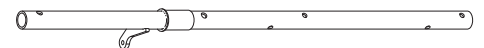
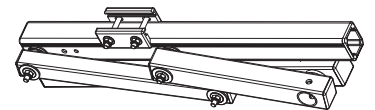
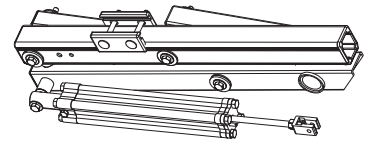
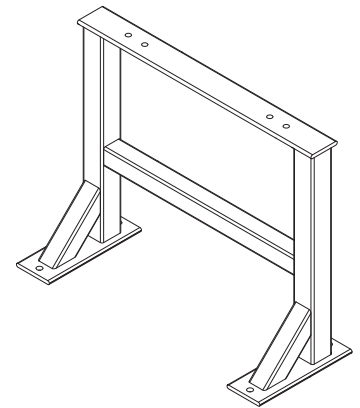

8-Z Post (Qty 2)
Adjustable, 7.25"

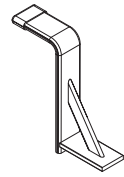

9-L Post (Qty 2)
9.25"

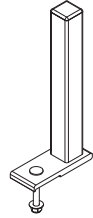

HKT-8163-Rotation Hardware Kit

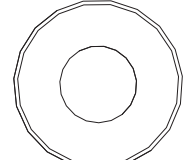
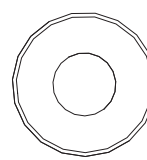
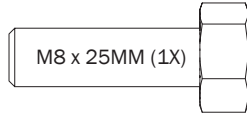
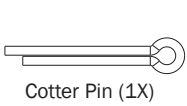
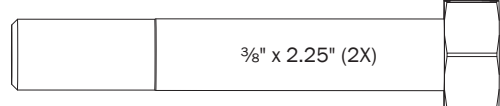
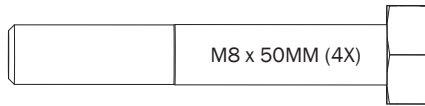

M8 Lock Nut (5X)

3/8" Lock Nut (2X)

5/16" Flat Washer (10X)

3/8" Flat Washer (4X)

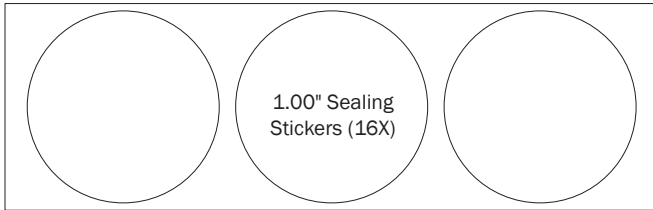

1.00" Sealing Stickers (16X)



Anti-Seize (1X)

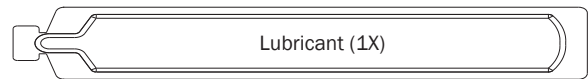

Lubricant (1X)

HKT-0122 Mounting Hardware Kit

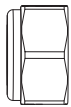

Lock Nut (12X)

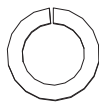

Lock Washer (4X)

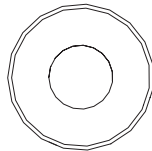

Flat Washer (8X)



M8 x 70MM (4X)

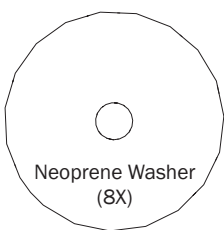

Neoprene Washer (8X)

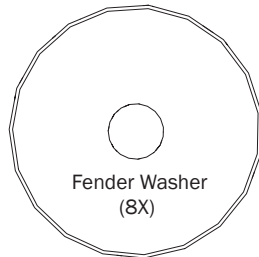

Fender Washer (8X)

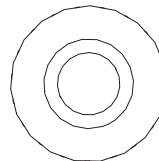

Sealing Washer (8X)



M8 x 35MM (8X)



Anti-Seize (1X)

MOUNTING BRACKETS
BRACKET PRE-ASSEMBLY (5' - 8')

0.1

Drill holes into the Service Body mounting location according to dimensions shown for 8.00 ft rack configuration. The rear drive shaft must not extend past the vehicle bumper (see offset below).

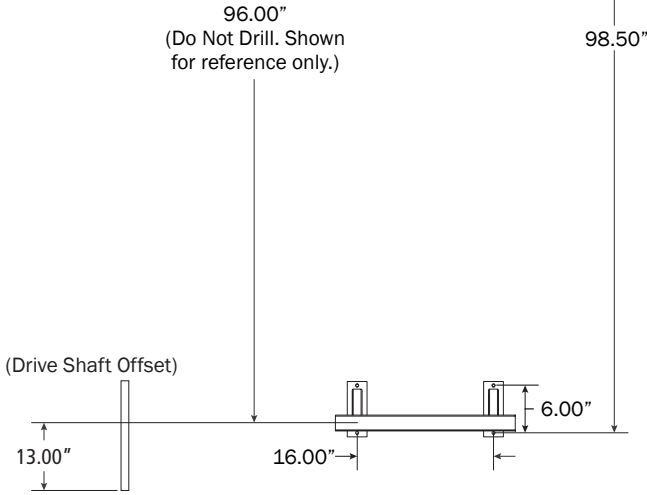

0.2

Dimensions shown below are for 5' (60.00"), 6' (72.00"), and 7' (84.00") spacing. The rear drive shaft must not extend past the vehicle bumper (see offset in Step 0.1).

Dimensions A are measured from center to center of top mounting rail. Dimensions B are measured from outside Bracket Hole to outside Bracket Hole.

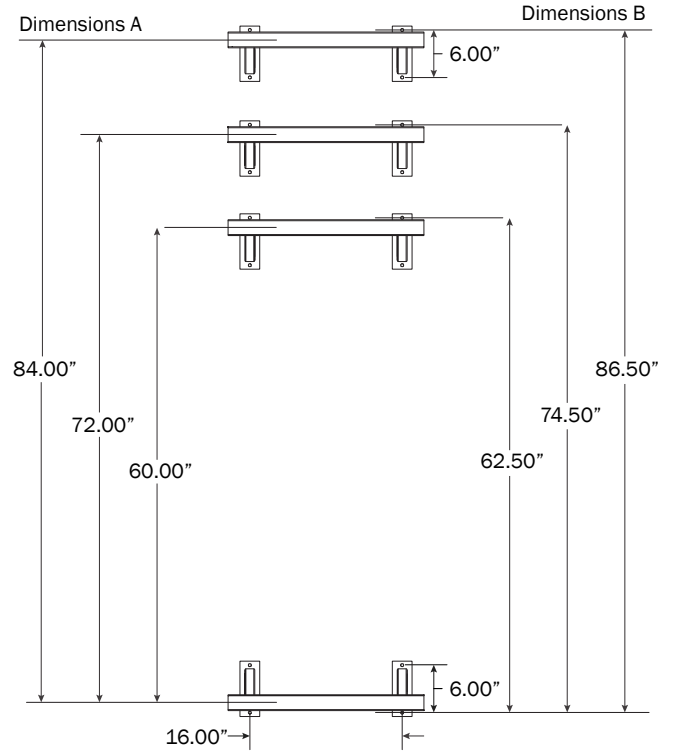

0.3

Apply Anti-Seize compound to Mounting Bracket bolts. The shorter bolt assemblies are on the outside as shown.

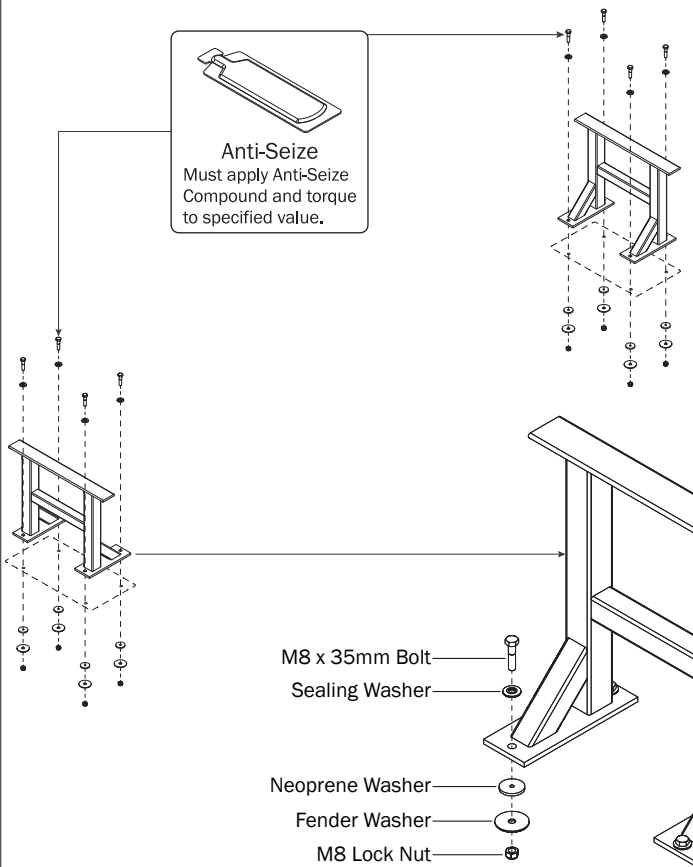

0.4

Torque all Mounting Bracket bolts to 90 in-lbs.

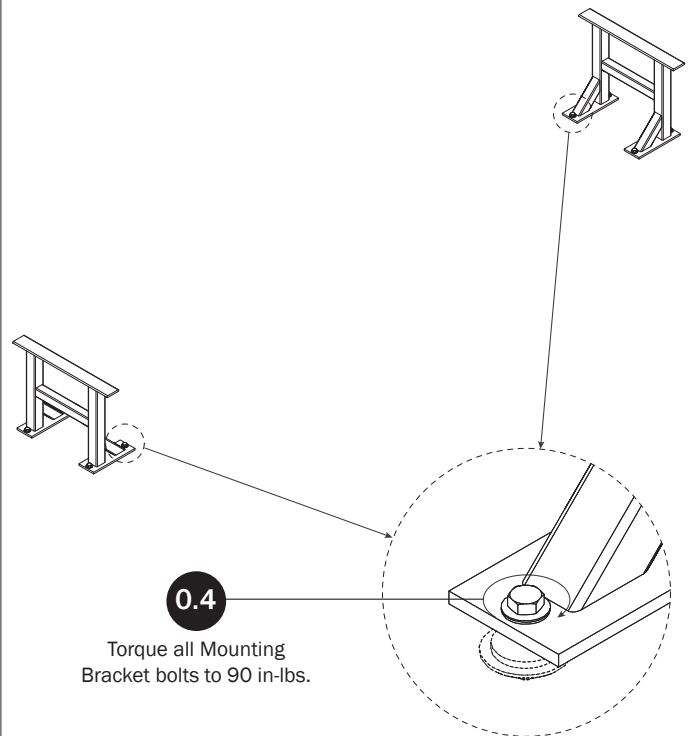

RIGHT ROTATION ASSEMBLY SEQUENCE

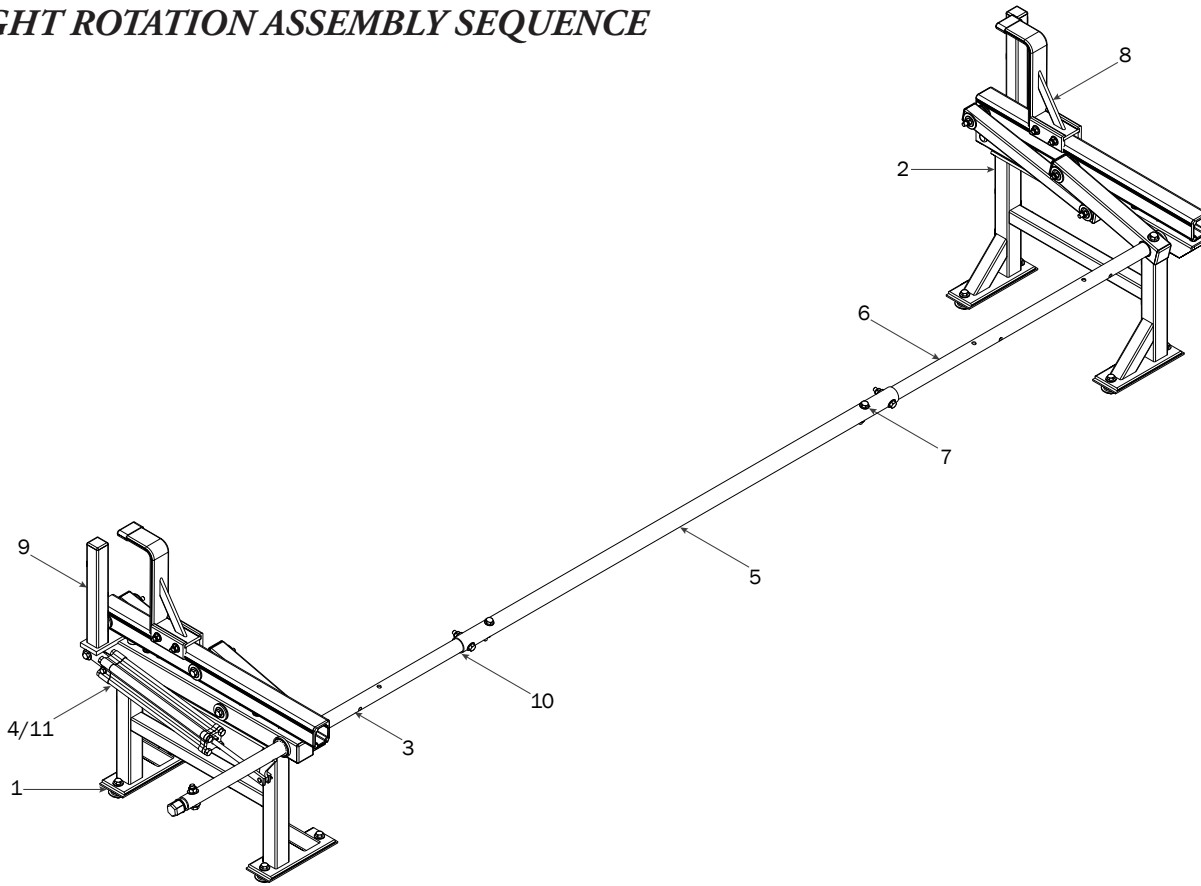

REAR ROTATION ASSEMBLY

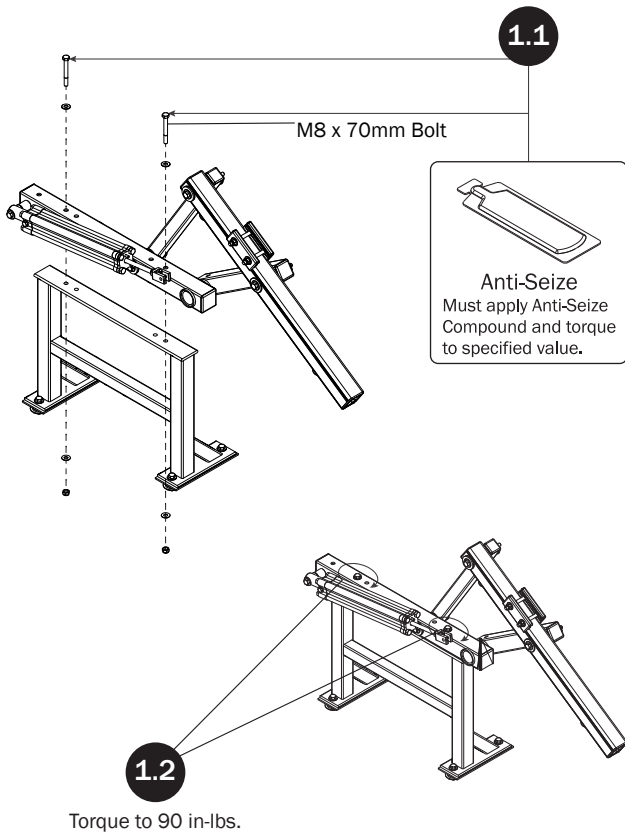

FRONT ROTATION ASSEMBLY

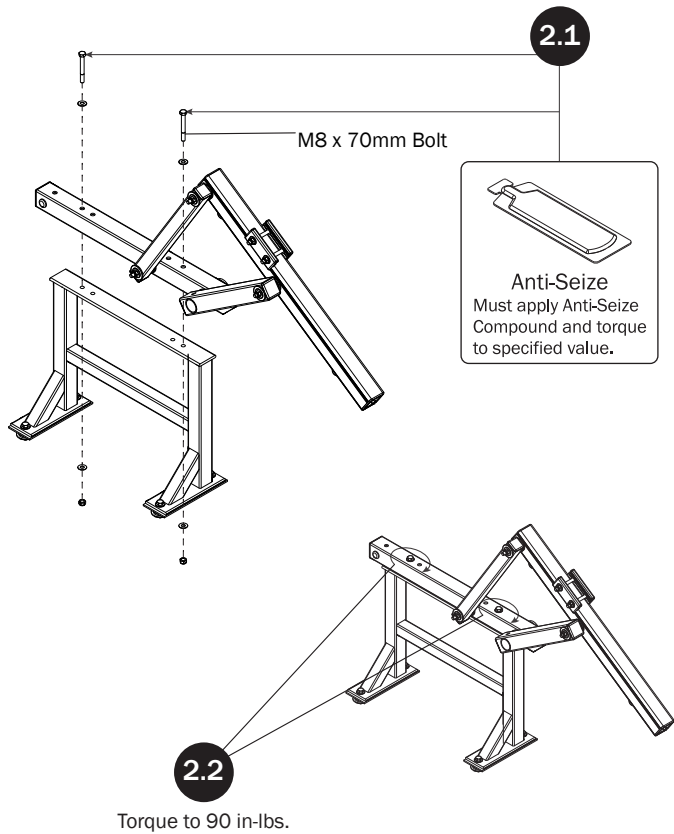

REAR DRIVE SHAFT

NOTE: For instructional clarity, the FBM Mounting System will not be shown for the remainder of this Assembly Manual.

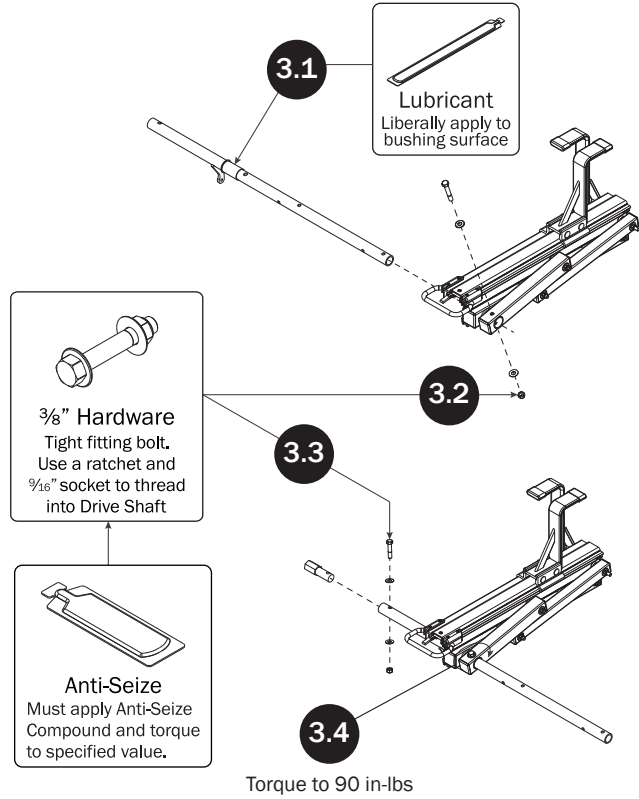

CYLINDER HARDWARE

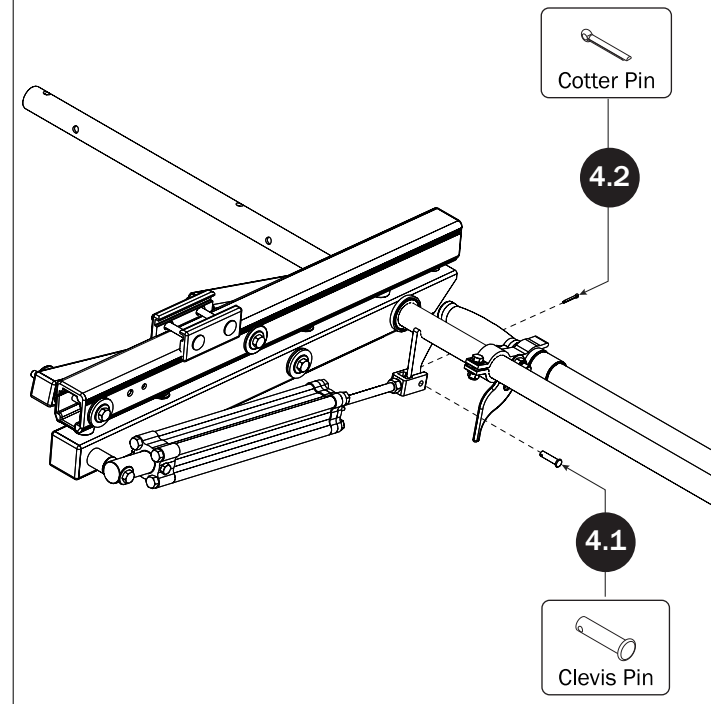

CONNECTING BAR

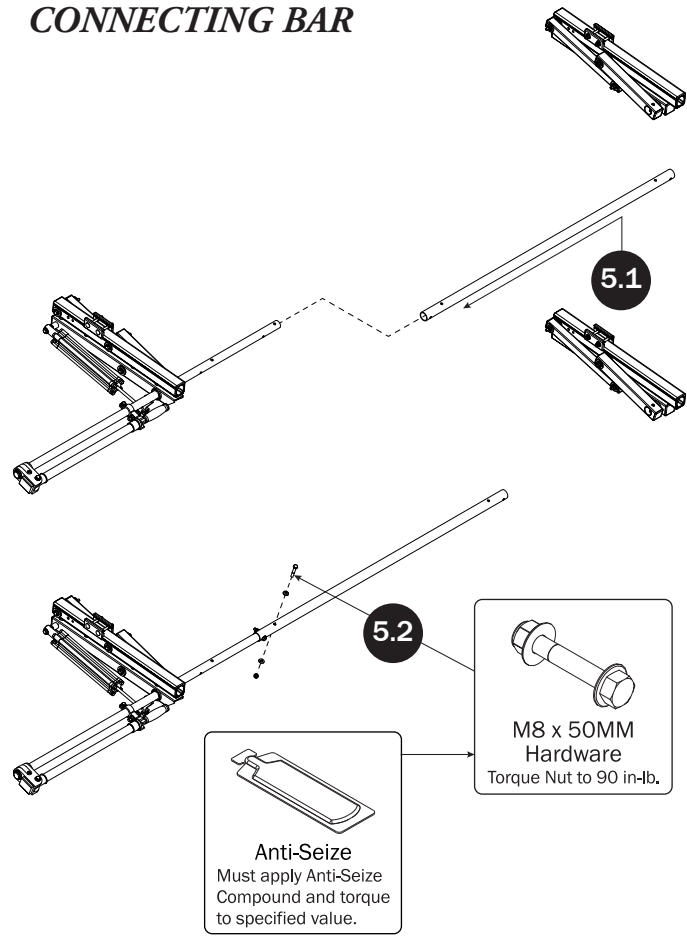

FRONT DRIVE SHAFT

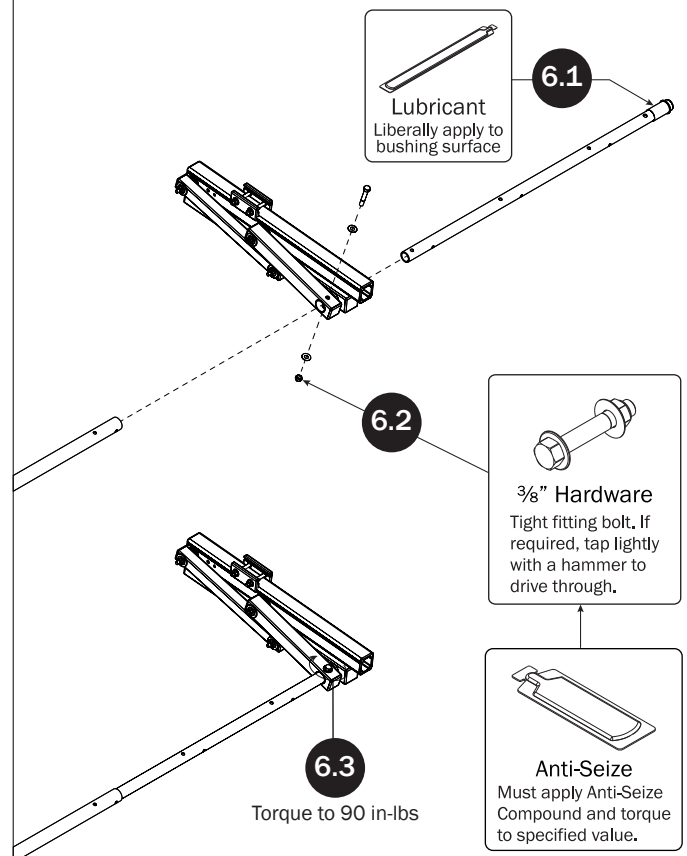

CONNECTING BAR FASTENERS

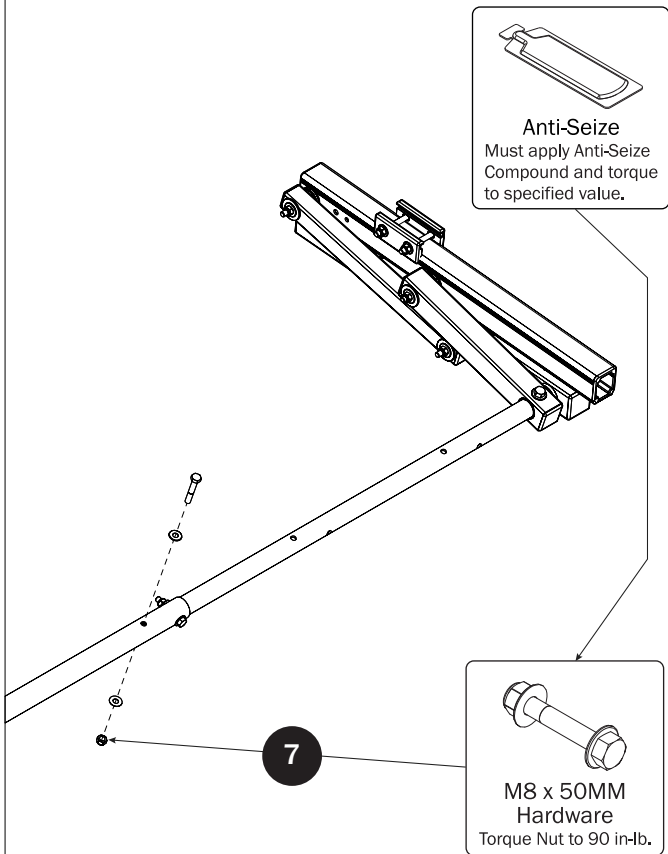

L POSTS

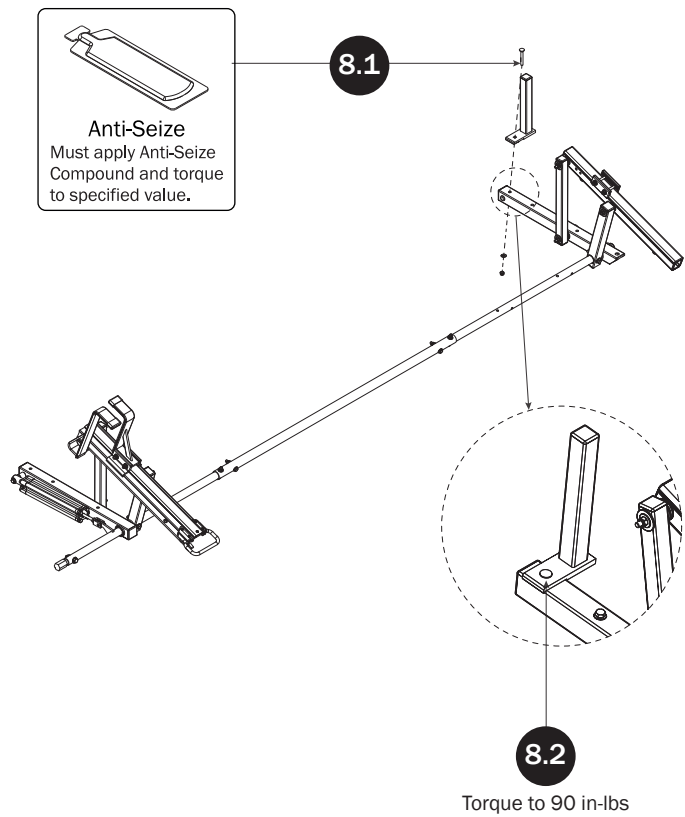

Z POSTS

SEE QUICK START GUIDE FOR ADJUSTMENTS

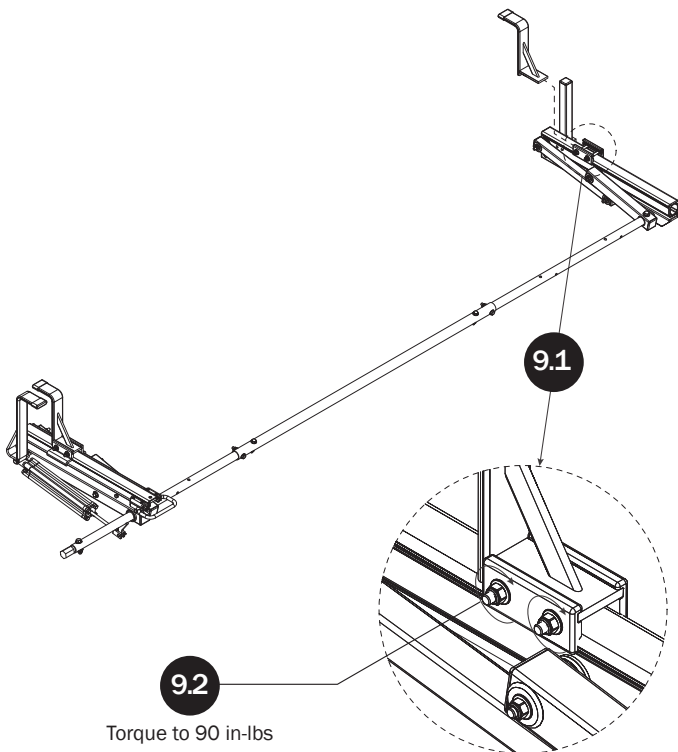

DRIVE SHAFT SEALING

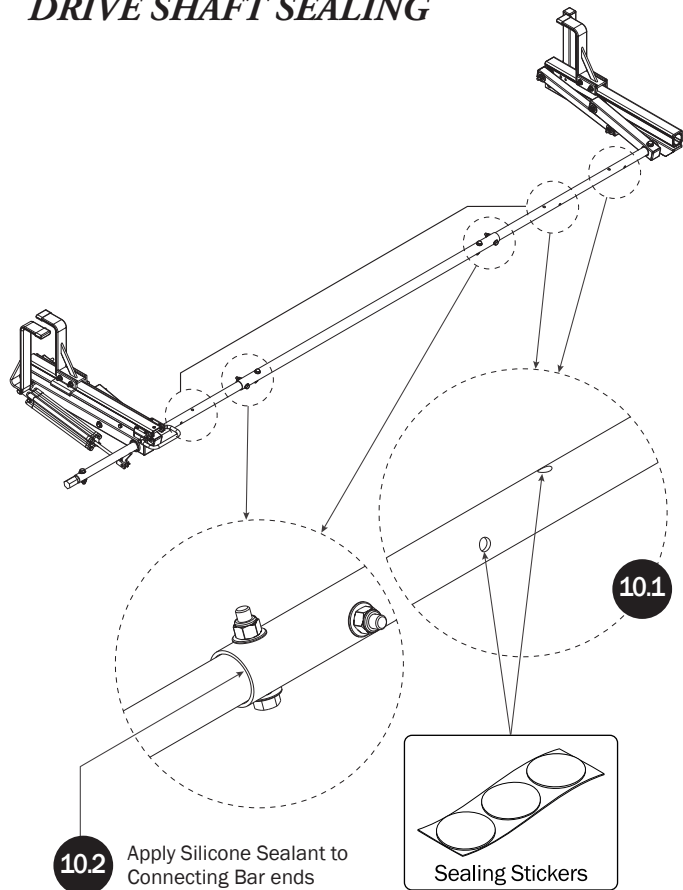

CYLINDER ADJUSTMENT

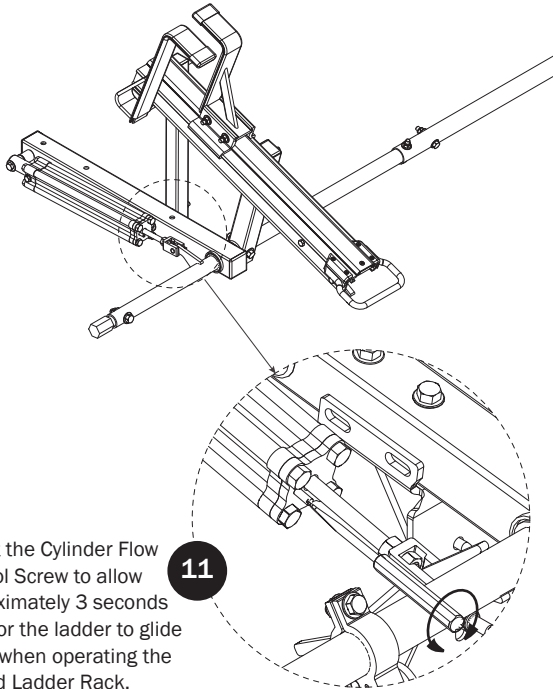

Adjust the Cylinder Flow Control Screw to allow approximately 3 seconds time for the ladder to glide down when operating the loaded Ladder Rack.

USAM-UXR0020-US01 Rev-A 0921