

PRIME DESIGN™

A Safe Fleet Brand

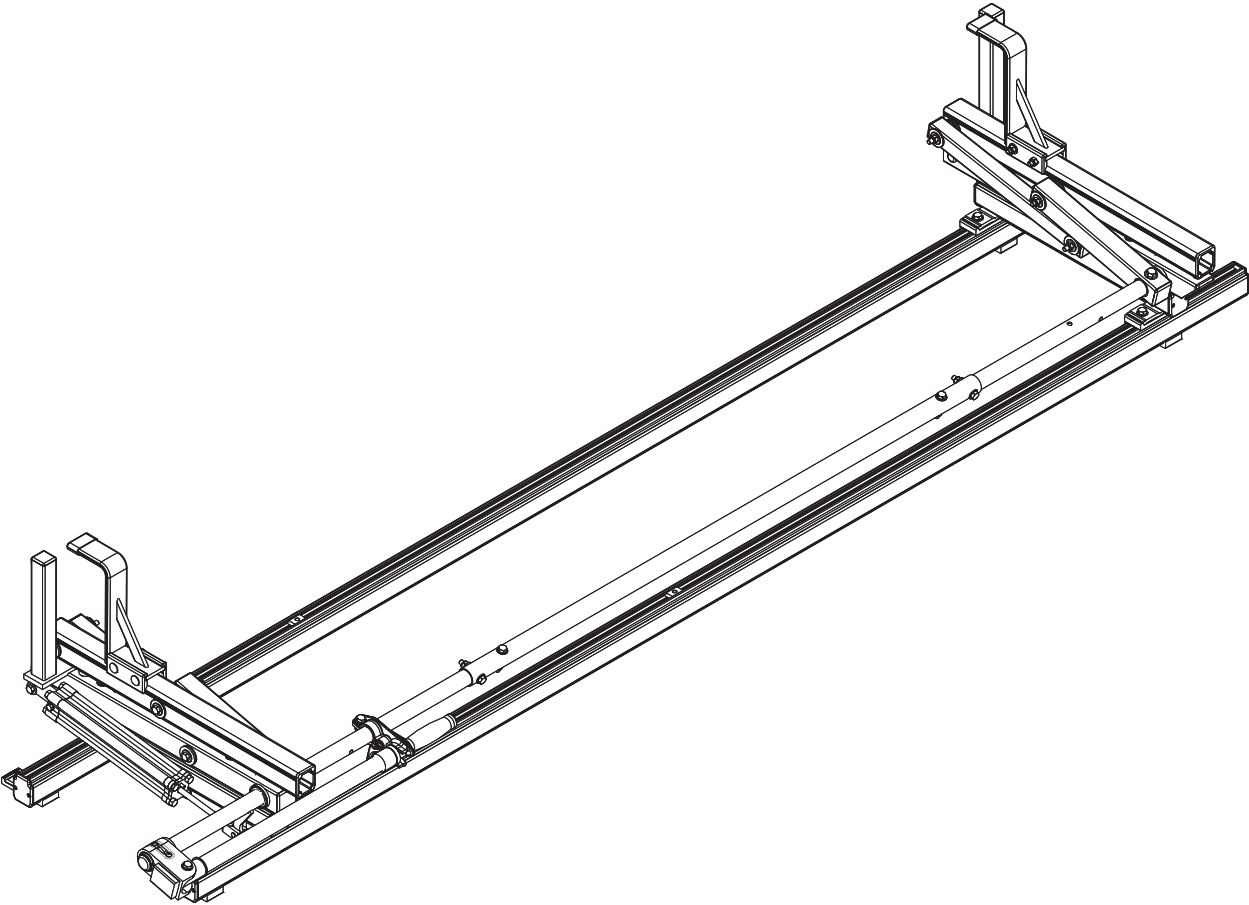

UXR
0018

CONTENTS OVERVIEW

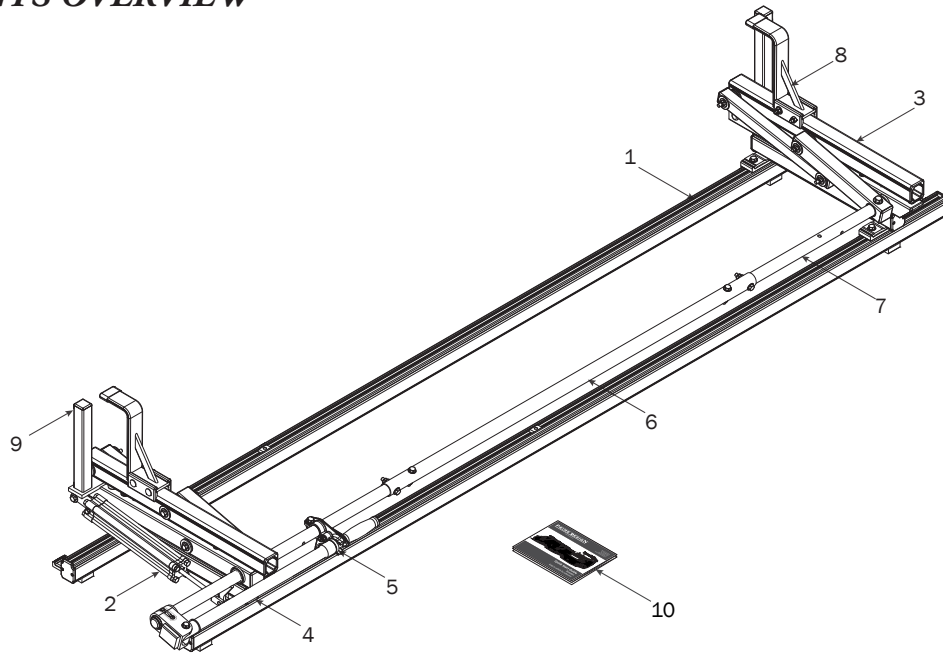

1—Mounting System (Qty 1)
98.00", with Hardware



12.00" Suspension Bar (2X)



98.00" Suspension Bar (2X)



Channel Connector Clamp (8X)



Channel Connector (8X)

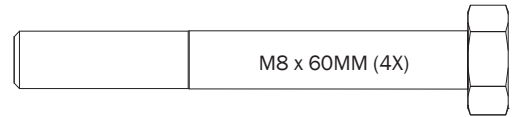

M8 x 60MM (4X)

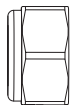

Lock Nut (4X)

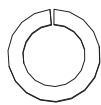

Lock Washer (8X)

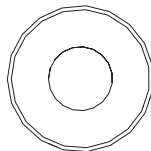

Flat Washer (20X)

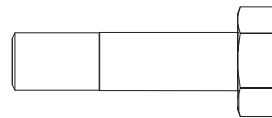

M8 x 30MM (4X)

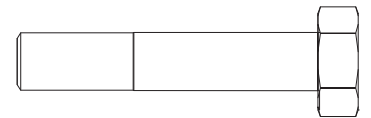

M8 x 40MM (4X)

2—Rear Rotation Assembly..... (Qty 1)

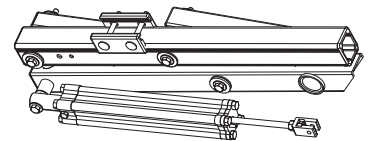

3—Front Rotation Assembly..... (Qty 1)

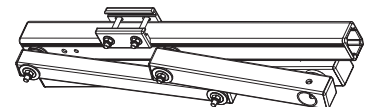

4—Rear Drive Shaft..... (Qty 1)
Right Hand, B4 Version, 34.00"

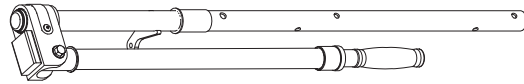

5—Handle Latch (Qty 1)
Right Hand



6—Connecting Bar..... (Qty 1)
48.00"

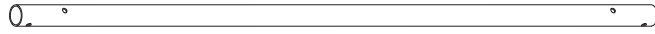

7—Front Drive Shaft (Qty 1)
B Version, 35.75"



8—Z Post (Qty 1)
Adjustable, 7.25"

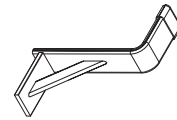

9—L Post (Qty 1)
9.25"

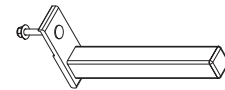

10—USQSG-Ergorack (Qty 1)
Quick Start Guide, Rotation

* Once rack installation is complete, place the Quick Start Guide into the vehicle's glove box for future ladder setup and adjustment.



11—HKT-8163 (Not called out in Overview)..... (Qty 1)



M8 x 25MM (1X)

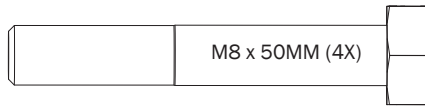

M8 x 50MM (4X)

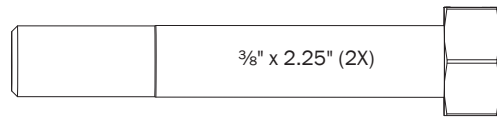

3/8" x 2.25" (2X)

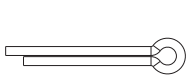

Cotter Pin (1X)



Clevis Pin (1X)

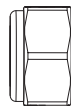

M8 Lock Nut (5X)



3/8" Lock Nut (2X)

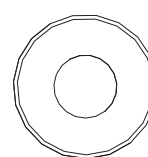

5/16" Flat Washer (10X)

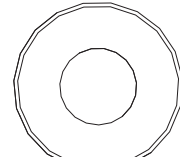

3/8" Flat Washer (4X)

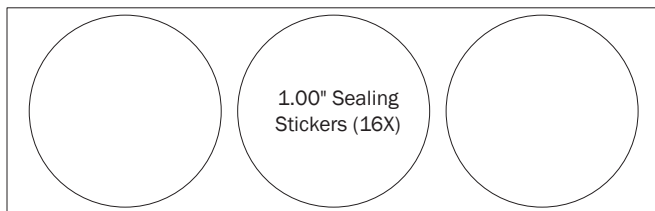

1.00" Sealing Stickers (16X)



Anti-Seize (1X)

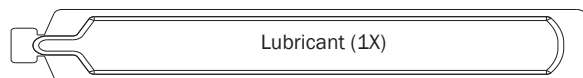

Lubricant (1X)

FBM MOUNTING

1.1 Install four Channel Connectors into the pre-installed U-Channel Mounts on your Service Body as shown. Apply Anti-Seize and finger tighten into position. Do not torque until Step 2.4.

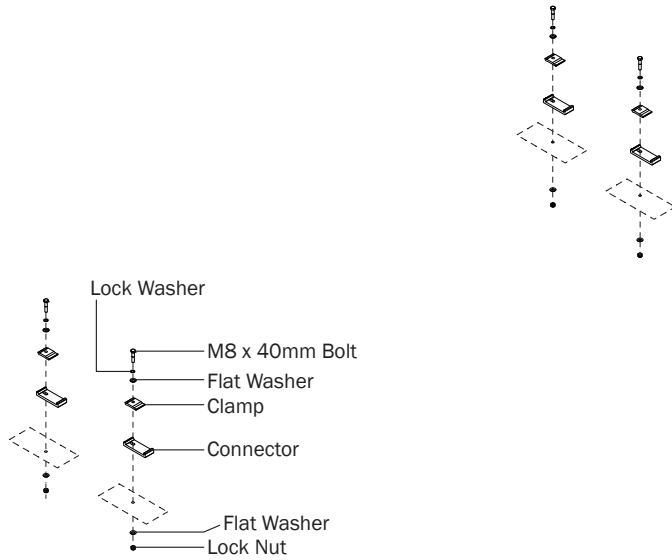

1.2 Mount the 98.00" Suspension Bars, and finger tighten into position as shown. Do not torque until Step 2.4.

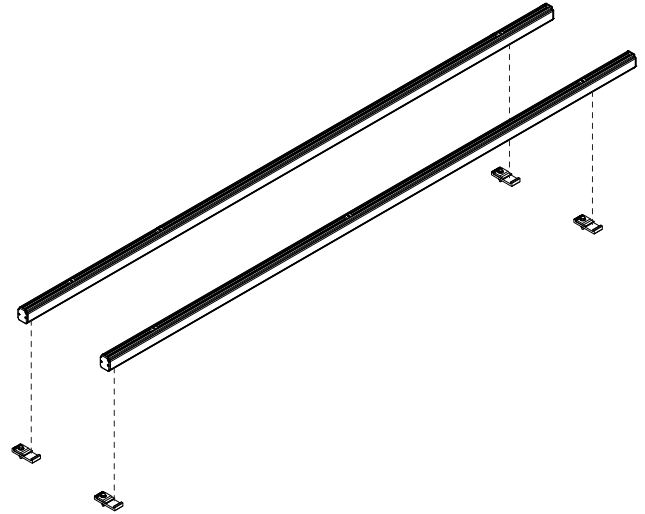

1.3 Mount the 18.00" Suspension Bars, and finger tighten into position as shown. Do not torque until Step 2.4.

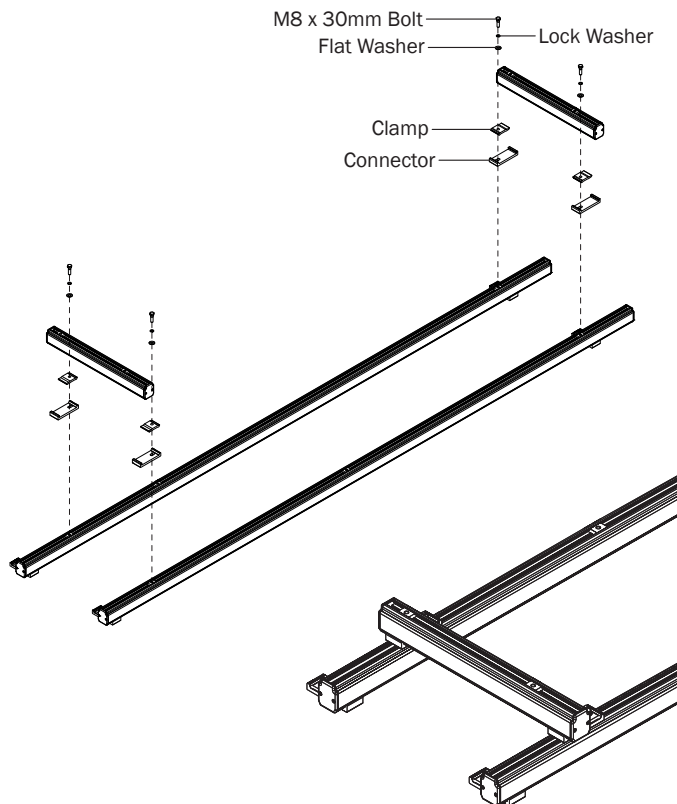

REAR ROTATION ASSEMBLY

- 2.1** Place Rear Crossbar onto FBM as shown and torque to 90 in-lbs.

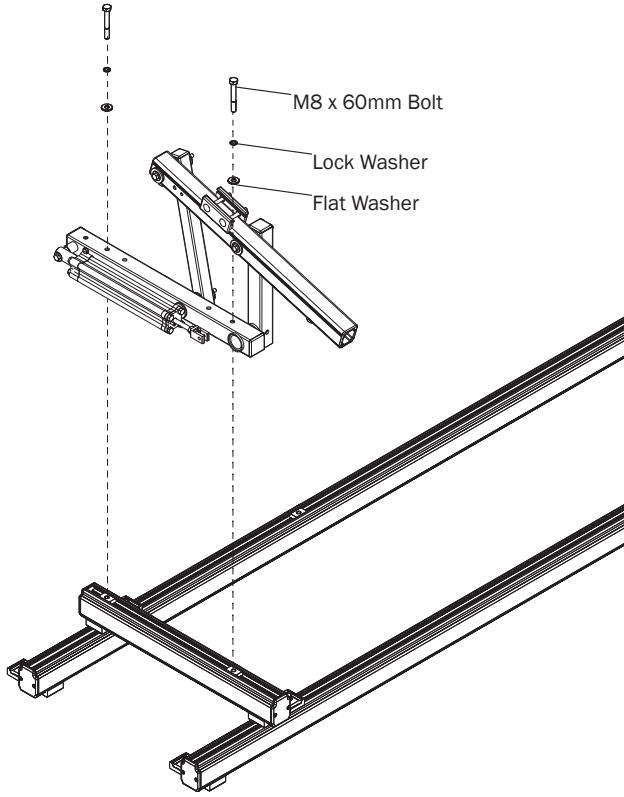

FRONT ROTATION ASSEMBLY

- 2.2** Place Front Crossbar onto FBM as shown and torque to 90 in-lbs.

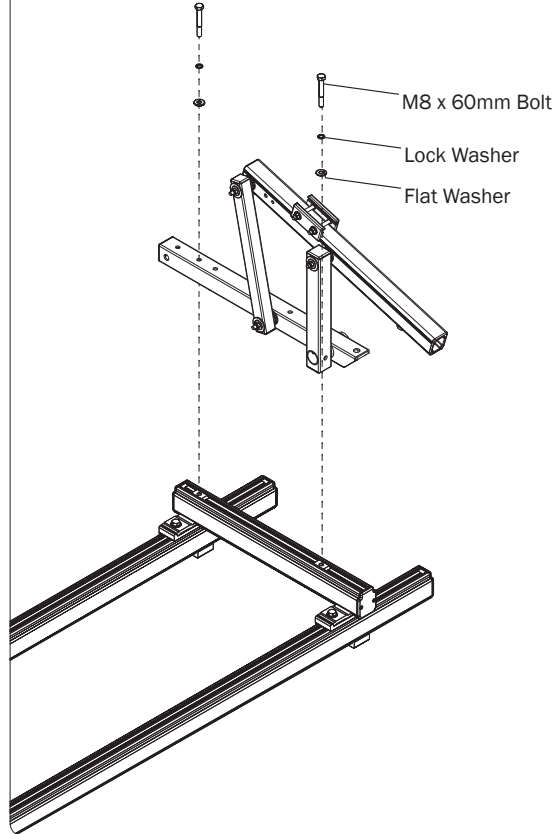

- 2.3** Rear Driveshaft offset from the center of the rear Crossbar is 11.00". Adjust Crossbars and Suspension Bars as needed to accommodate Driveshaft overhang as shown below.

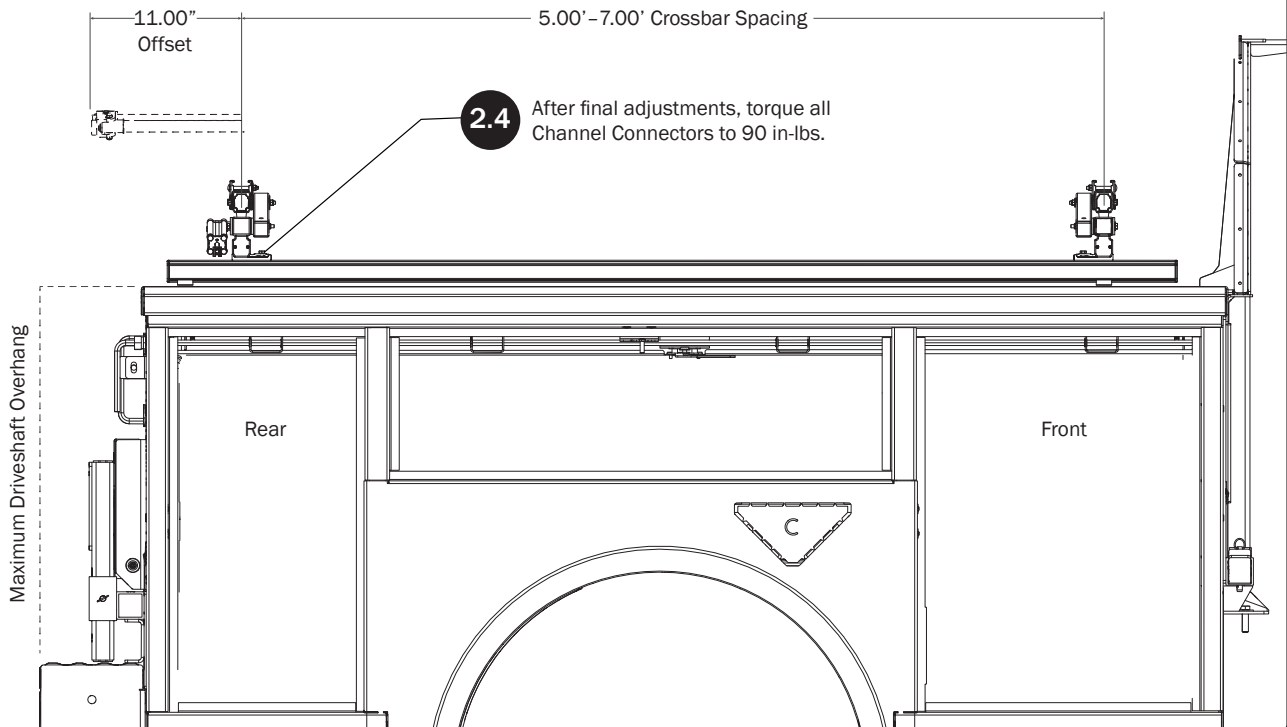

RIGHT ROTATION ASSEMBLY SEQUENCE

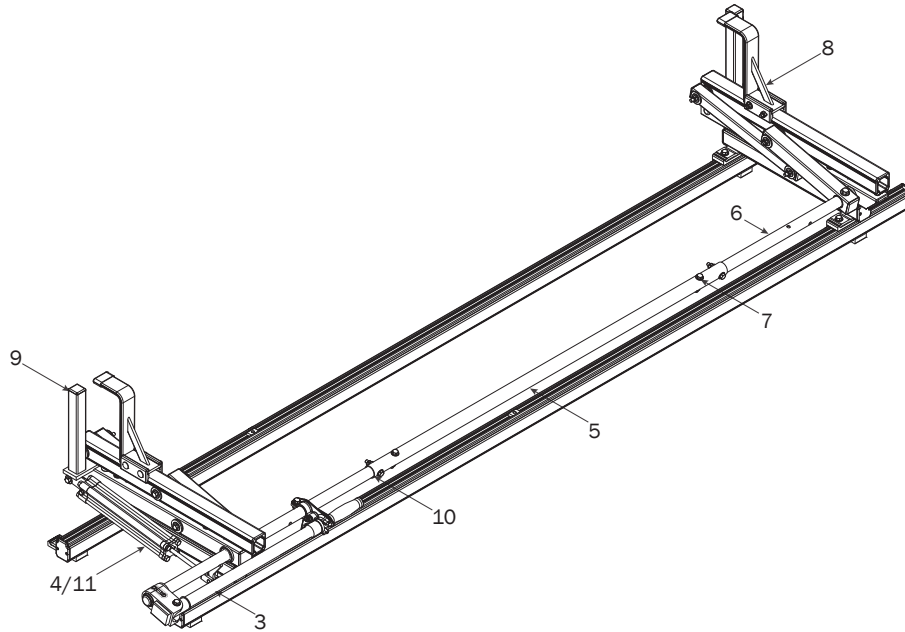

REAR DRIVE SHAFT

NOTE: For instructional clarity, the FBM Mounting System will not be shown for the remainder of this Assembly Manual.

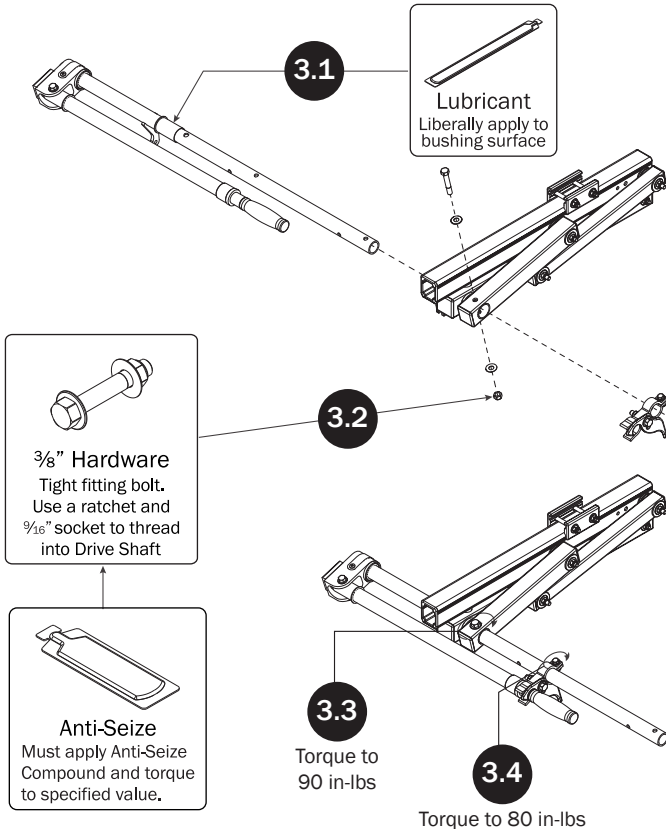

CYLINDER HARDWARE

NOTE: Loosen the Cylinder Flow Control Screw (Fig. B) as needed to allow movement for this step sequence.

When finished with Cylinder Hardware, tighten the Flow control Screw all the way closed then turn back open 1 1/2 turn.

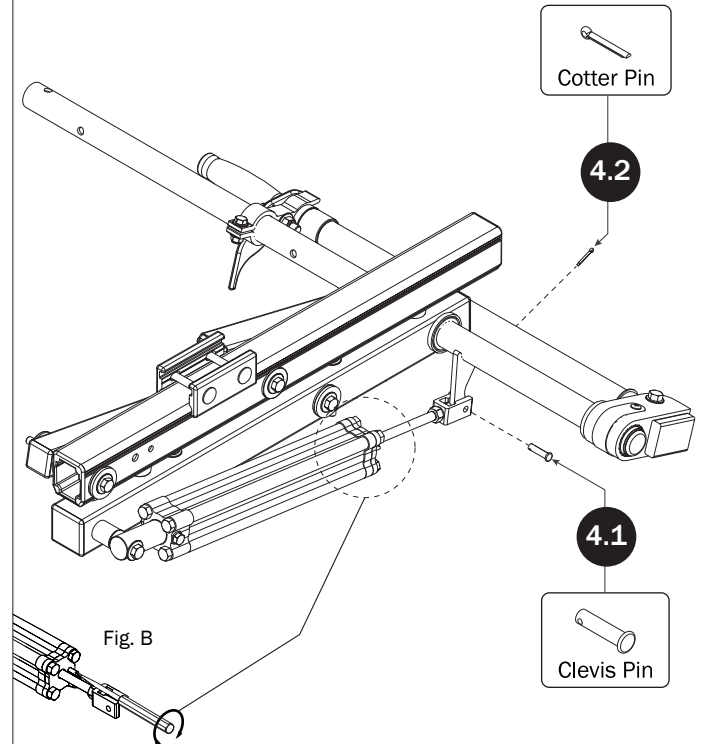

CONNECTING BAR

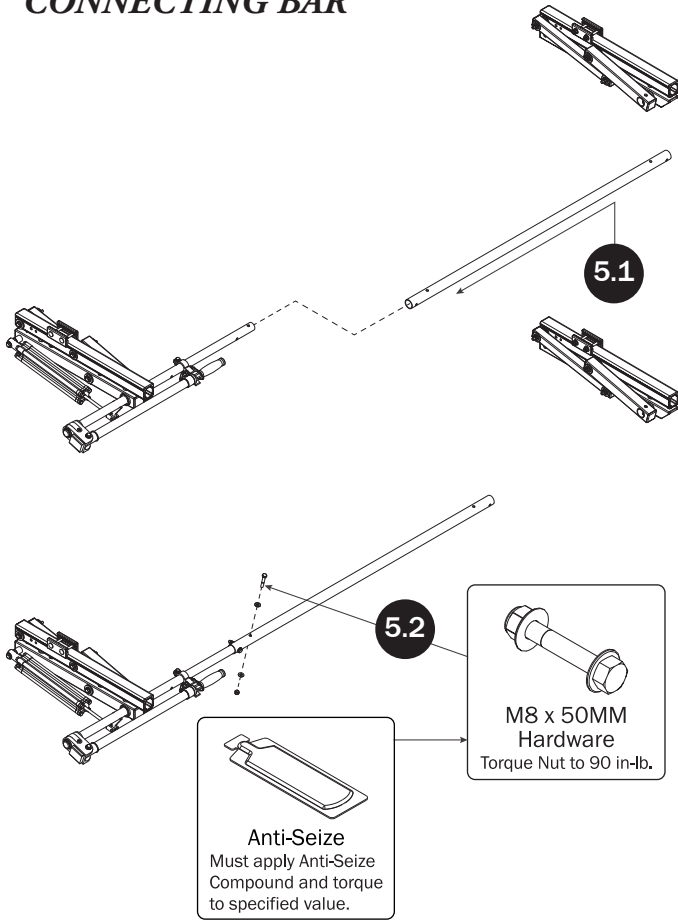

FRONT DRIVE SHAFT

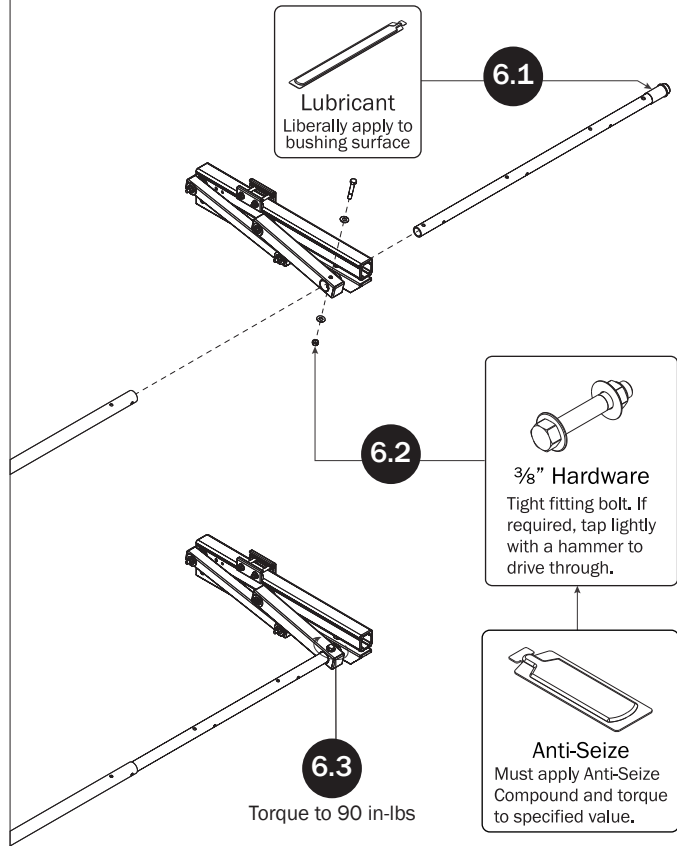

CONNECTING BAR FASTENERS

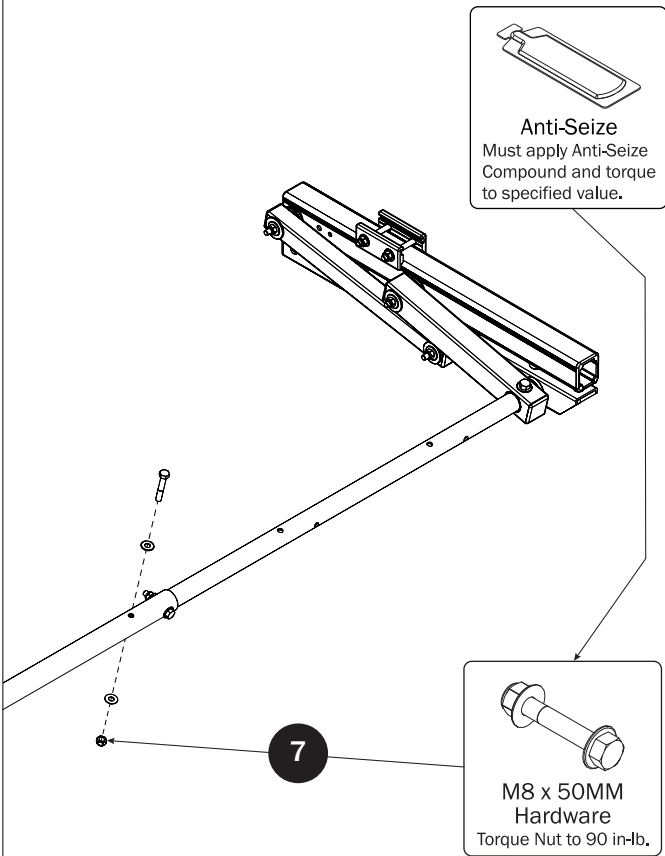

L POSTS

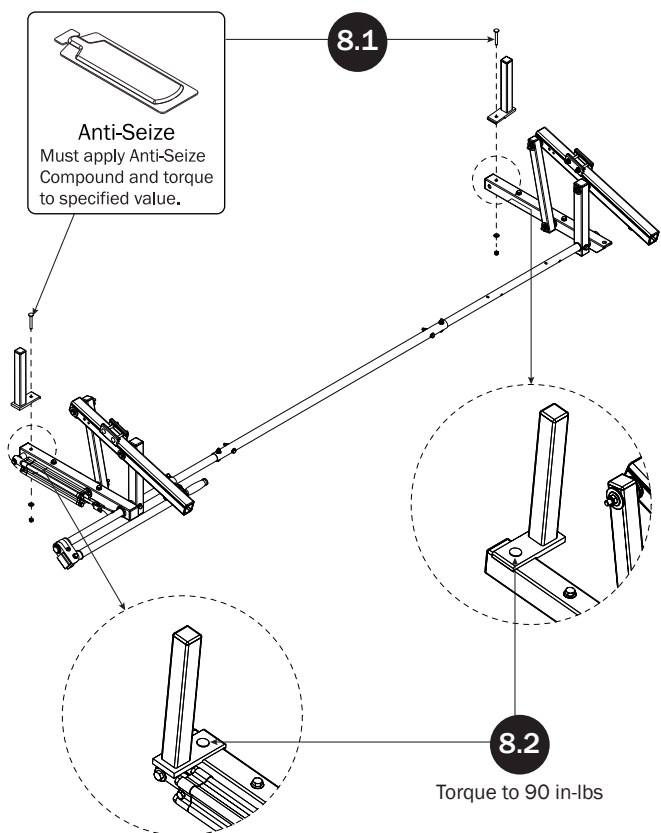

Z POSTS

SEE QUICK START GUIDE FOR ADJUSTMENTS

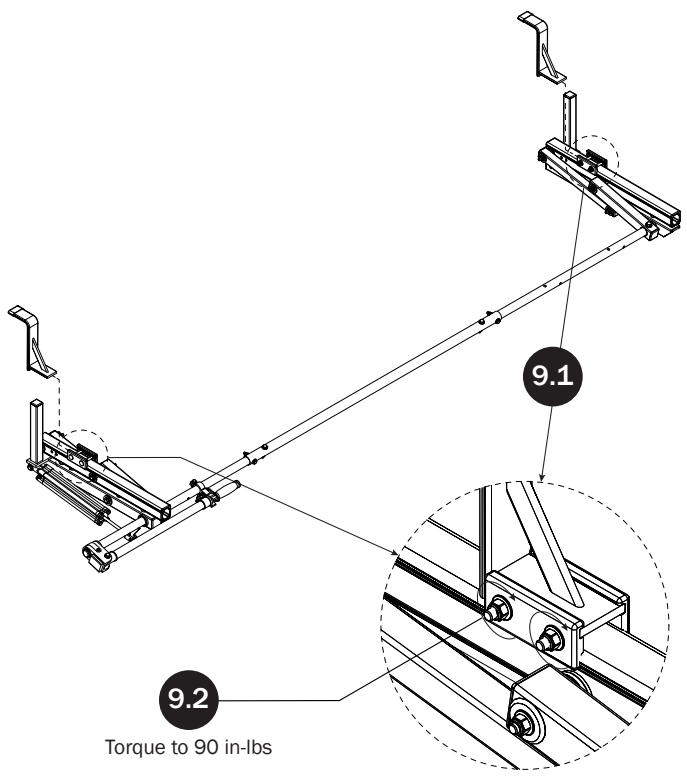

9.2

Torque to 90 in-lbs

9.1

DRIVE SHAFT SEALING

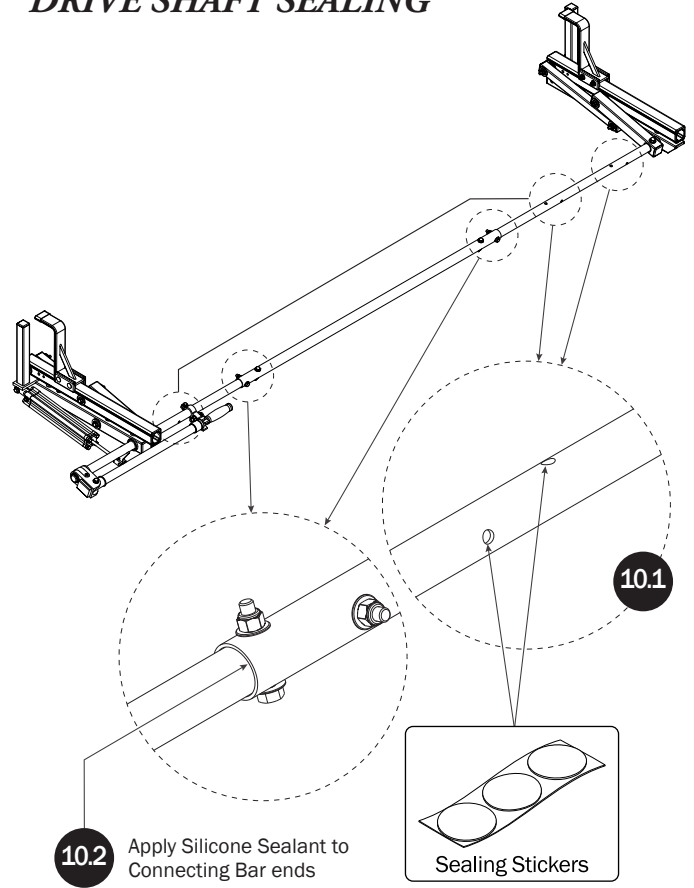

10.2

Apply Silicone Sealant to Connecting Bar ends

10.1

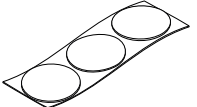

Sealing Stickers

CYLINDER ADJUSTMENT

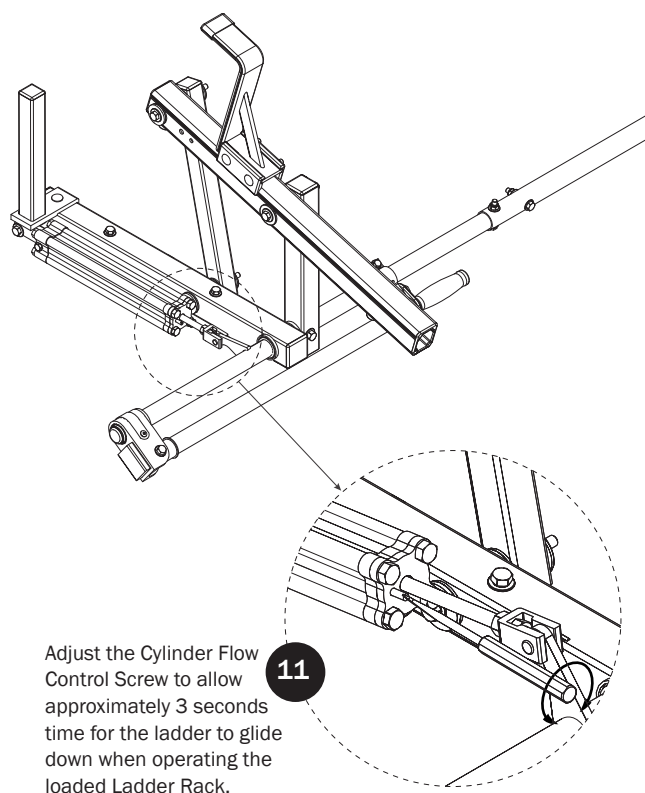

11

Adjust the Cylinder Flow Control Screw to allow approximately 3 seconds time for the ladder to glide down when operating the loaded Ladder Rack.

QUICK START GUIDE

12

Place the Quick Start Guide into the vehicle's glove box for ladder setup and adjustment.

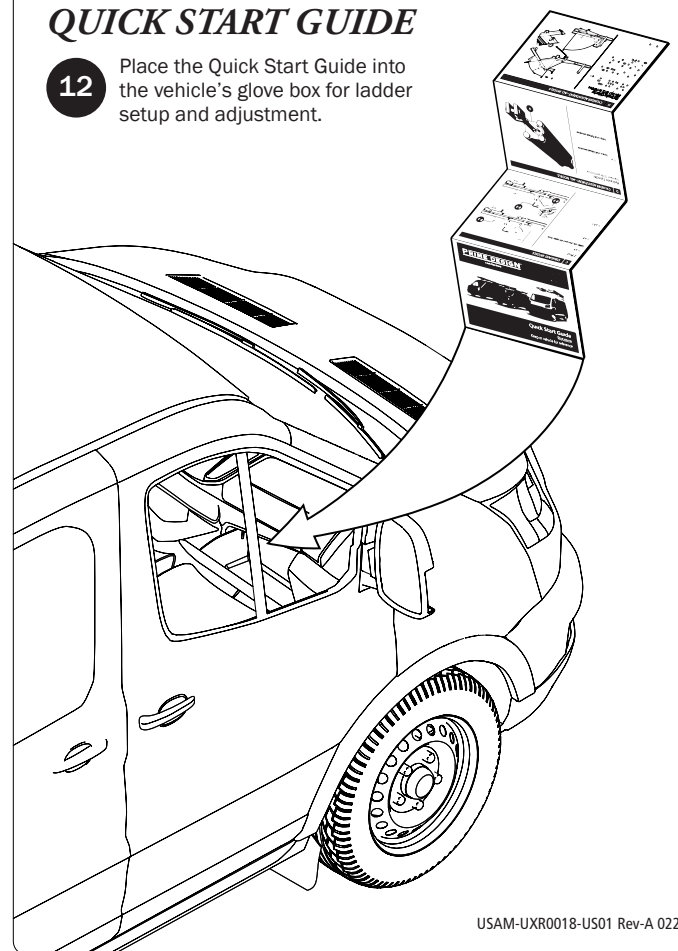

USAM-UXR0018-US01 Rev-A 0220