

# PRIME DESIGN™

A Safe Fleet Brand

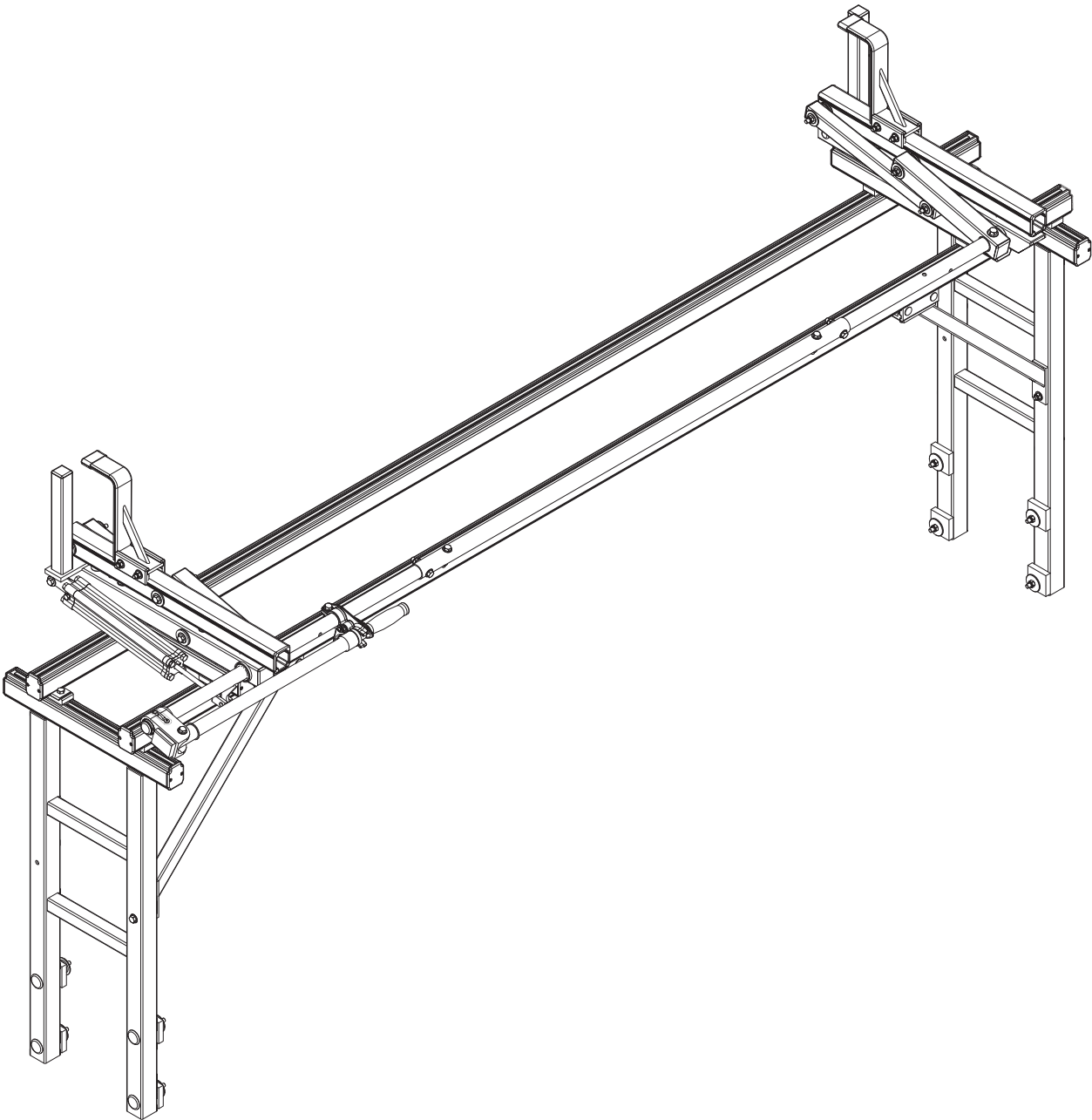

**UXR**  
**0015**

PRIME DESIGN, A SAFE FLEET BRAND

Address: 580 Opperman Drive, Eagan, MN 55123 • Toll Free: 1.8.PRIME.RACK  
Fax: 651-552-1799 • Email: [info@primedesign.net](mailto:info@primedesign.net) • Website: [www.primedesign.net](http://www.primedesign.net)

CONTENTS OVERVIEW

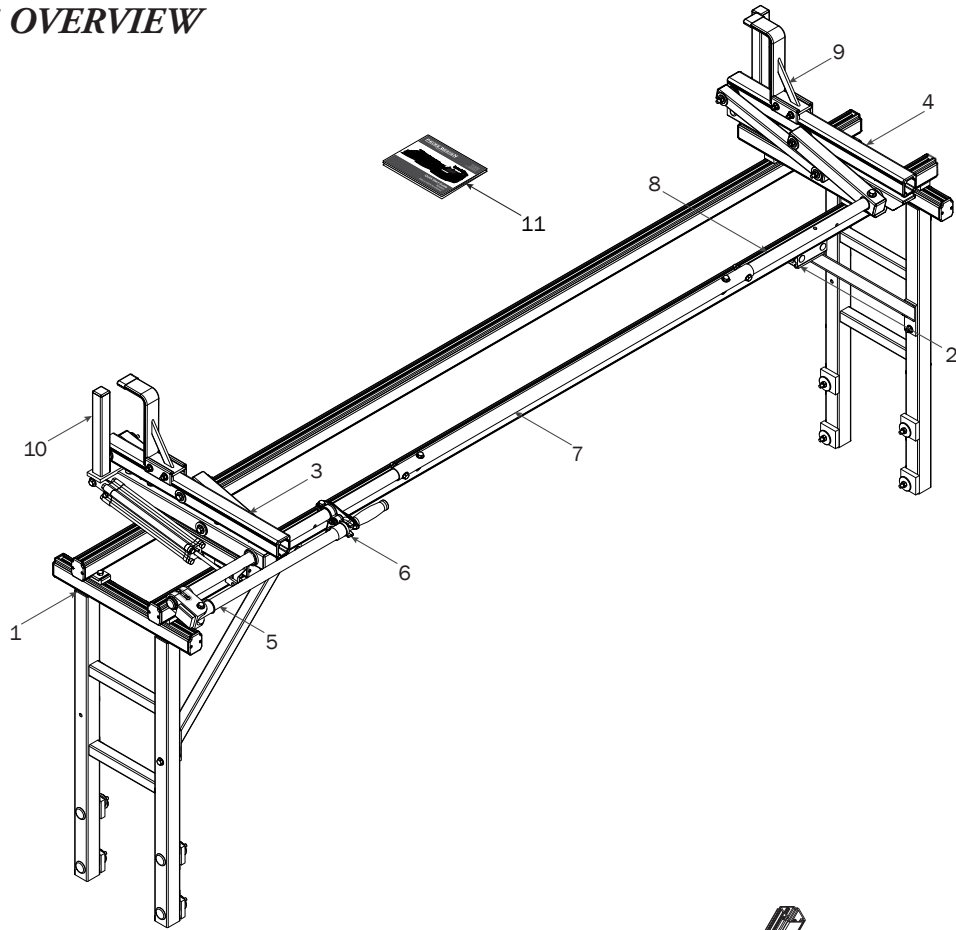

1—FBM-0041 ..... (Qty 1)  
98.00", Suspension Bar Frame, with Hardware

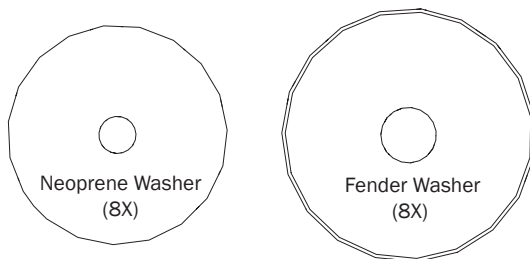
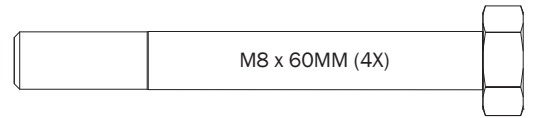
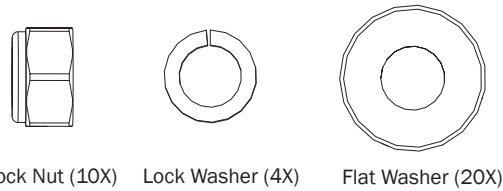
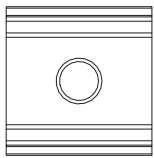
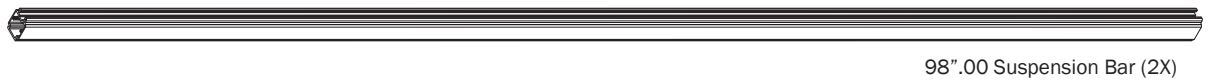
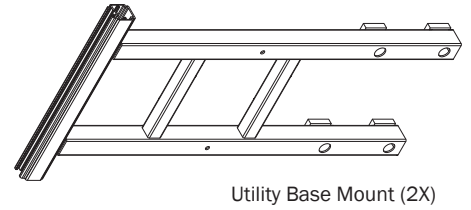
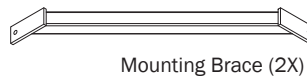

2—WorkPro Light Mount ..... (Qty 1)  
Below Crossbar with Hardware



Bottom Connector (1X)



Clamp Connector Pair (1X)

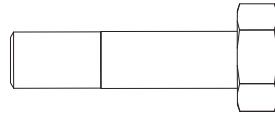

M8 x 25 MM (1X)



M8 x 60MM (2X)

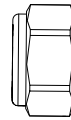

M8 Lock Nut (3X)

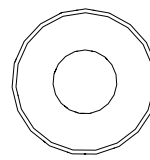

5/16" Flat Washer (3X)

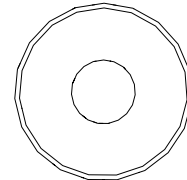

Nylon Washer (1X)

3—Rear Rotation Assembly..... (Qty 1)

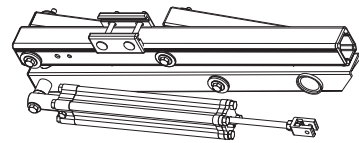

4—Front Rotation Assembly..... (Qty 1)

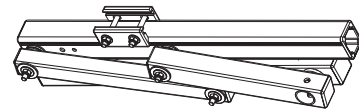

5—Rear Drive Shaft..... (Qty 1)  
Right Hand, B4 Version, 34.00"

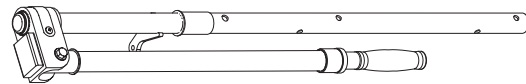

6—Handle Latch ..... (Qty 1)  
Right Hand



7—Connecting Bar..... (Qty 1)  
48.00"



8—Front Drive Shaft..... (Qty 1)  
B Version, 35.75"



9—Z Post ..... (Qty 1)  
Adjustable, 7.25"

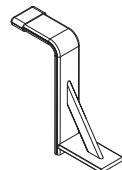

10—L Post ..... (Qty 1)  
9.25"

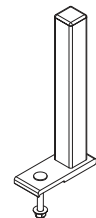

11—USQSG-Ergorack ..... (Qty 1)  
Quick Start Guide, Rotation

\* Once rack installation is complete, place the Quick Start Guide into the vehicle's glove box for future ladder setup and adjustment.

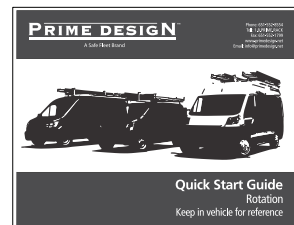

11—HKT-8163 (Not called out in Overview)..... (Qty 1)

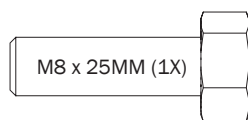

M8 x 25MM (1X)

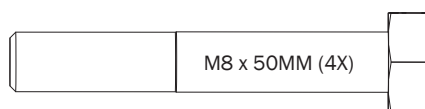

M8 x 50MM (4X)

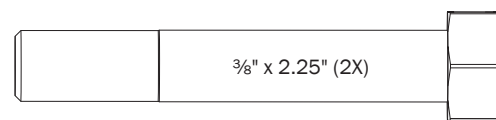

3/8" x 2.25" (2X)



Cotter Pin (1X)

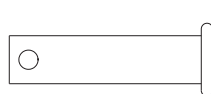

Clevis Pin (1X)



M8 Lock Nut (5X)



3/8" Lock Nut (2X)

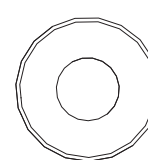

1/16" Flat Washer (10X)

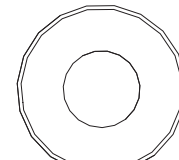

3/8" Flat Washer (4X)

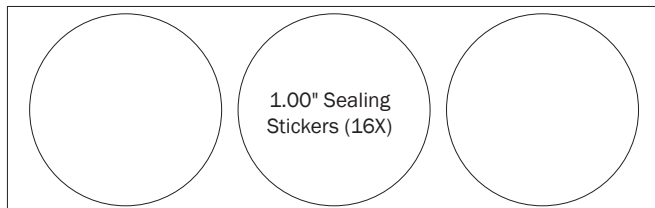

1.00" Sealing Stickers (16X)



Anti-Seize (1X)

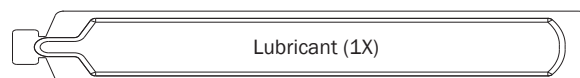

Lubricant (1X)

# FBM MOUNTING

0.1

Drill holes into the Service Body mounting location according to dimensions shown for 7.00 ft rack configuration. The rear drive shaft must not extend past the vehicle bumper. (See offset below)

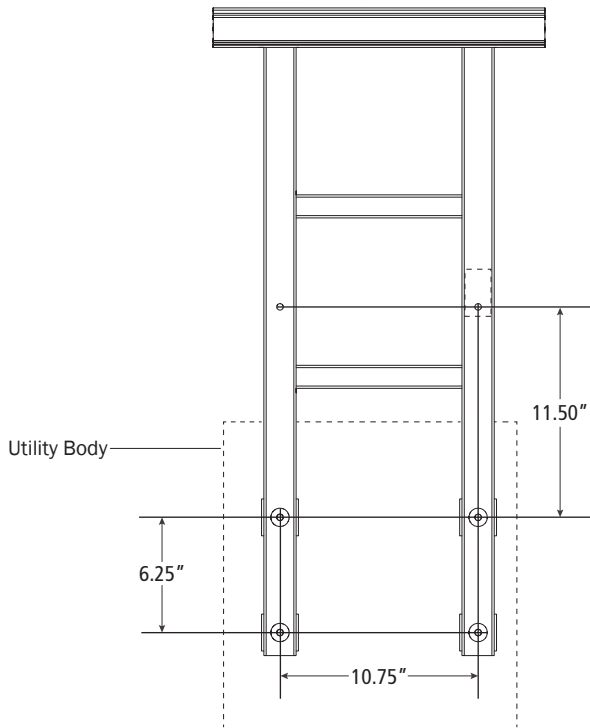

Utility Body

Front

98.00"

Rear

9.00" (Drive Shaft Offset-Max)

0.2

Install Mounts to Utility Body and tighten Bolt Assemblies to 90 in-lbs. Insert the Round Caps from HKT-0150 into the bolt holes.

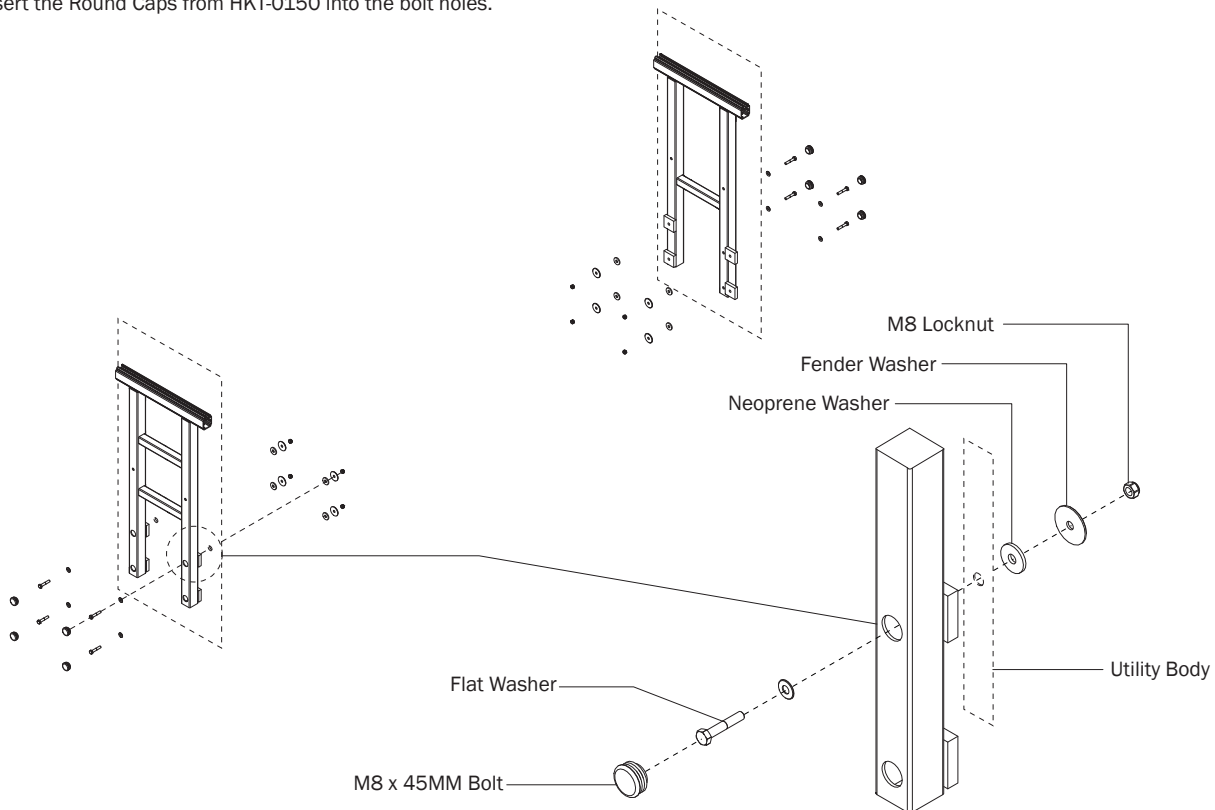

**0.3** Install Channel Connectors and End Caps as shown.

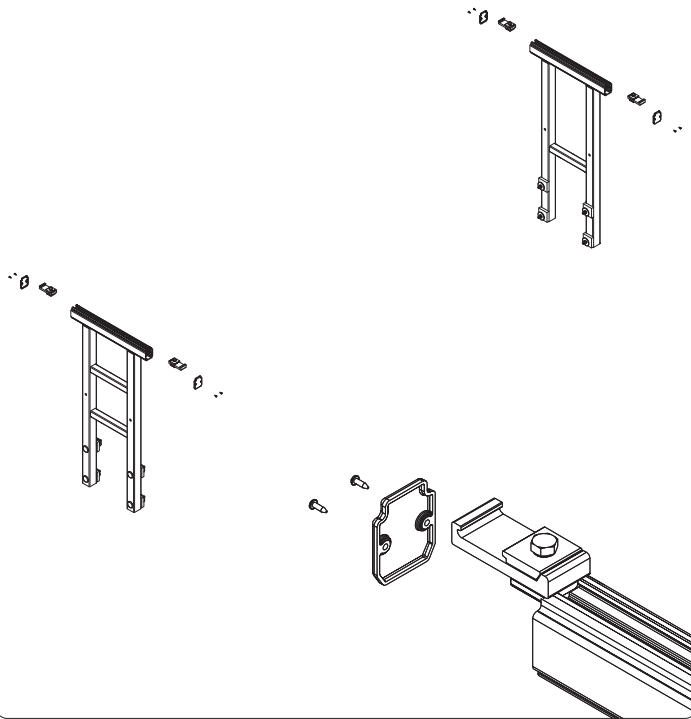

**0.4** Mount the 98.00" Suspension Bars, and finger tighten into position as shown.

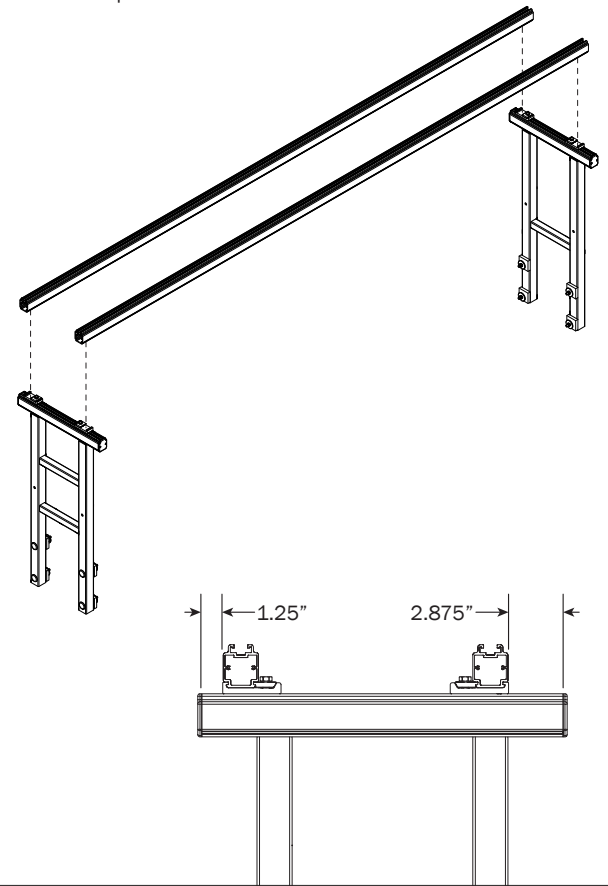

**0.5** Assemble the WorkPro Clamp onto the Mounting Brace as shown and finger-tighten only.

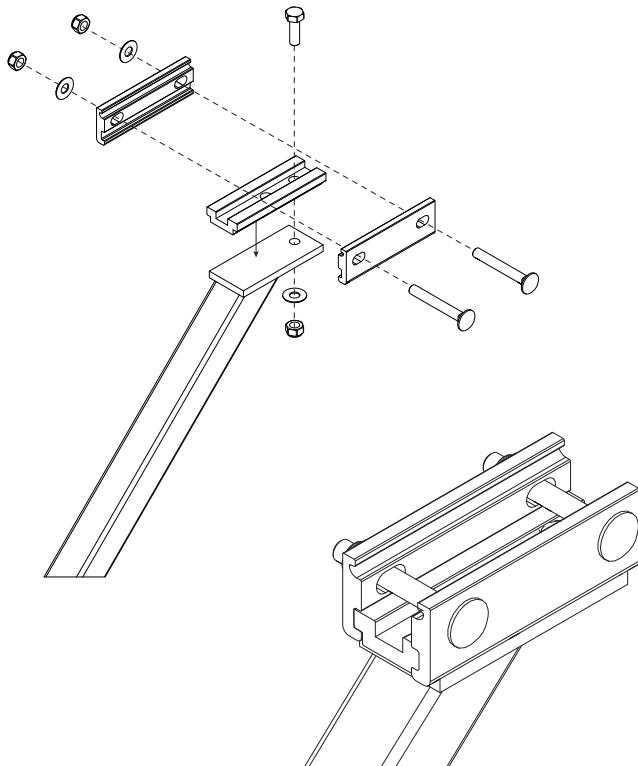

**0.6** Mount the Brace as shown below and tighten clamp nuts to 90 in-lbs. Repeat Steps 0.5-0.6 for the front end.

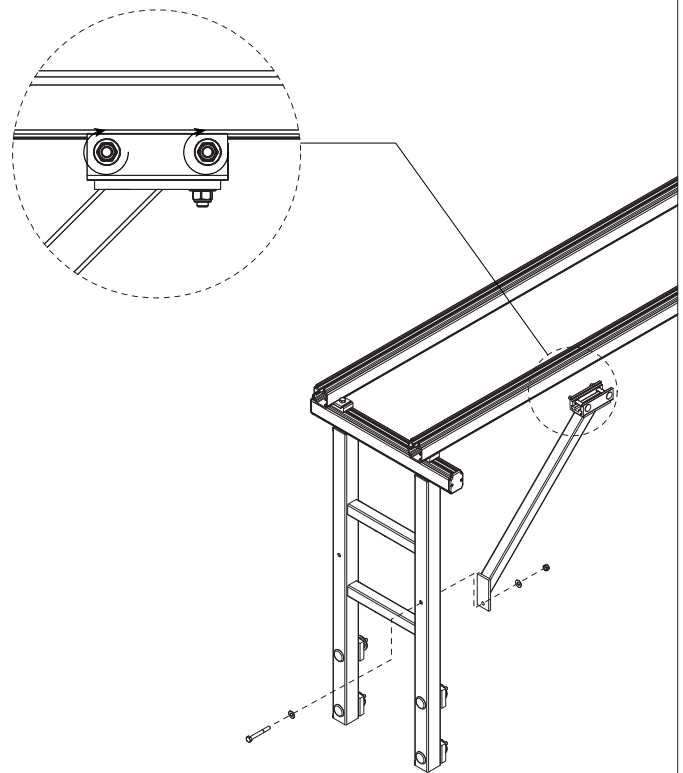

**0.7** Install Channel Connectors and End Caps as shown

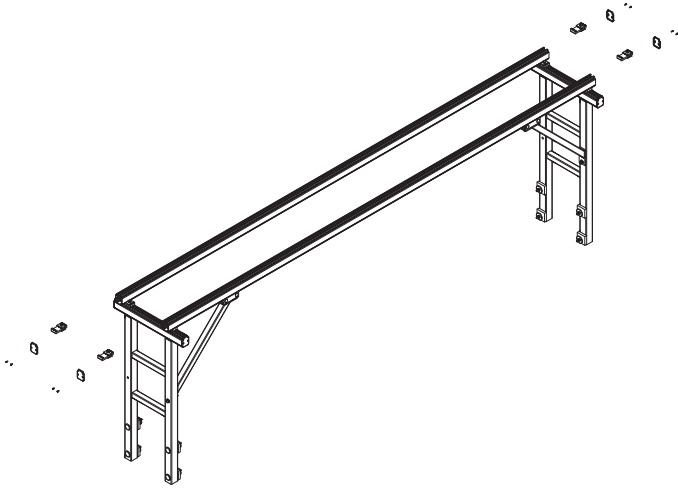

**0.8** Mount the final 18.00" Suspension Bars as shown

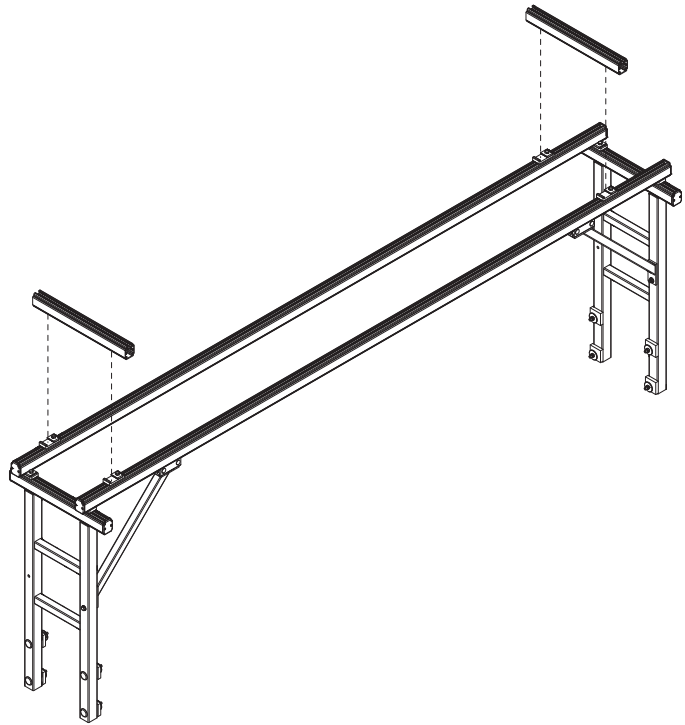

**0.9** Install Strip Nuts and End Caps as shown

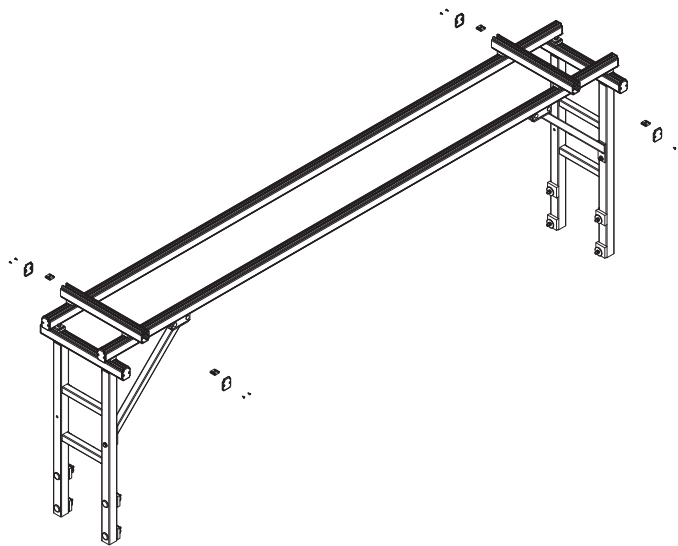

**0.10** Position all Brackets on Suspension Bars as shown below for 7.00' (84.00"). Tighten all Bracket nuts to 90 in-lbs.

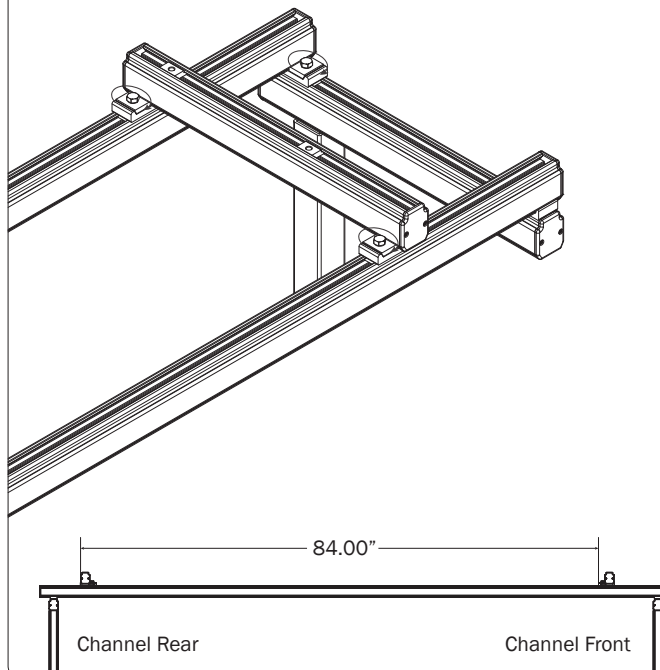

**RIGHT ROTATION ASSEMBLY SEQUENCE**

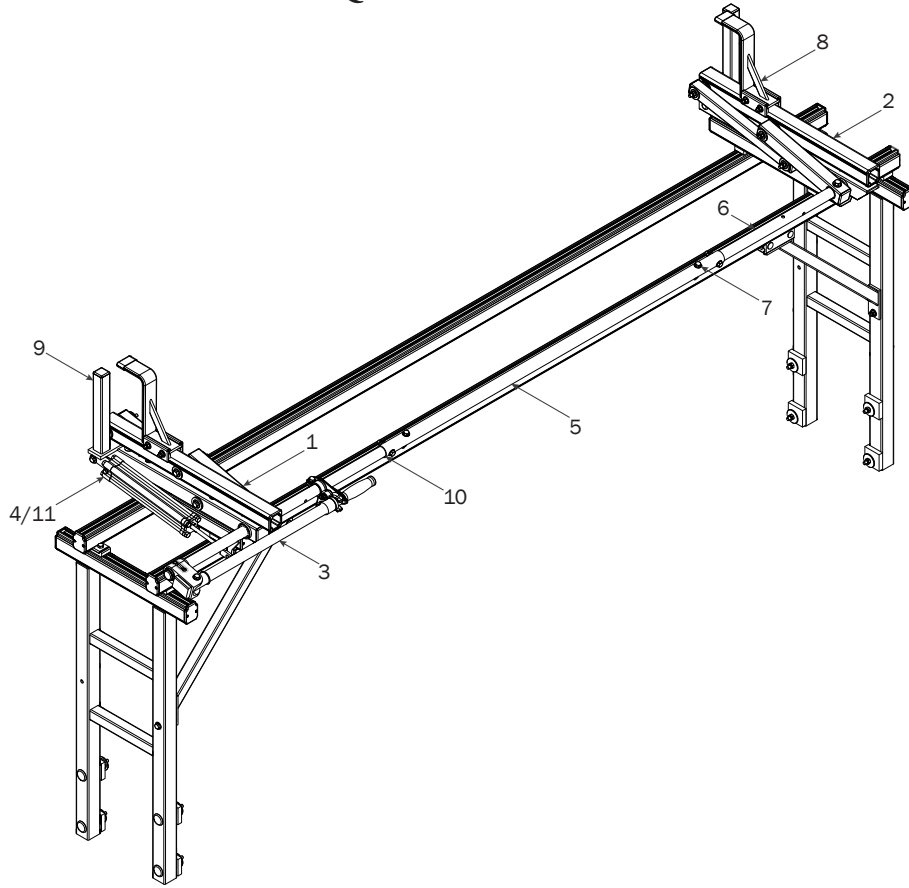

**REAR ROTATION ASSEMBLY**

- 1 Place Rear Crossbar onto FBM as shown and torque to 90 in-lbs.

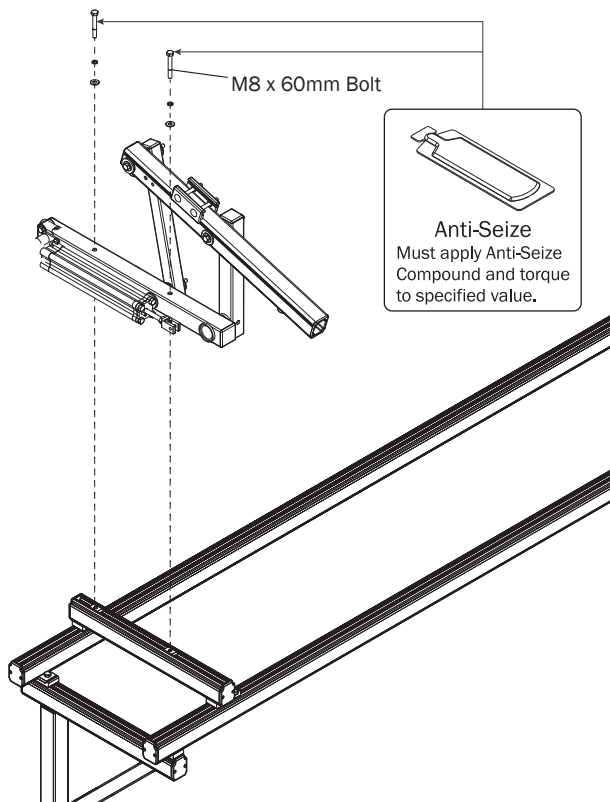

**FRONT ROTATION ASSEMBLY**

- 2 Place Front Crossbar onto FBM as shown and torque to 90 in-lbs.

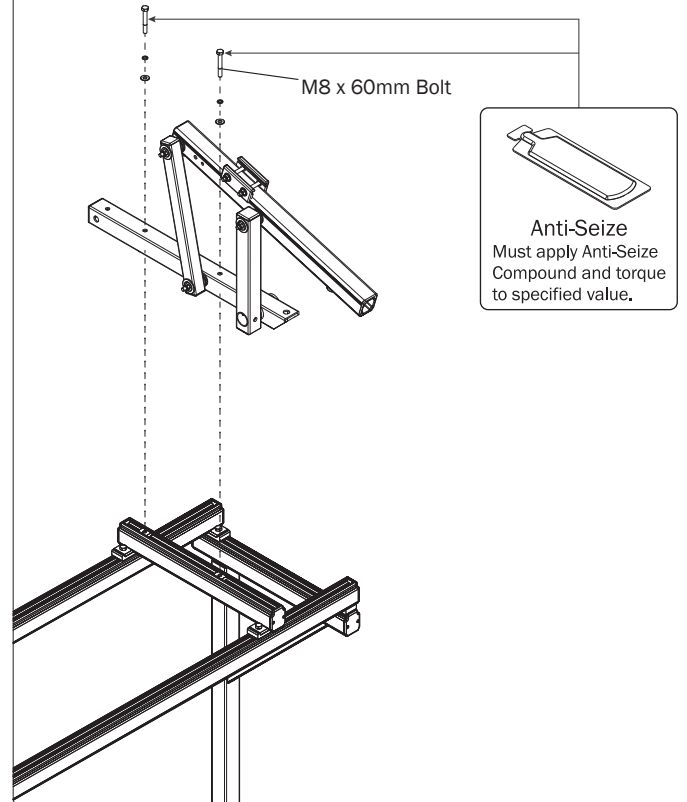



## REAR DRIVE SHAFT

NOTE: For instructional clarity, the FBM Mounting System will not be shown for the remainder of this Assembly Manual.

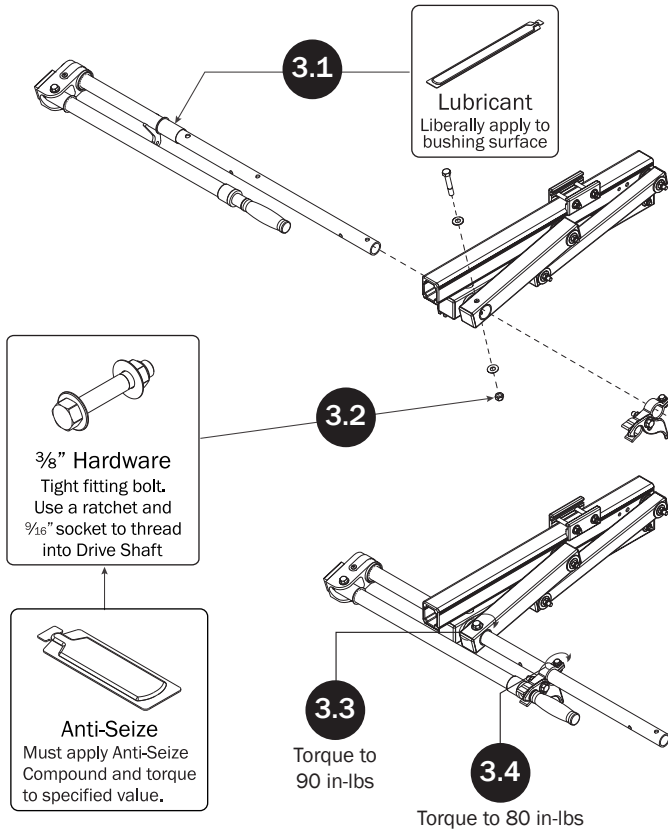

## CYLINDER HARDWARE

NOTE: Loosen the Cylinder Flow Control Screw (Fig. B) as needed to allow movement for this step sequence.

When finished with Cylinder Hardware, tighten the Flow control Screw all the way closed then turn back open  $1\frac{1}{2}$  turn.

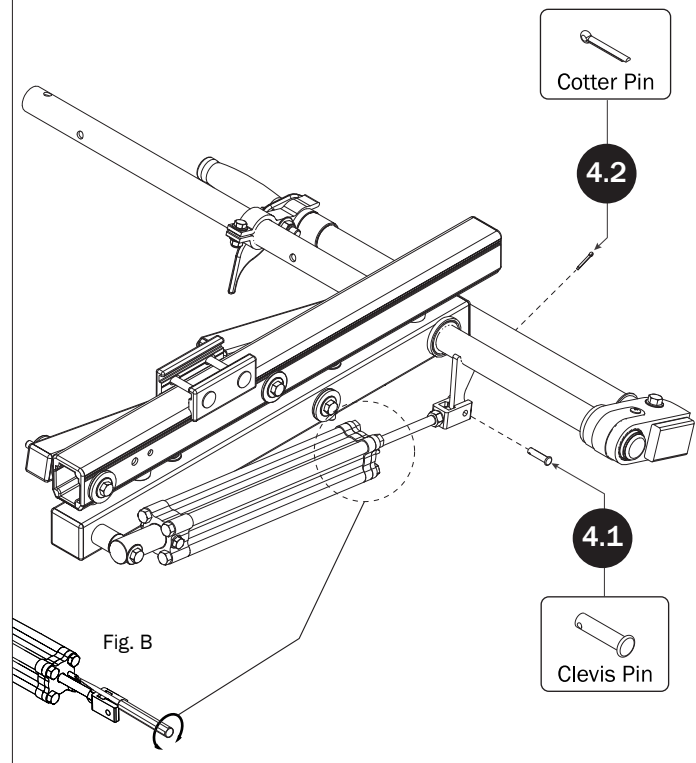

## CONNECTING BAR

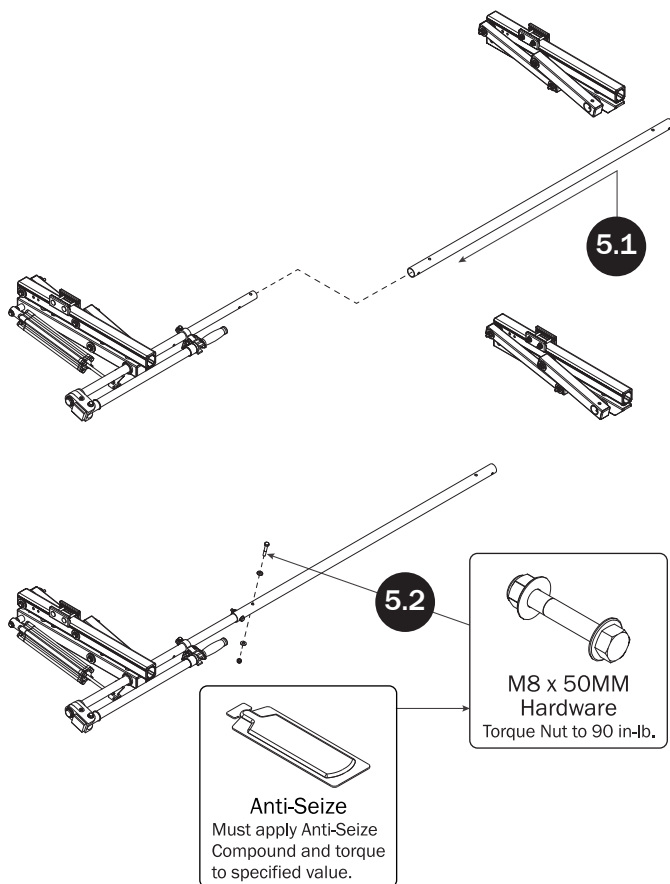

## FRONT DRIVE SHAFT

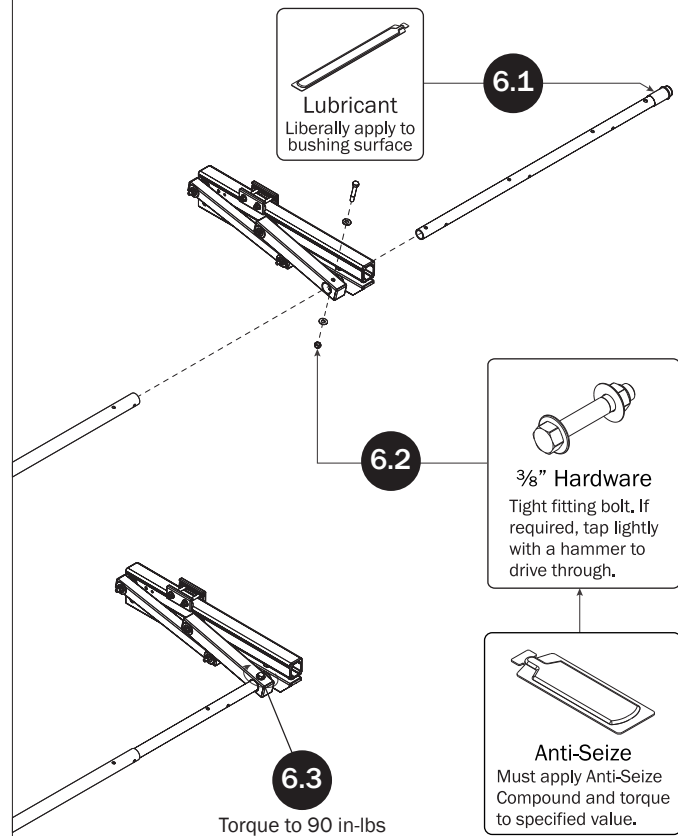

**CONNECTING BAR FASTENERS**

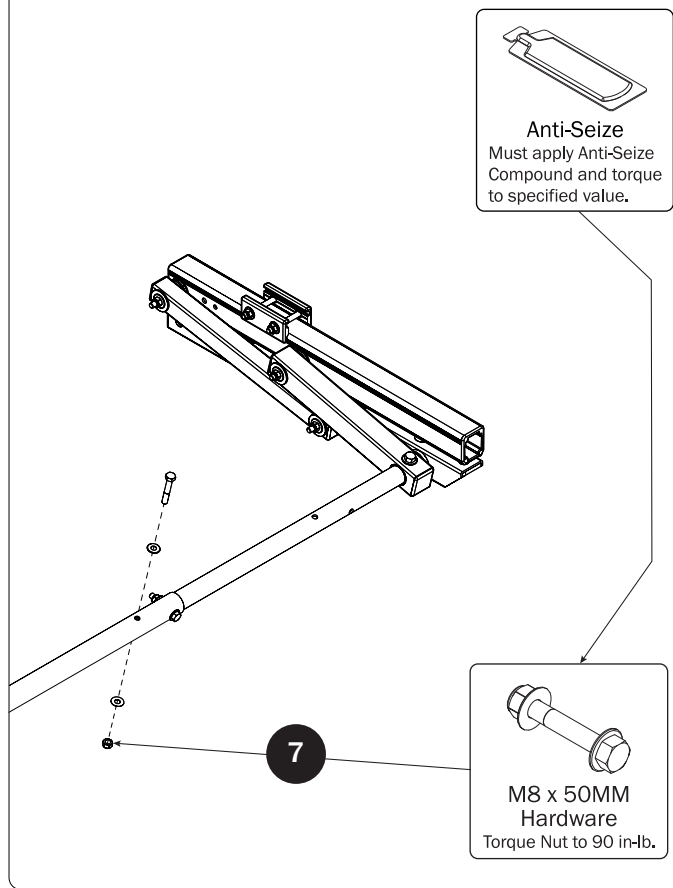

**L POSTS**

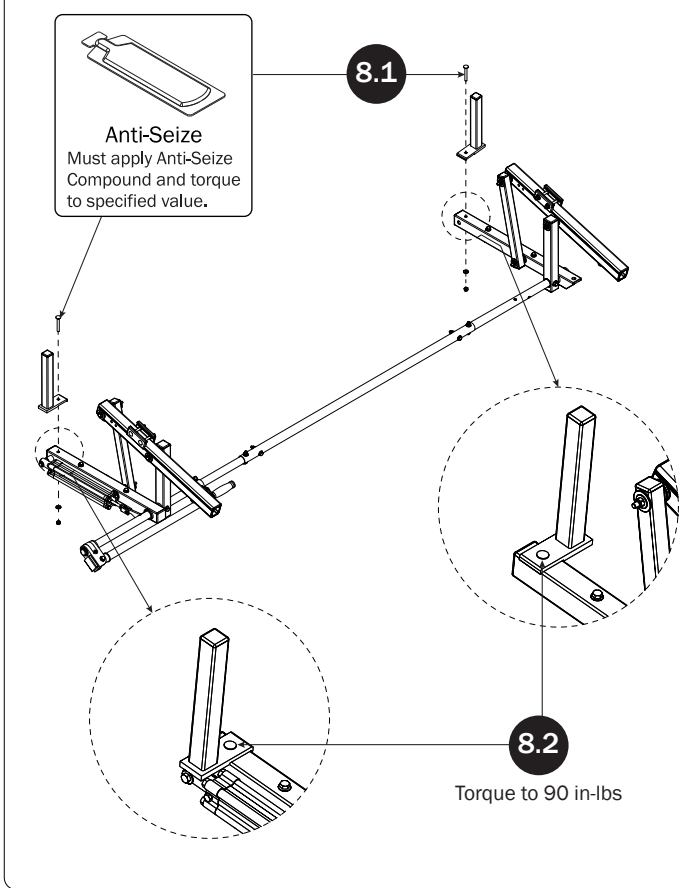

**Z POSTS**

SEE QUICK START GUIDE FOR ADJUSTMENTS

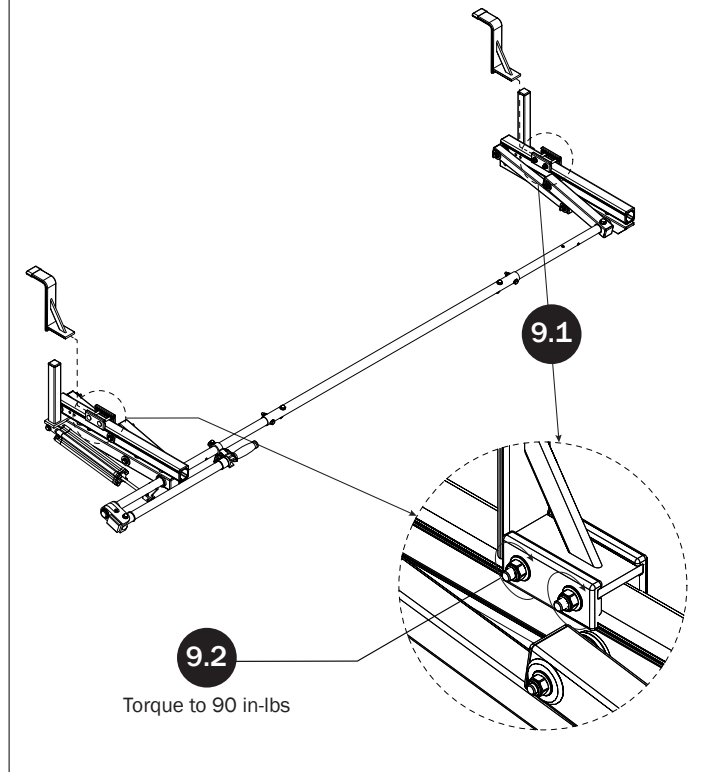

**DRIVE SHAFT SEALING**

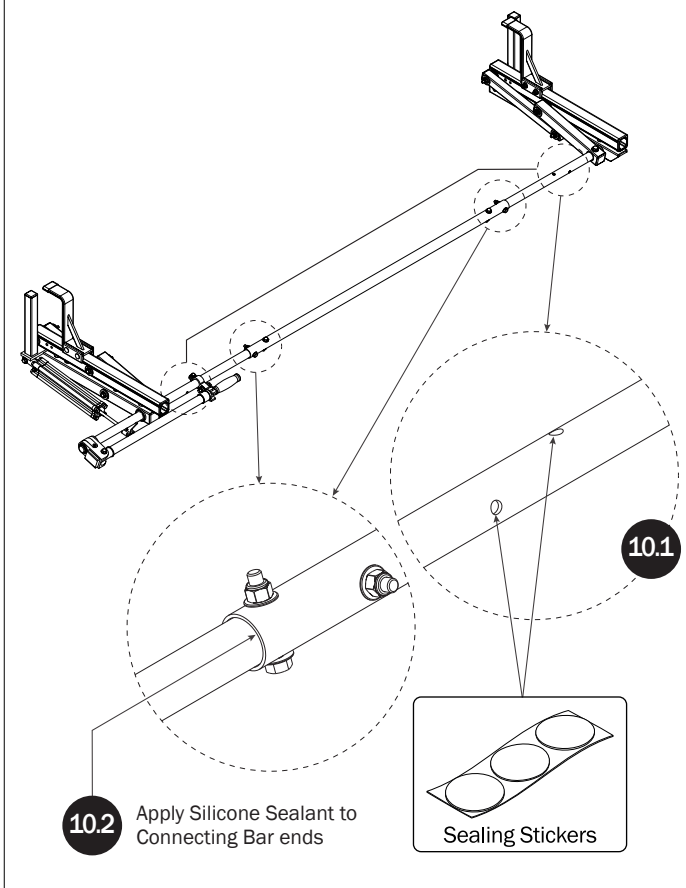

## CYLINDER ADJUSTMENT

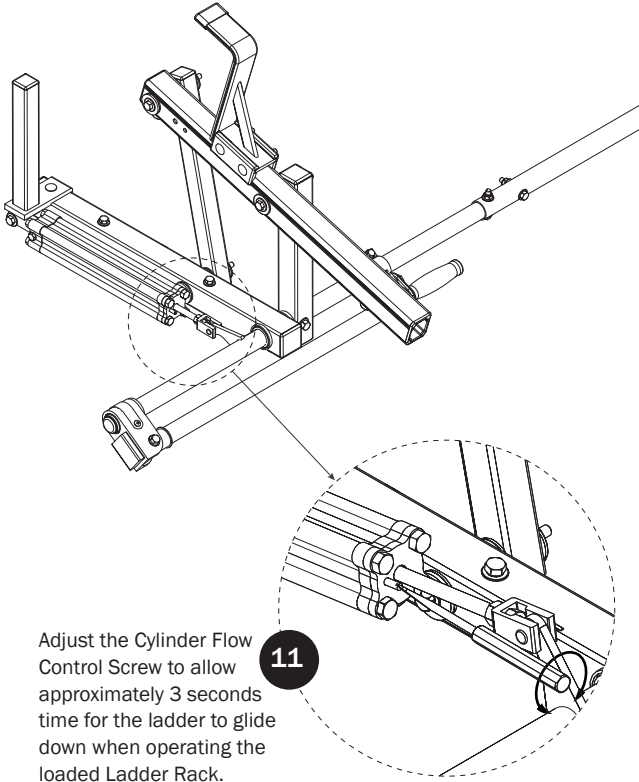

Adjust the Cylinder Flow Control Screw to allow approximately 3 seconds time for the ladder to glide down when operating the loaded Ladder Rack.

11

