

PRIME DESIGN™

A Safe Fleet Brand

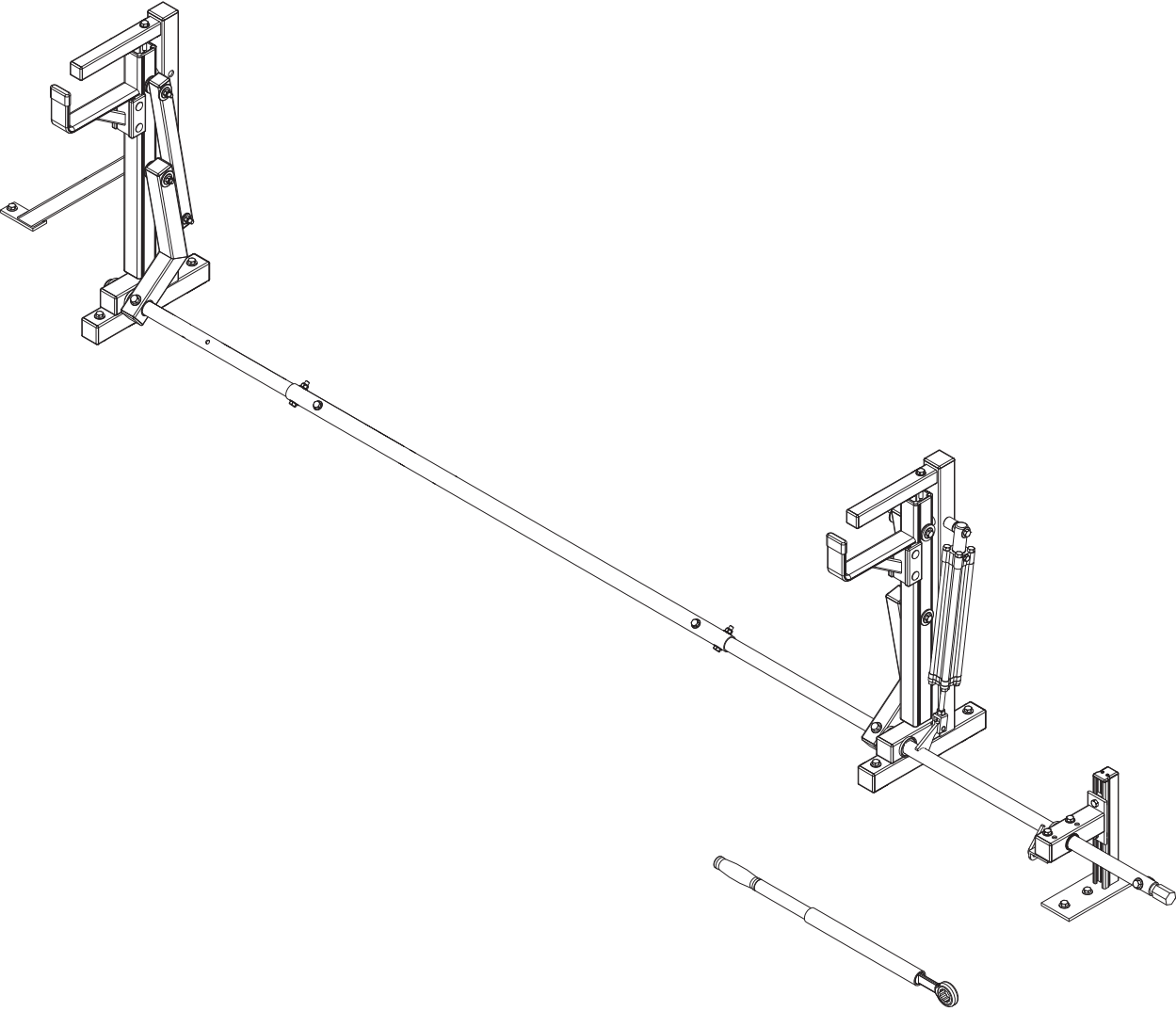

UVX 203

CONTENTS OVERVIEW

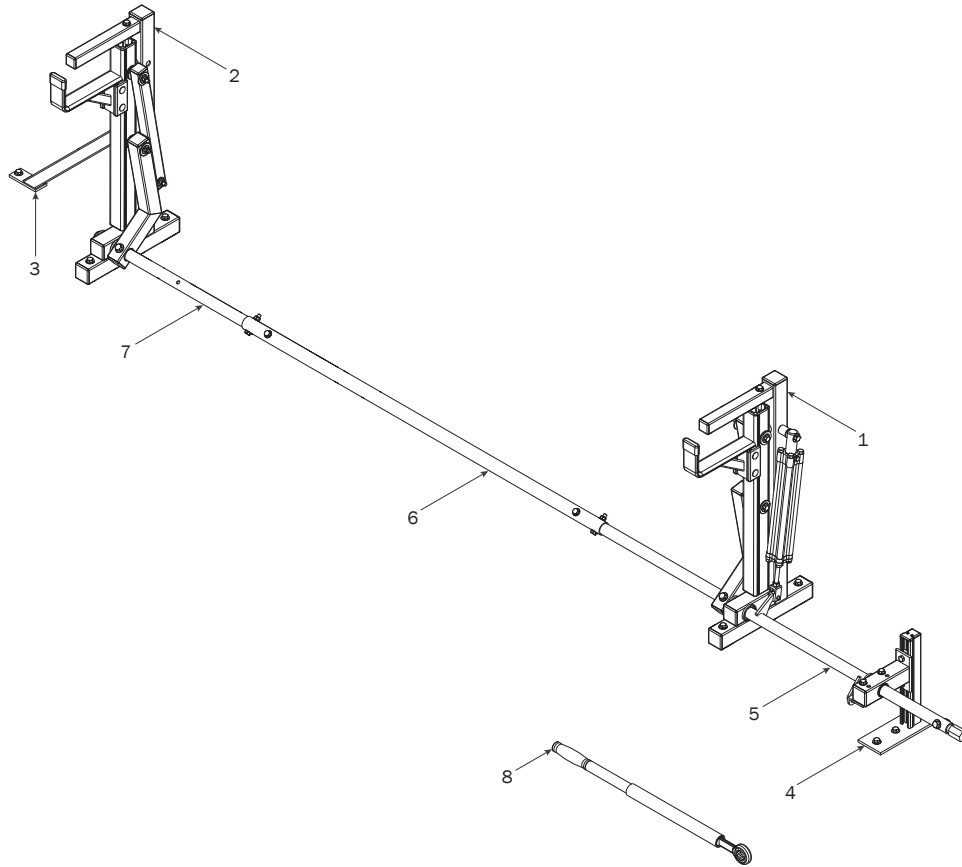

1—Rear Rotation Assembly..... (Qty 1)

2—Front Rotation Assembly..... (Qty 1)

3—Mount Brace..... (Qty 1)
20.00"

4—Vertical Drive Shaft Support..... (Qty 1)
Utility, Left Hand

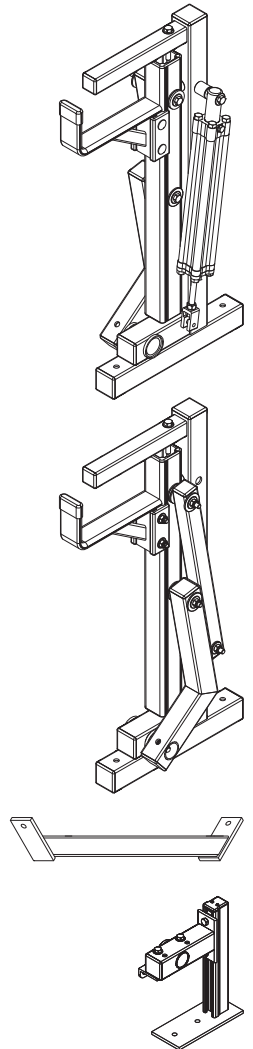

5—Rear Drive Shaft..... (Qty 1)
Hex Head, Left Hand, 50.00”

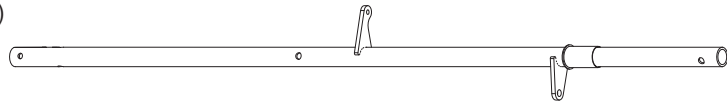

6—Connecting Bar..... (Qty 1)
48.00”

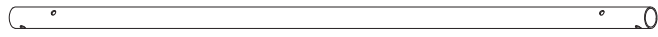

7—Front Drive Shaft (Qty 1)
B Version, 35.75”

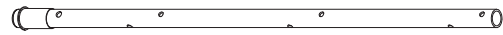

8—Ratcheting Handle Assembly (Qty 1)



HKT-8163-Rotation Hardware Kit

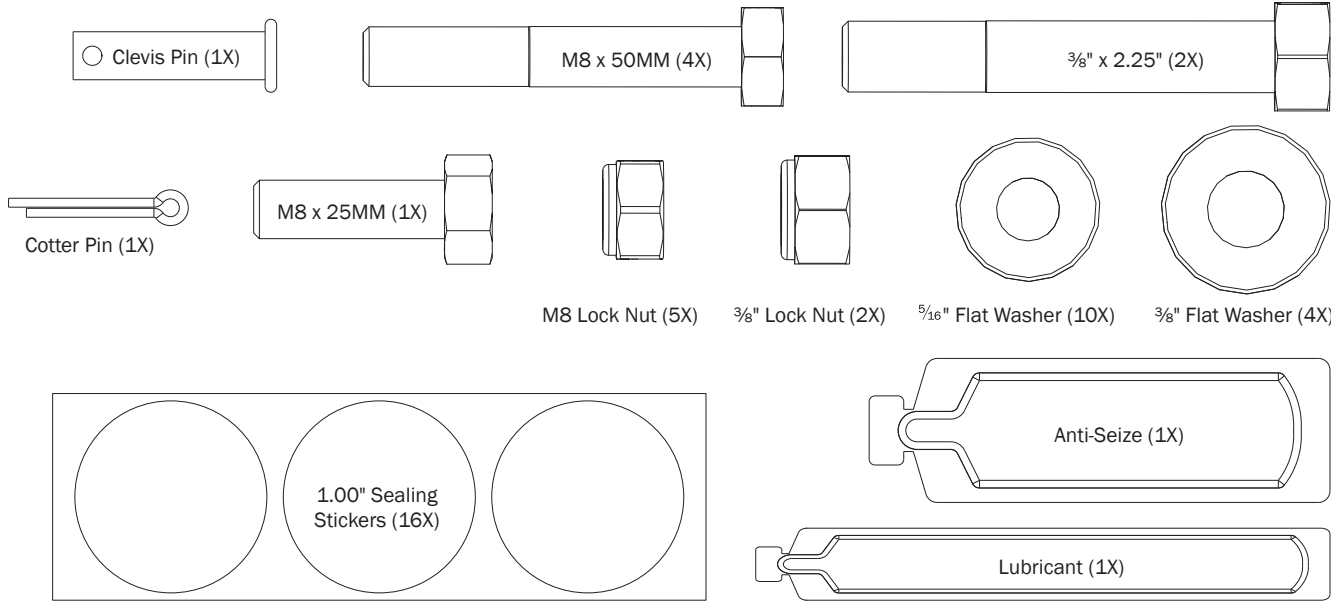

HKT-0255-Hardware Kit

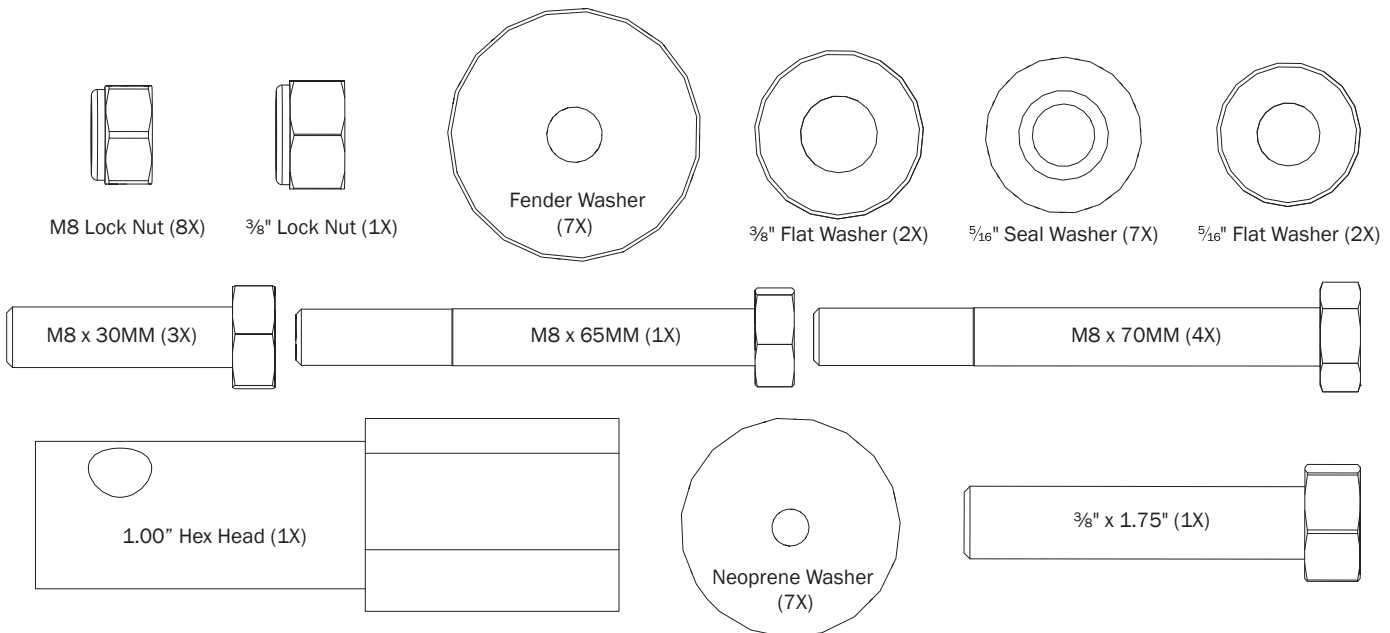

MOUNTING DIMENSIONS



Mounting to Service Body: dimensions are dependent upon Crossbar distances of 6'-8' plus allowance for the Mount Brace from the front of the Utility Rack.

Allow spacing for the Mount Brace, but do not drill or install until Step 10.

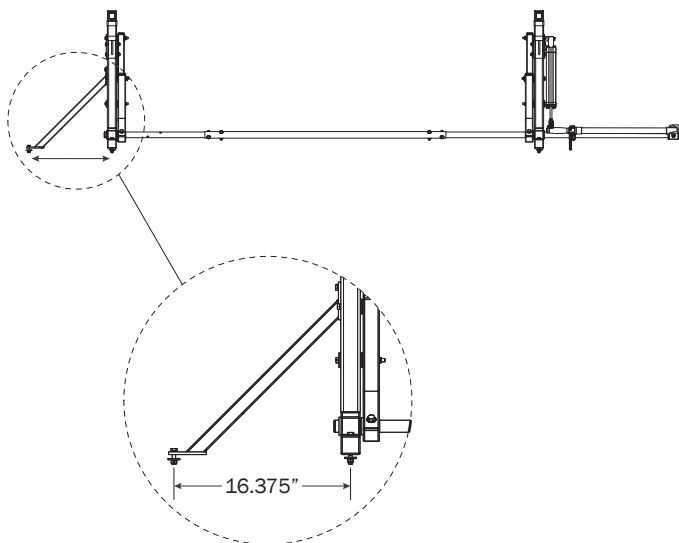

0.1 6.00 Ft: Drill holes into the Service Body mounting location according to dimensions shown.

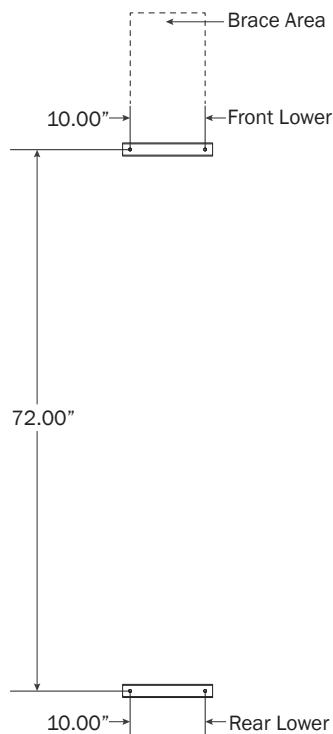

0.2 7.00 Ft: Drill holes into the Service Body mounting location according to dimensions shown.

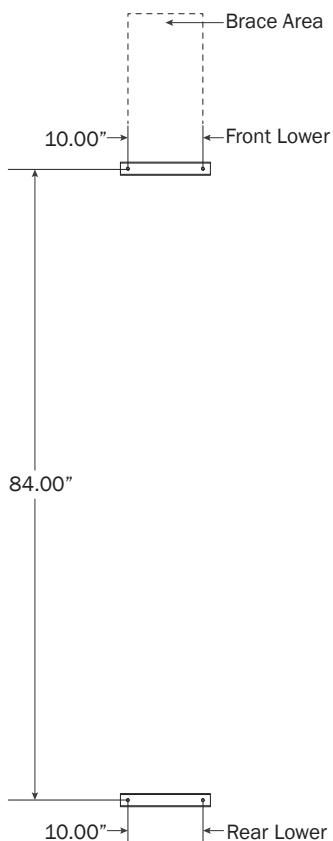

0.3 8.00 Ft: Drill holes into the Service Body mounting location according to dimensions shown.

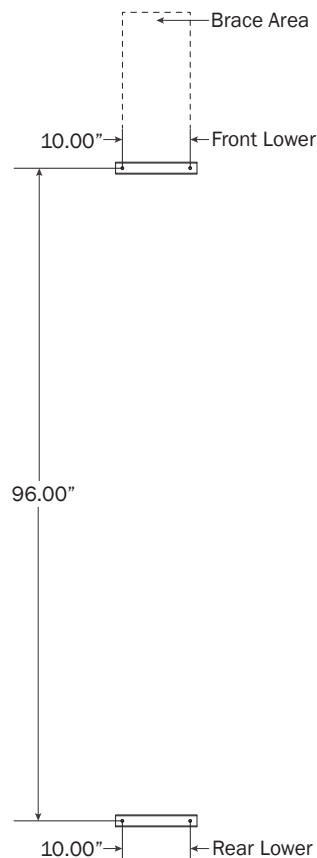

LEFT ROTATION ASSEMBLY SEQUENCE

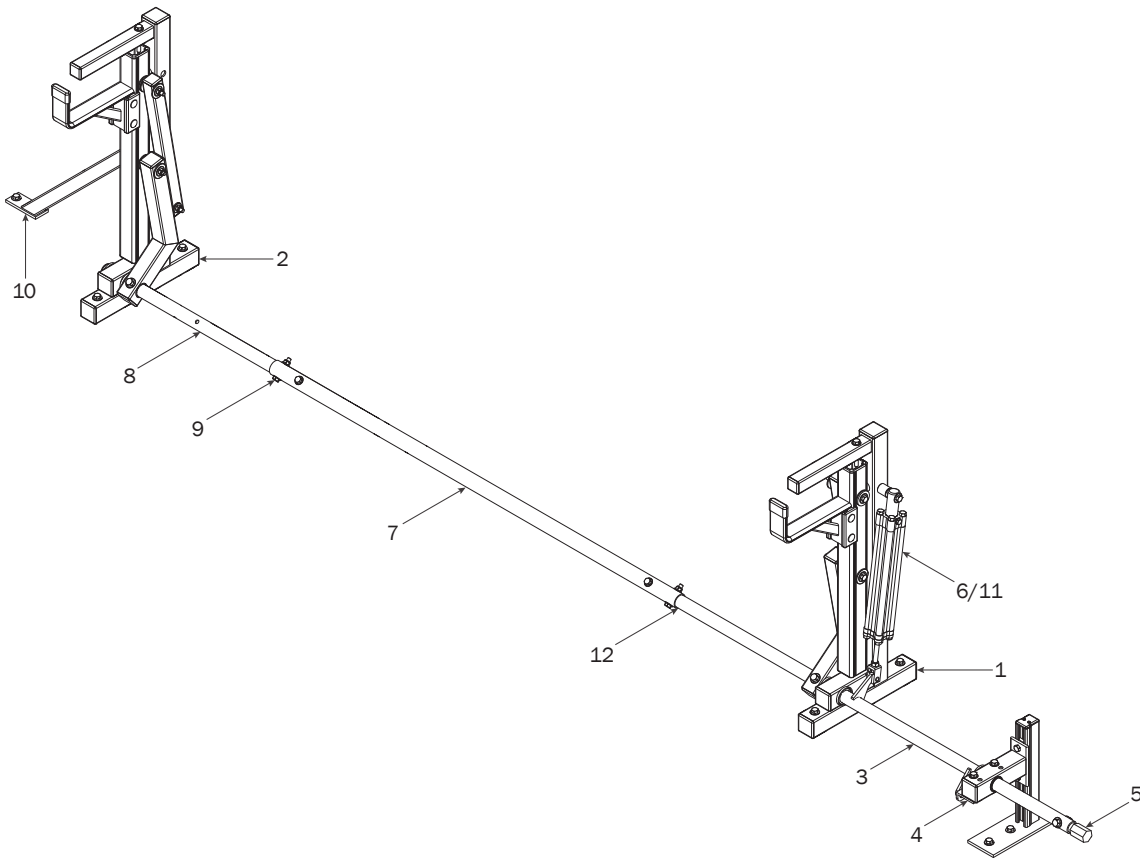

REAR ROTATION ASSEMBLY

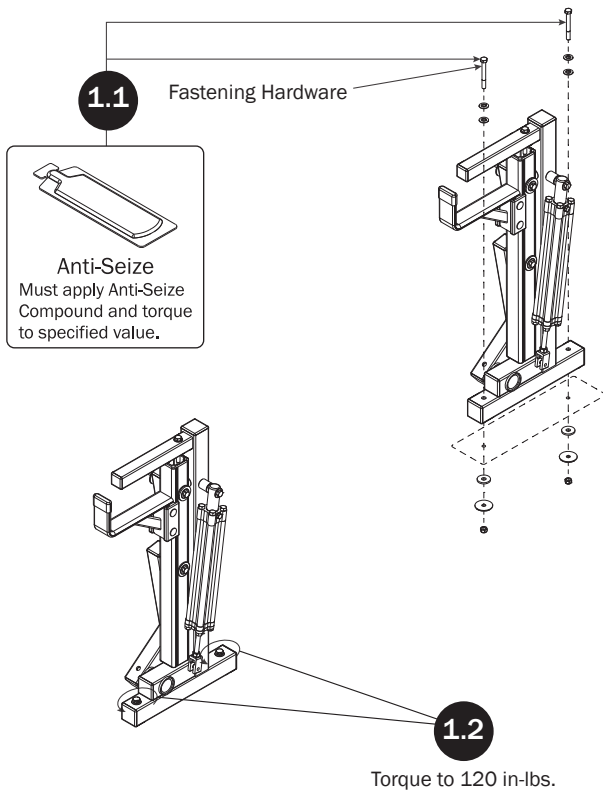

FRONT ROTATION ASSEMBLY

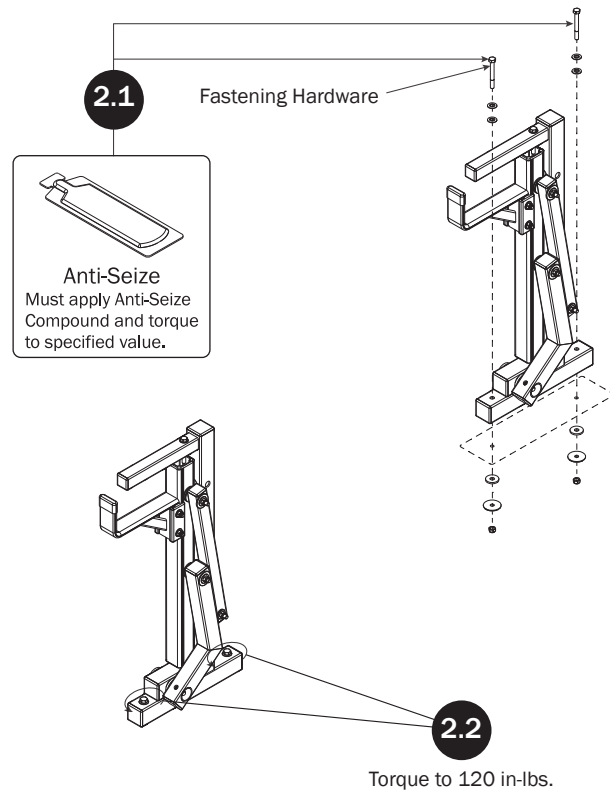

REAR DRIVE SHAFT

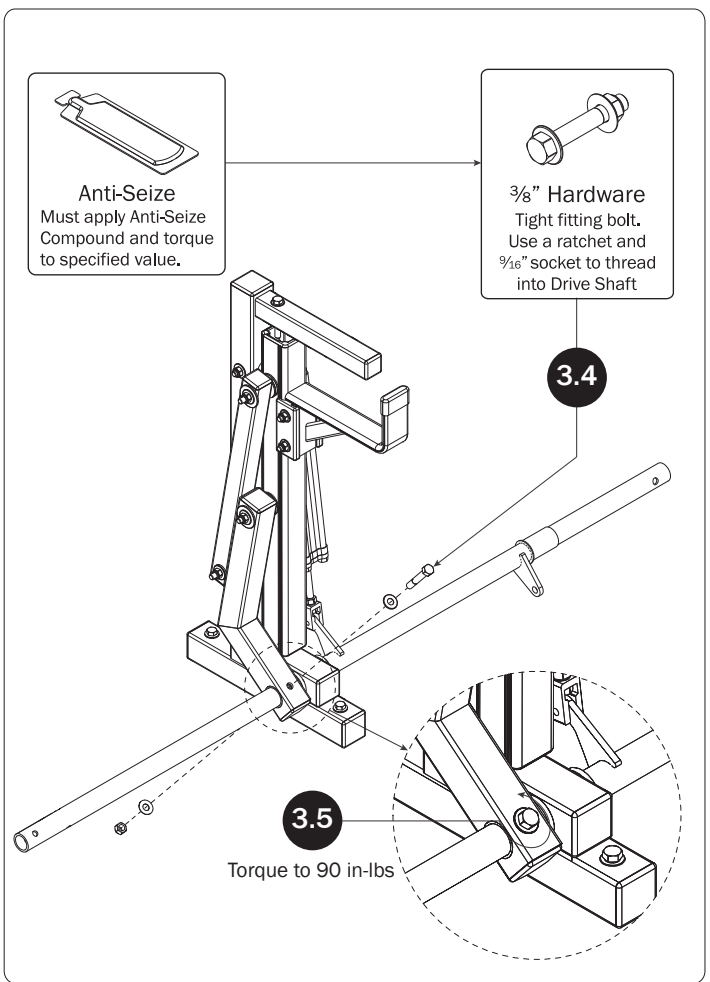
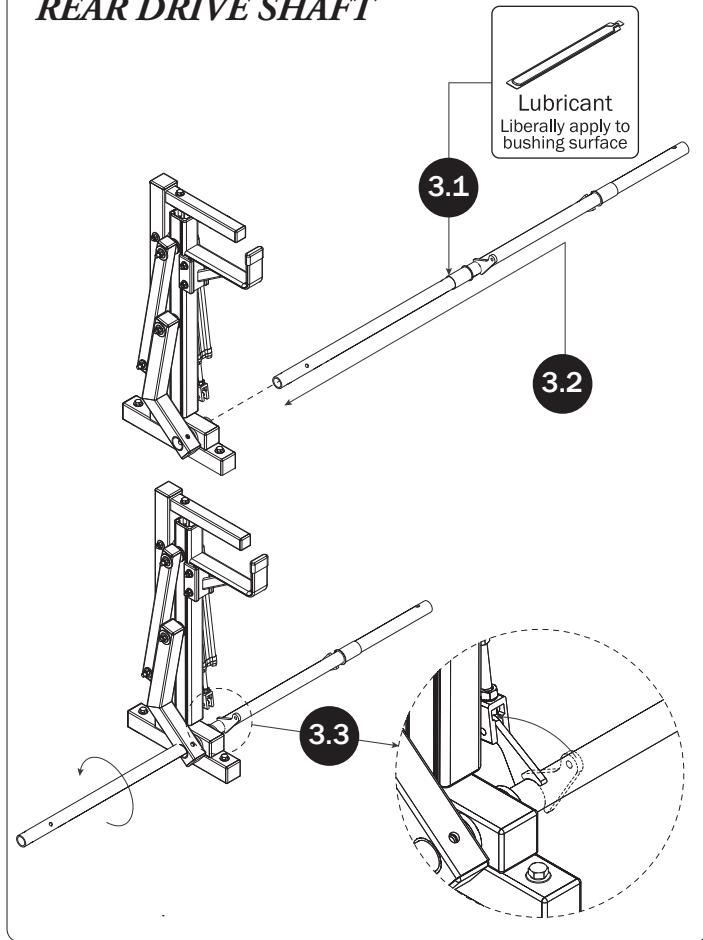

DRIVE SHAFT SUPPORT

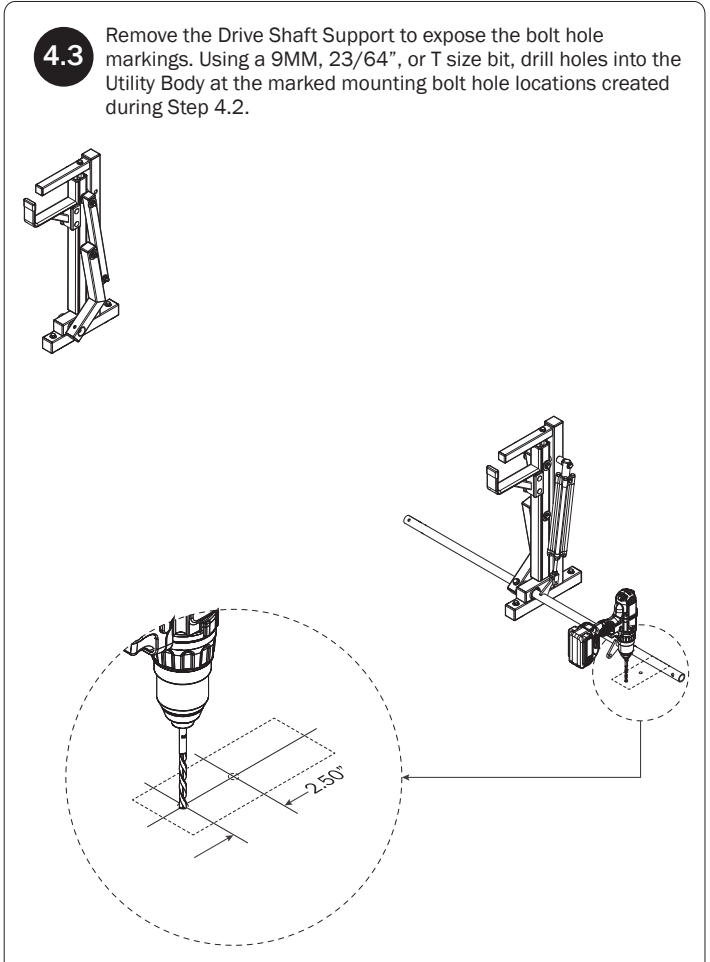
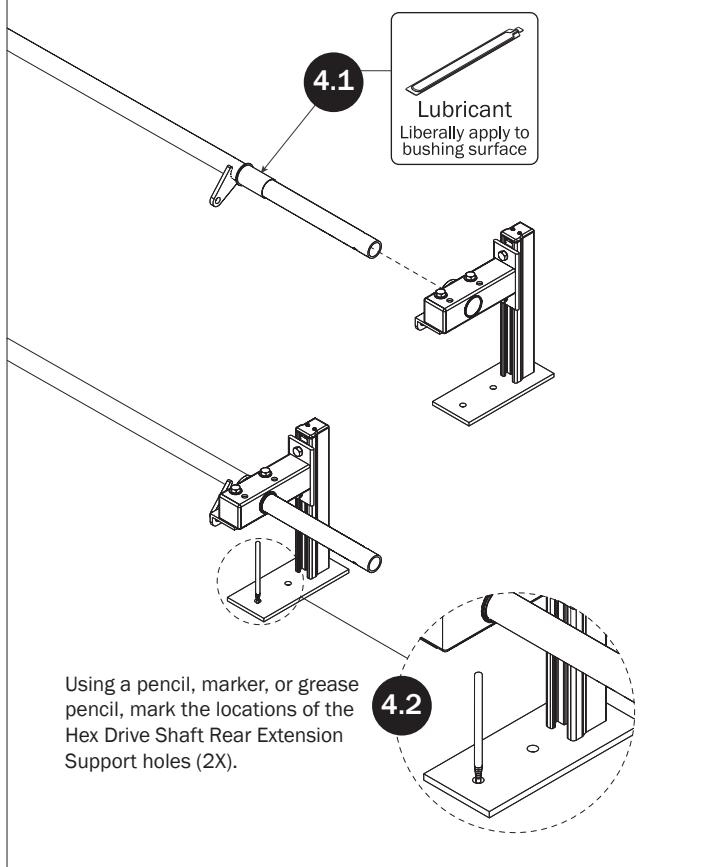

DRIVE SHAFT HEX STUD

5.1 Insert the Drive Shaft Hex Stud into the open end of the Drive Shaft Extension. Align the bolt holes, then install the 3/8" x 1.75" Hex Stud Bolt (1X), 3/8" Washer (2X), and 3/8" Lock Nut (1X) in the order shown.

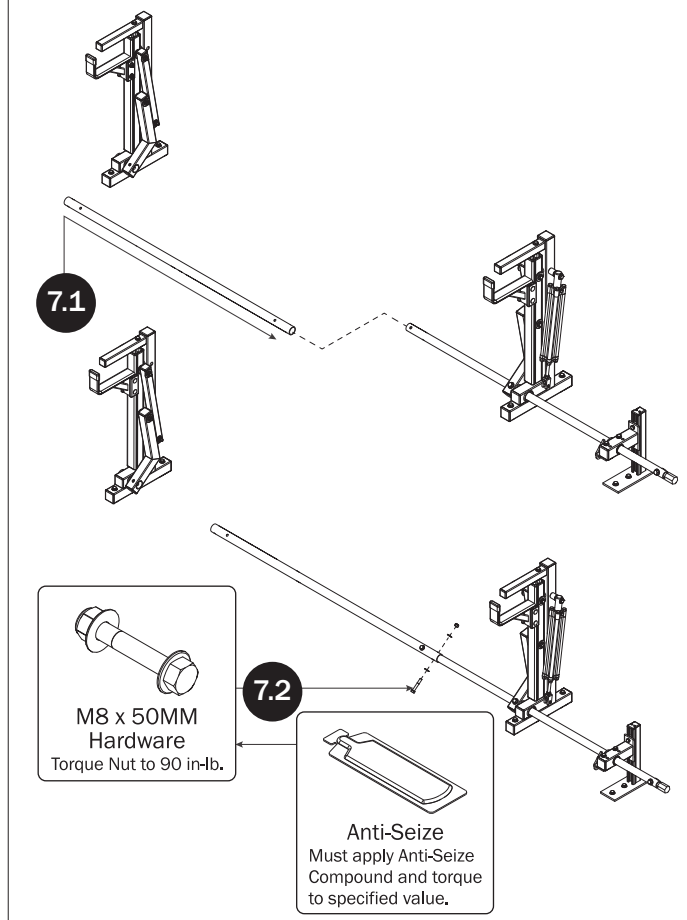
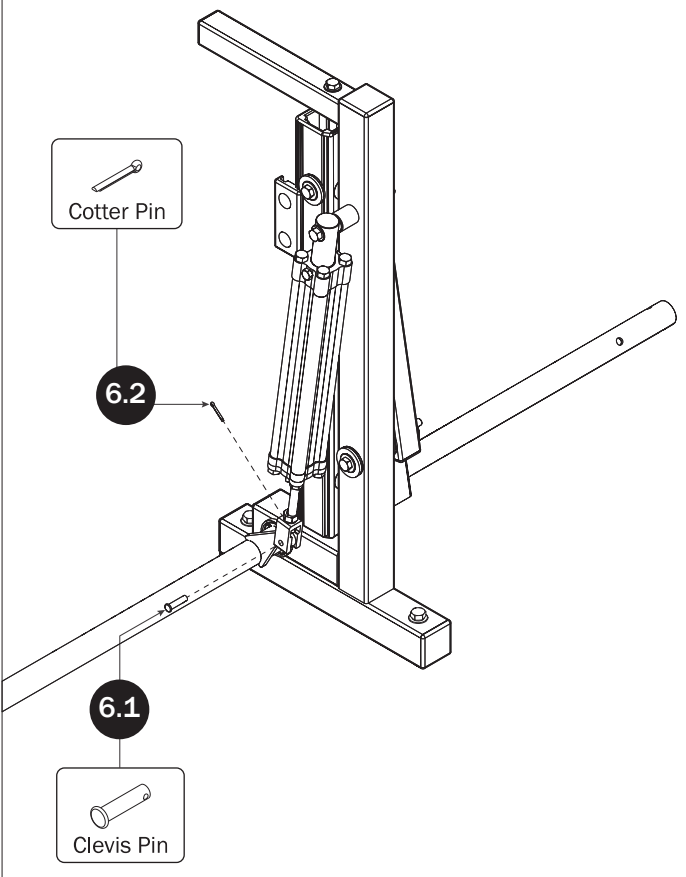
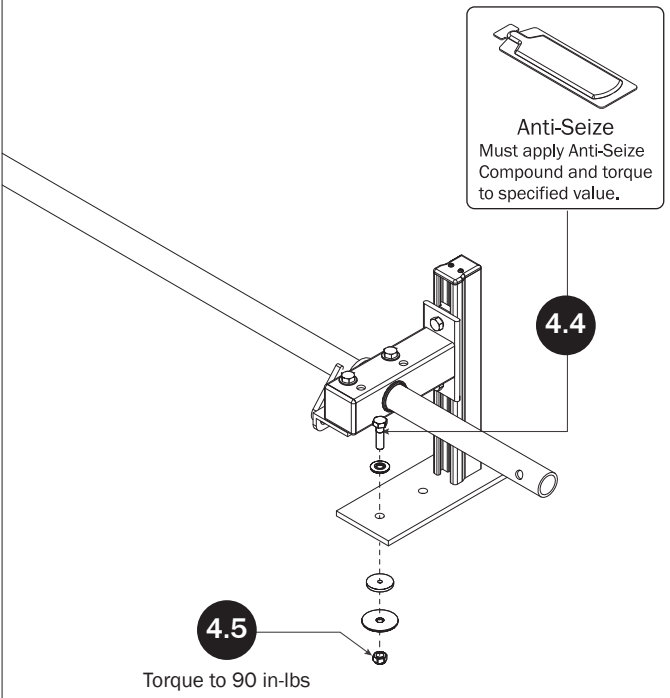
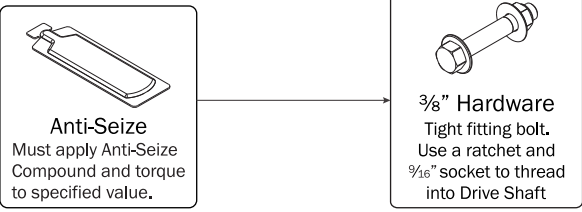
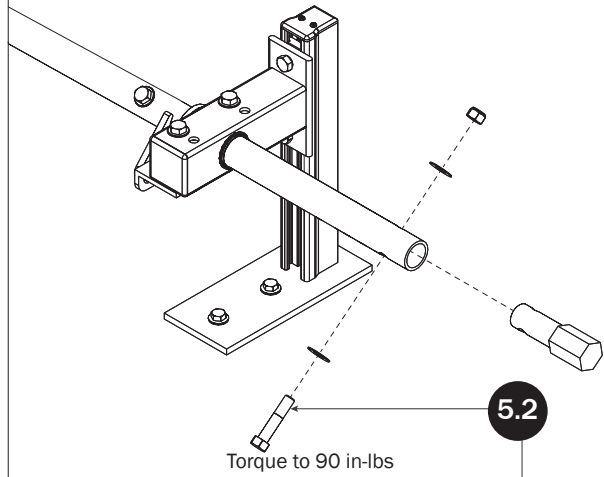

FRONT DRIVE SHAFT

8.1 Lubricant
Liberally apply to bushing surface

8.2

8.3 $\frac{3}{8}$ " Hardware
Tight fitting bolt. Use a ratchet and $\frac{9}{16}$ " socket to thread into Drive Shaft

8.4 Anti-Seize
Must apply Anti-Seize Compound and torque to specified value.

Torque to 90 in-lbs

CONNECTING BAR FASTENERS

9 M8 x 50MM Hardware
Torque Nut to 90 in-lb.

Anti-Seize
Must apply Anti-Seize Compound and torque to specified value.

MOUNT BRACE INSTALLATION

10.1 Using a pencil, marker, or grease pencil, mark the location of the hole for installing the Mount Brace onto the Utility Rack. Repeat the procedure for installing the Mount Brace to the truck body.

10.2 Remove the Mount Brace to expose the bolt hole markings. Using a 9MM, 23/64", or T size bit, drill a hole into the Utility Rack at the marked bolt hole location created during Step 10.1.

10.3 Repeat Step 8.2 procedure using the indicated bit to drill a hole into the truck body.

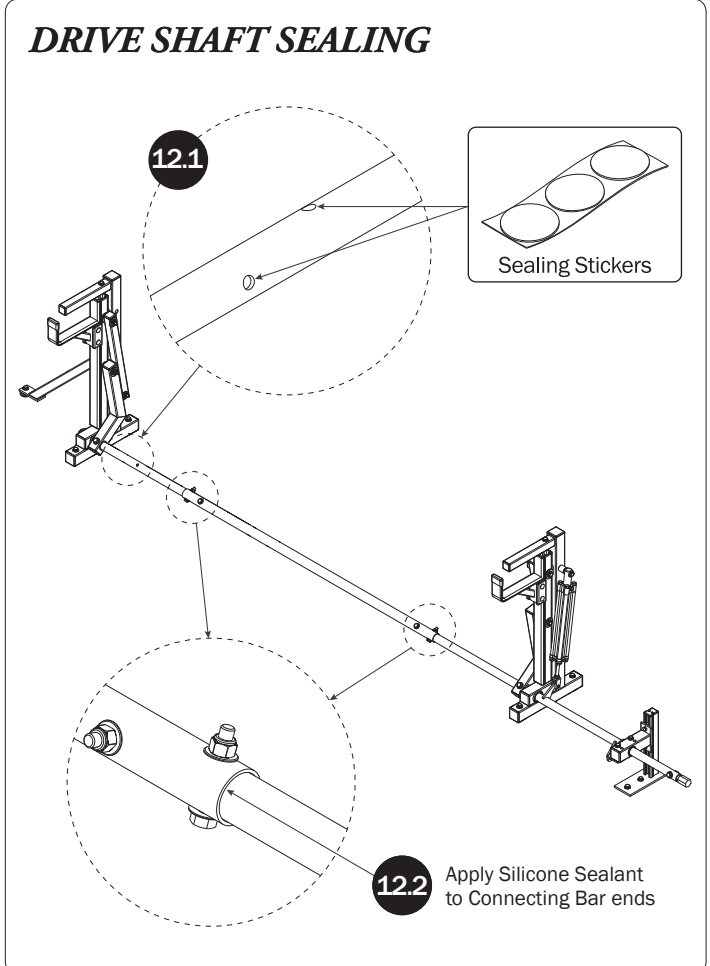
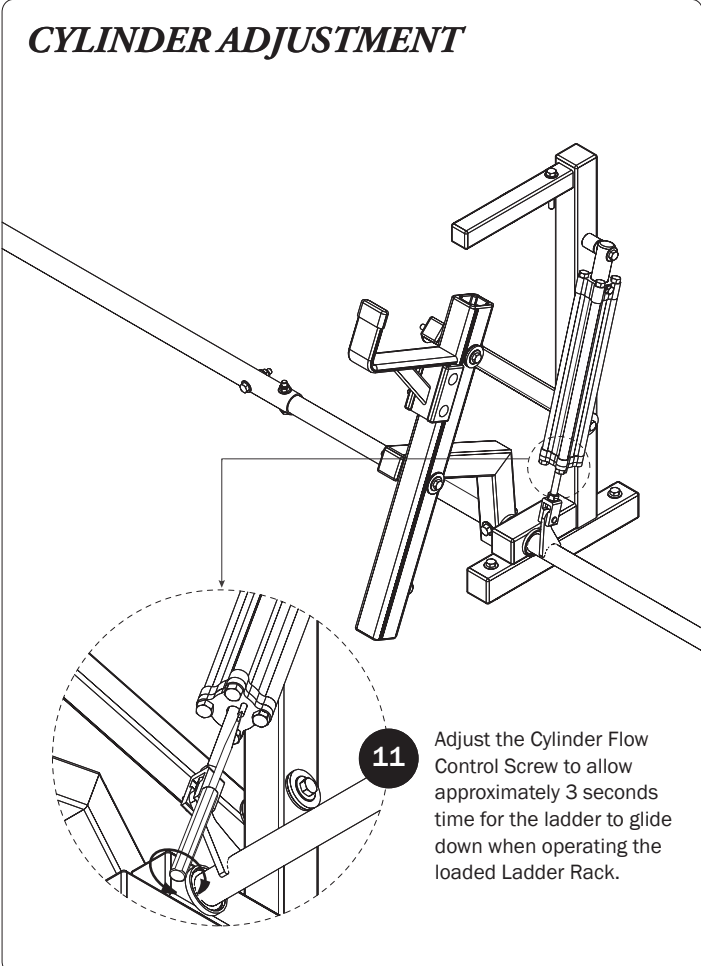
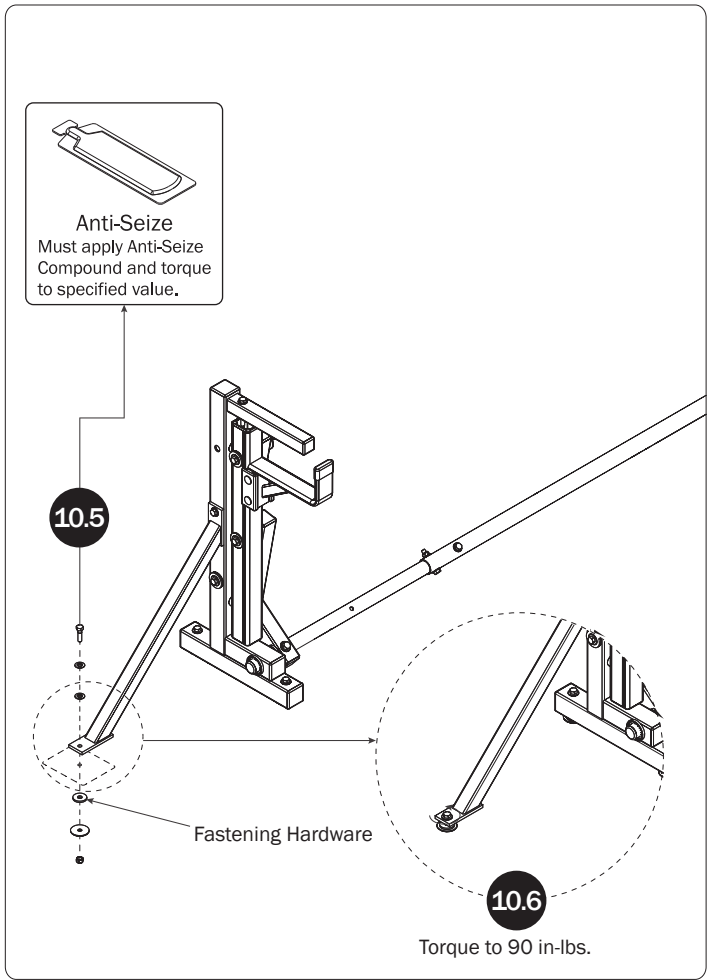
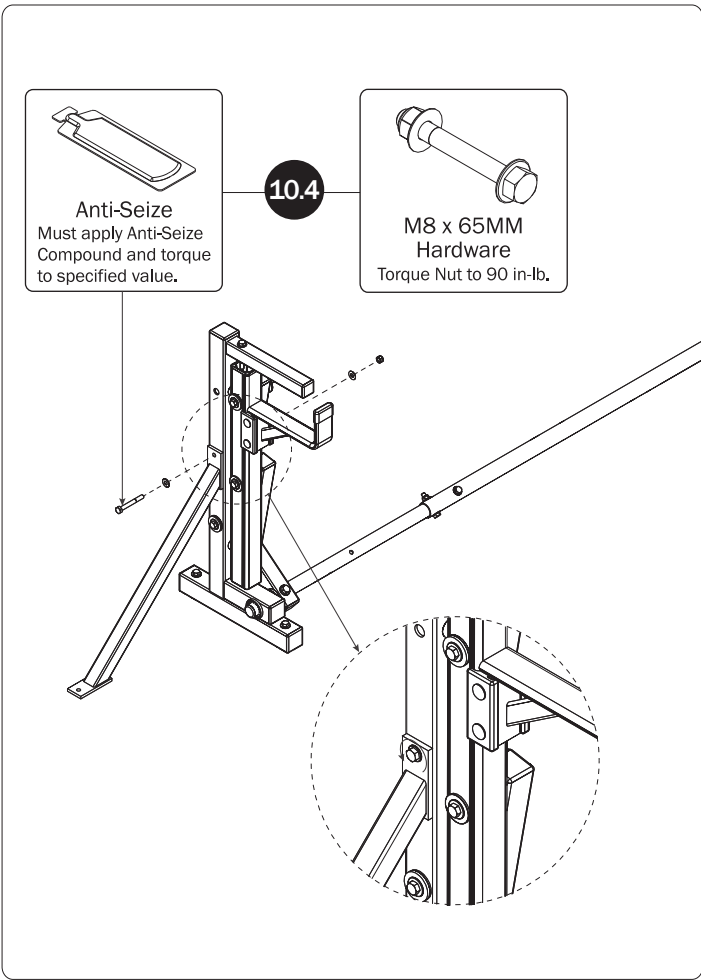

Page Intentionally Left Blank

Page Intentionally Left Blank

