

PRIME DESIGN™

A Safe Fleet Brand

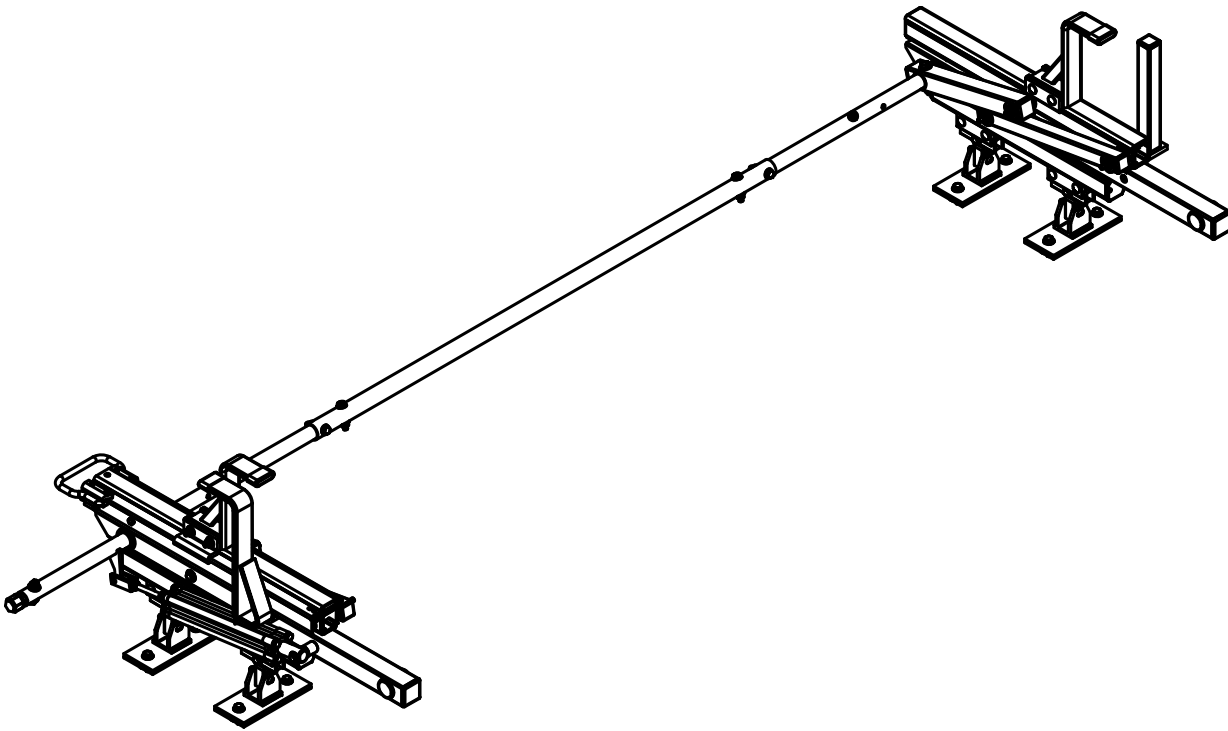

URX 0026

PRIME DESIGN, A SAFE FLEET BRAND

Address: 580 Opperman Drive, Eagan, MN 55123 • Toll Free: 1.8.PRIME.RACK
Fax: 651-552-1799 • Email: info@primedesign.net • Website: www.primedesign.net

CONTENTS OVERVIEW

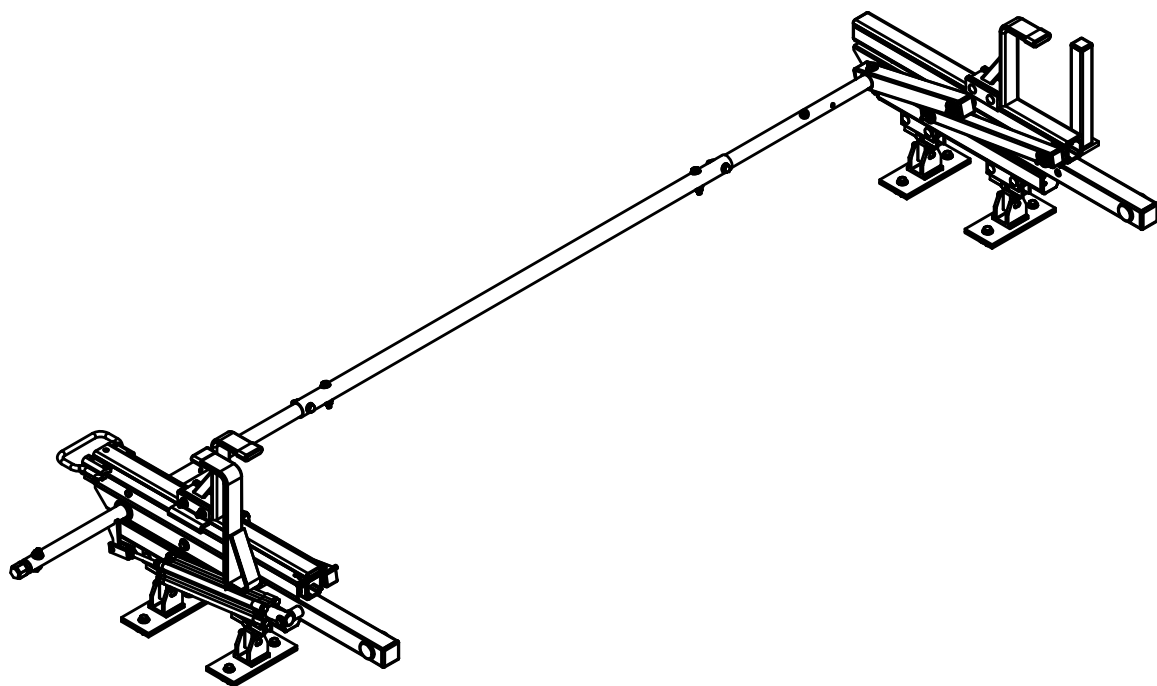

1—FBM-1029..... (Qty 1)
Utility Roof Mounts, with HKT-8266

NOTE: The M8 x 35MM and M8 x 45MM Mounting Bolts are available in the HKT-8266 Hardware Kit for varying mounting surfaces and thickness.

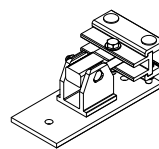

Mounting Bracket (4X)

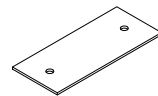

Foam Pad (4X)

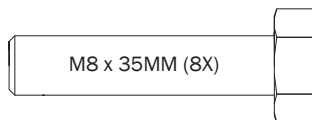

M8 x 35MM (8X)



M8 x 45MM (8X)

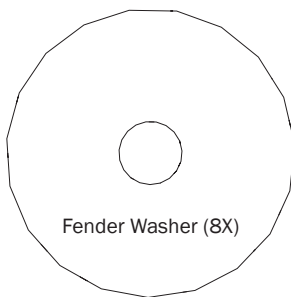

Fender Washer (8X)

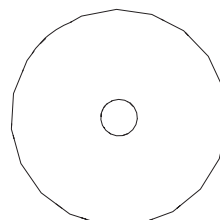

Neoprene Washer (8X)

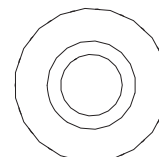

Sealing Washer (8X)

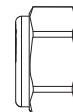

Lock Nut (8X)

3—Rear Rotation Assembly..... (Qty 1)

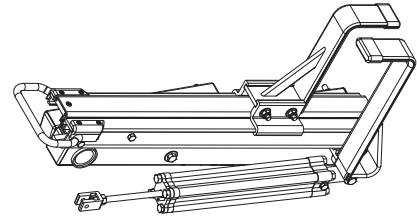

4—Front Rotation Assembly..... (Qty 1)

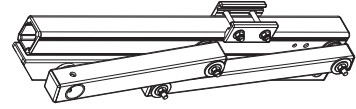

5—Rear Drive Shaft..... (Qty 1)
Left Hand, B4 Version, 50.00"

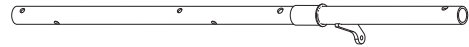

6—Connecting Bar..... (Qty 1)
48.00"



7—Front Drive Shaft (Qty 1)
B Version, 35.75"

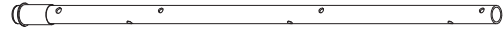

8—Ratcheting Handle Assembly (Qty 1)
With Hardware

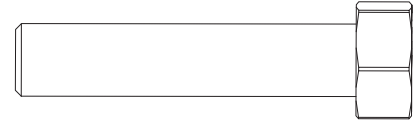
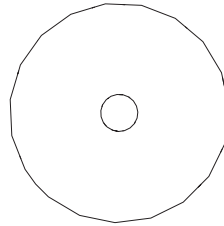
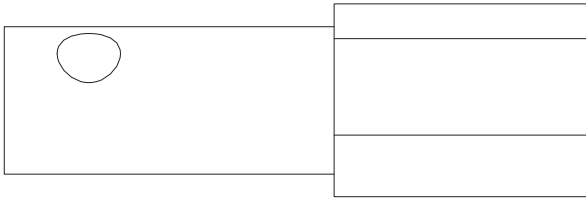

9—Z Post (Qty 1)
Adjustable, 7.25"

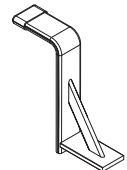

10—L Post..... (Qty 1)
9.25"

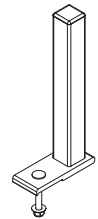

11—USQSG-Ergorack (Qty 1)
Quick Start Guide, Rotation

* Once rack installation is complete, place the Quick Start Guide into the vehicle's glove box for future ladder setup and adjustment.



11—HKT-8163 (Not called out in Overview)..... (Qty 1)

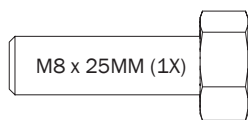

M8 x 25MM (1X)



M8 x 50MM (4X)

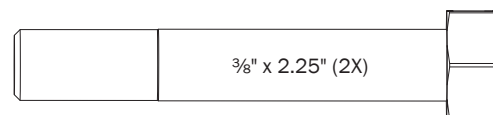

3/8" x 2.25" (2X)



Cotter Pin (1X)



Clevis Pin (1X)

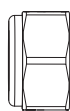

M8 Lock Nut (5X)



3/8" Lock Nut (2X)

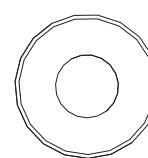

5/16" Flat Washer (10X)

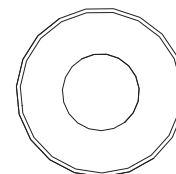

3/8" Flat Washer (4X)

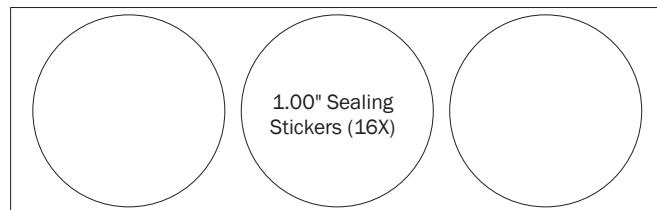

1.00" Sealing Stickers (16X)

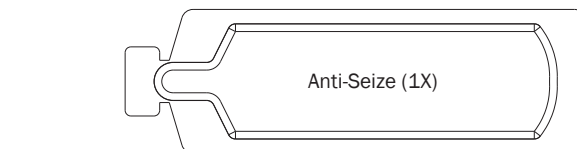

Anti-Seize (1X)

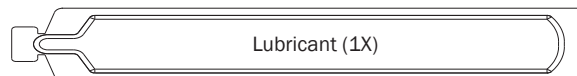

Lubricant (1X)

UTILITY ROOF MOUNTINGS MOUNTING BRACKETS TO ROOF

1.1 Drill bolt holes according to the dimensions shown.

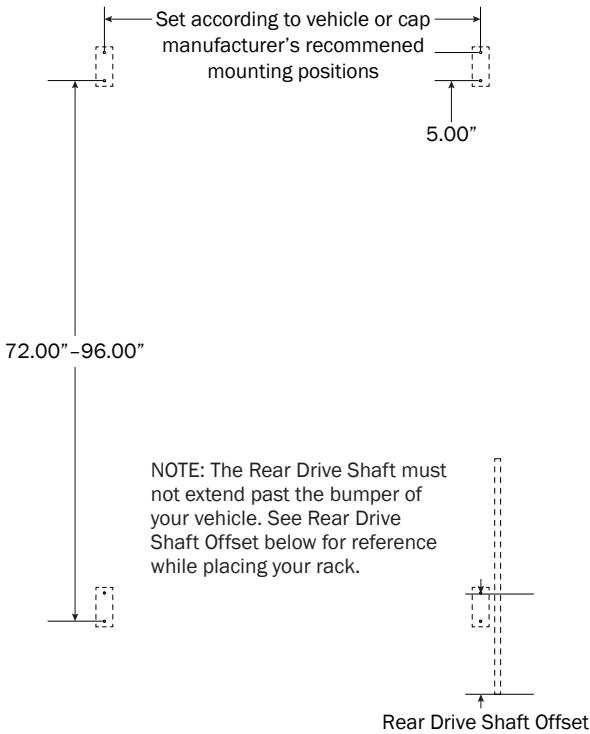

1.2 Assemble unto vehicle roof as shown, then torque the Mounting Feet nuts to 130 in-lbs.

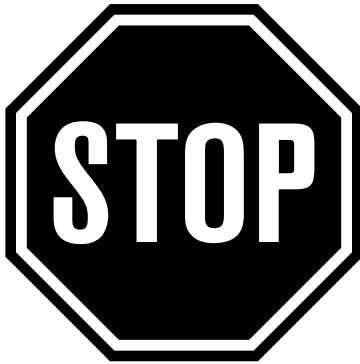
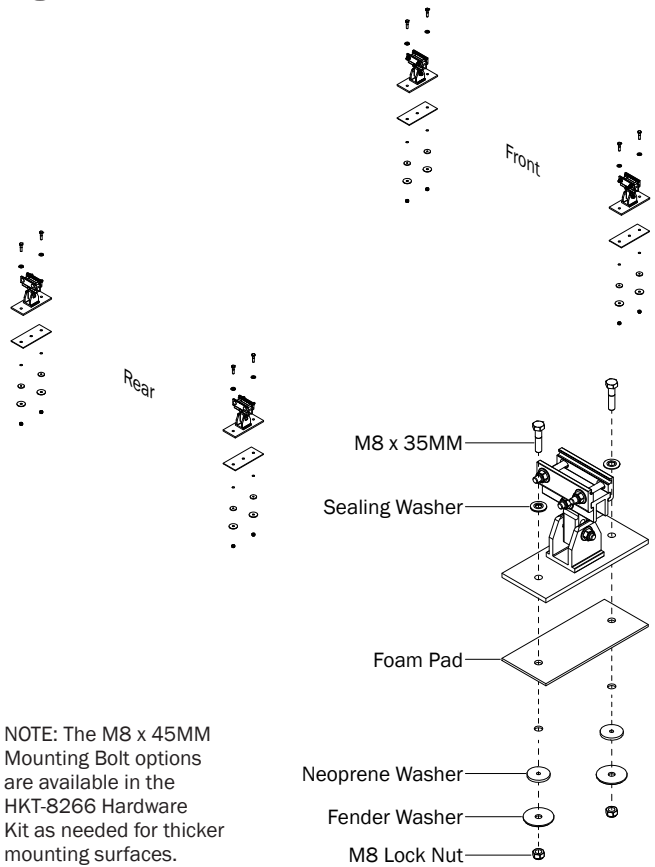

Do not mount the Crossbars to this FBM system at this time.

Refer to the respective FEA or AR Assembly Manual(s) included with your chosen rack configuration features. Depending upon the features chosen, you may need to perform a complete feature assembly onto the Crossbars or Side Rails as noted in that feature's Assembly Manual.

WARNING: Failure to position the Crossbars as shown in this FBM Assembly Manual may result in damage to the sliding door and/or ladder rack.

NOTE: Crossbars, Side Rails, Base, Clamp Down, or Rotation features are not included in this FBM kit, and must be purchased separately. To purchase applicable features and accessories, please contact your authorized distributor, or a Prime Design Sales & Service Representative.

LEFT ROTATION ASSEMBLY SEQUENCE

NOTE: For instructional clarity, the FBM Mounting System will not be shown for the remainder of this Assembly Manual.

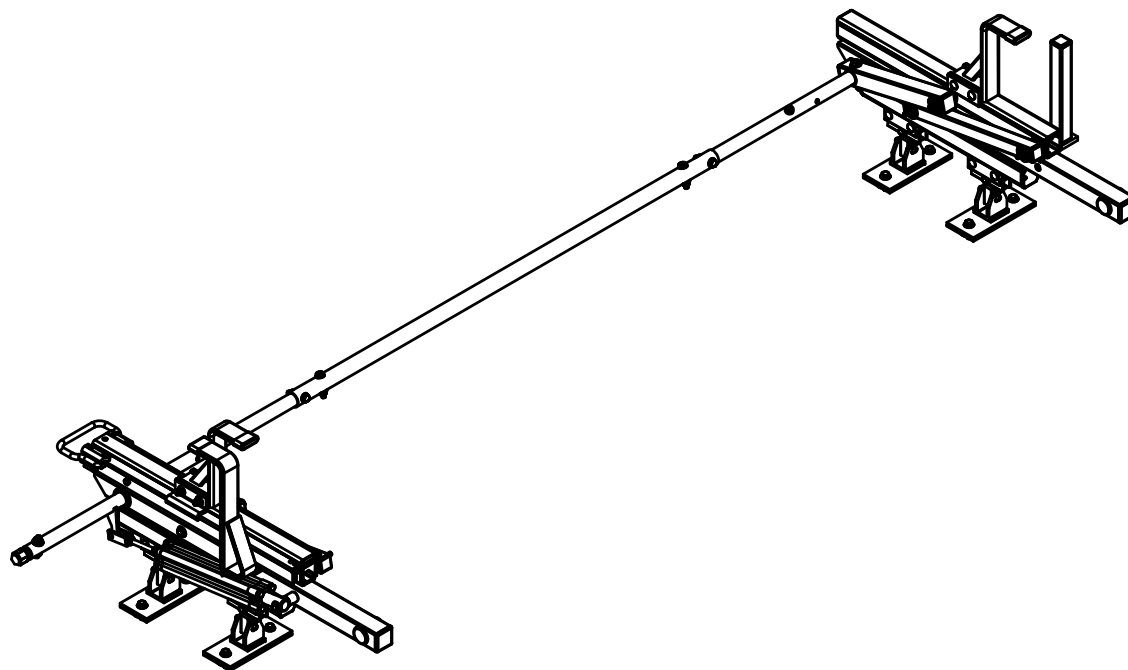
**REAR ROTATION ASSEMBLY**

- 1** Place Rear Crossbar onto FBM as shown and torque to 90 in-lbs.

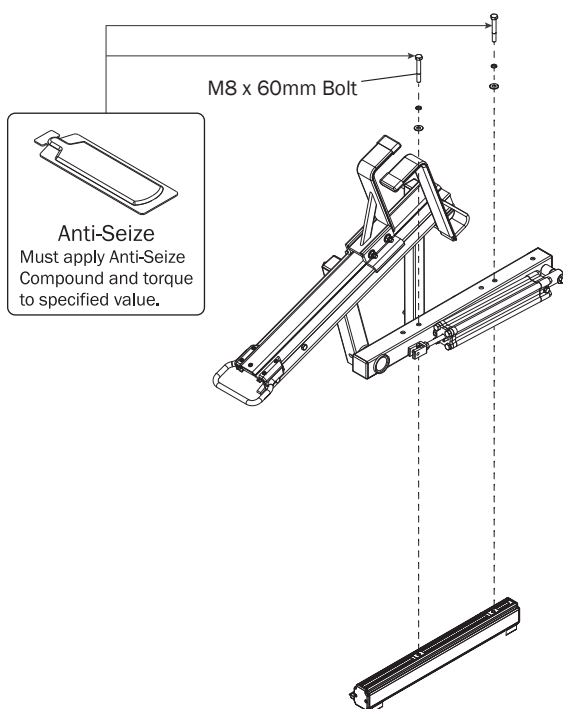
**FRONT ROTATION ASSEMBLY**

- 2** Place Front Crossbar onto FBM as shown and torque to 90 in-lbs.

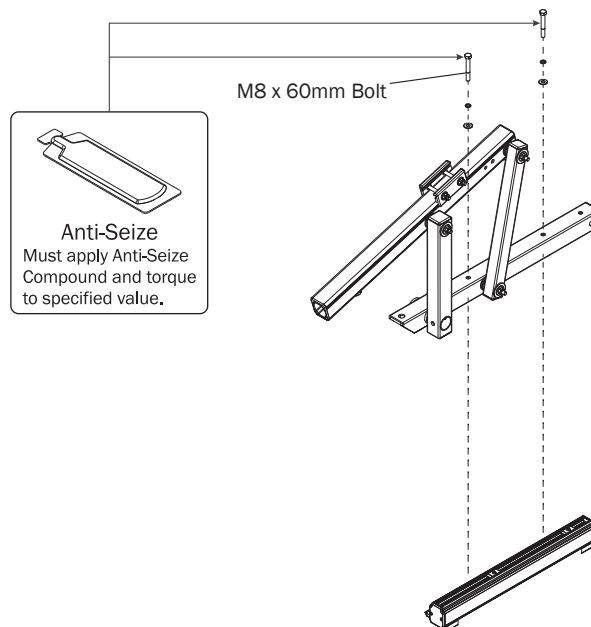

REAR DRIVE SHAFT

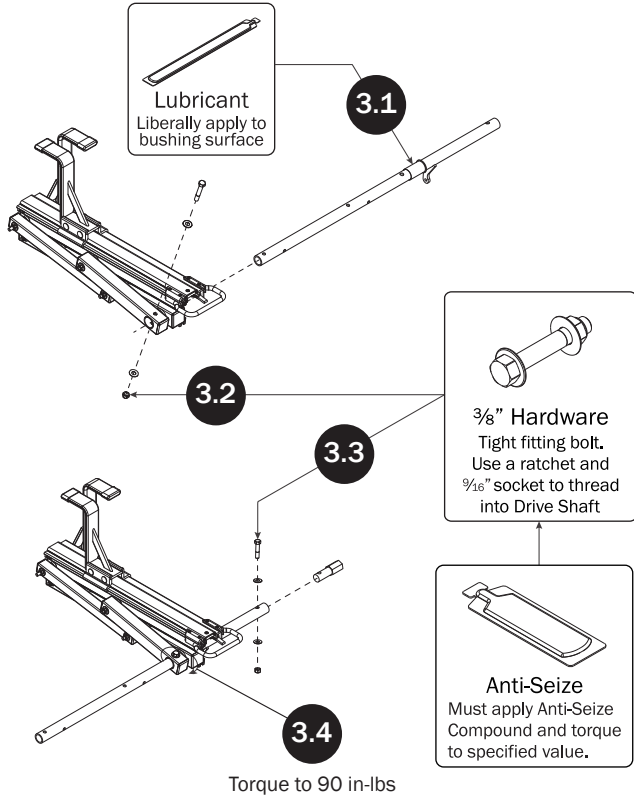

CYLINDER HARDWARE

NOTE: Adjusting the Cylinder's Flow Control screw by 1- $\frac{1}{2}$ turns left to default setting will release the Cylinder Rod making it easier to pull the rod toward the Drive Shaft's Cylinder Lever during installation.

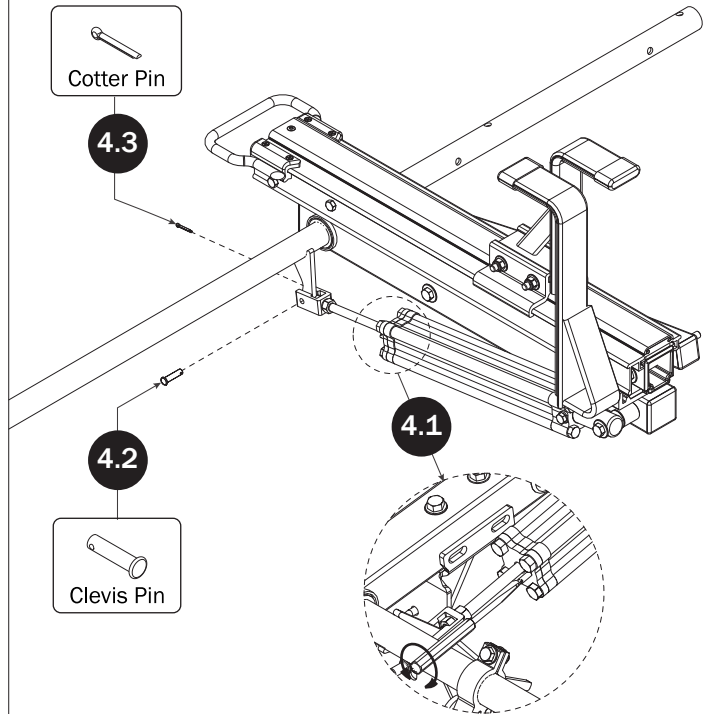

CONNECTING BAR

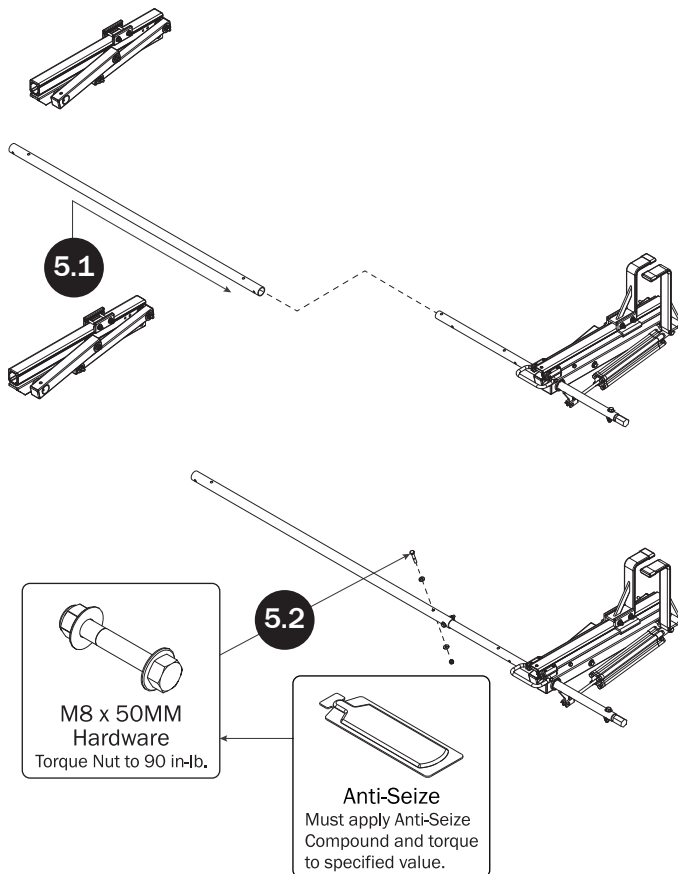

FRONT DRIVE SHAFT

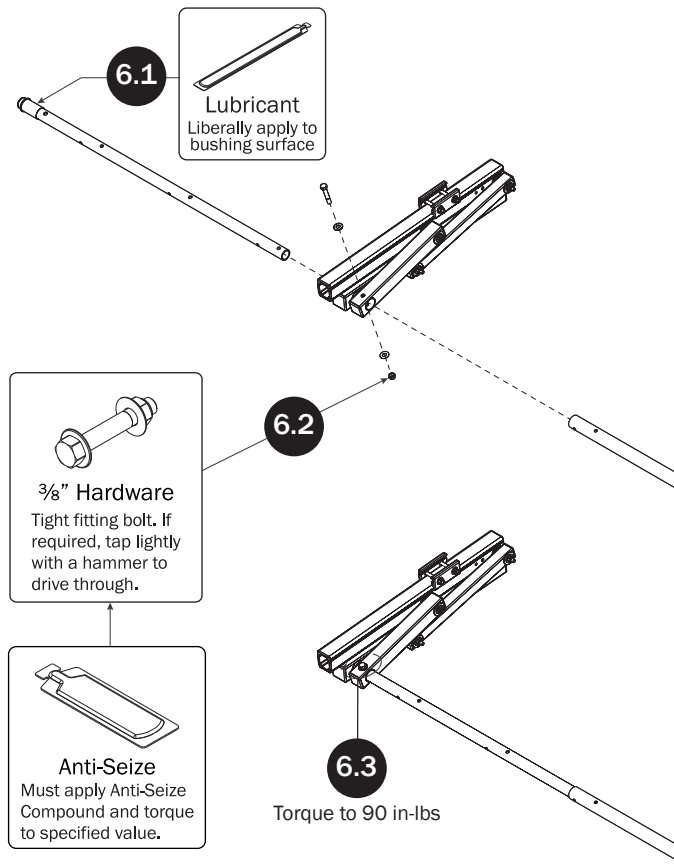

CONNECTING BAR FASTENERS

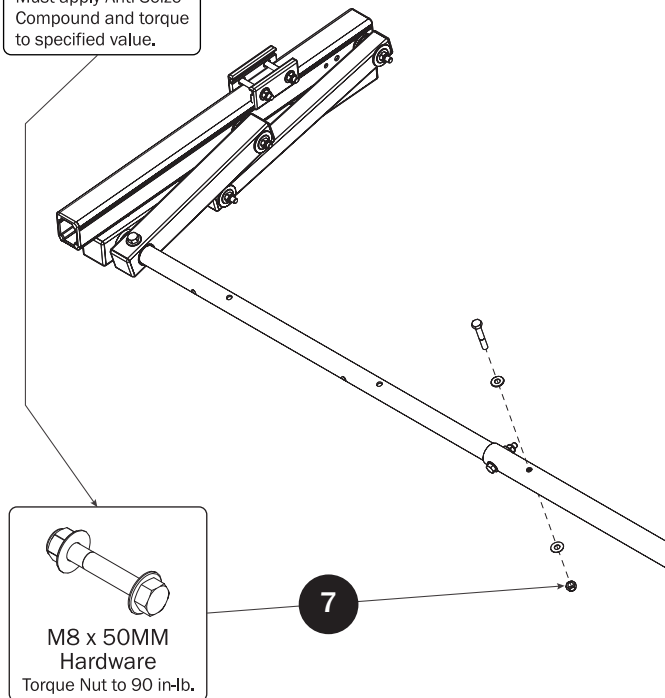

L POSTS

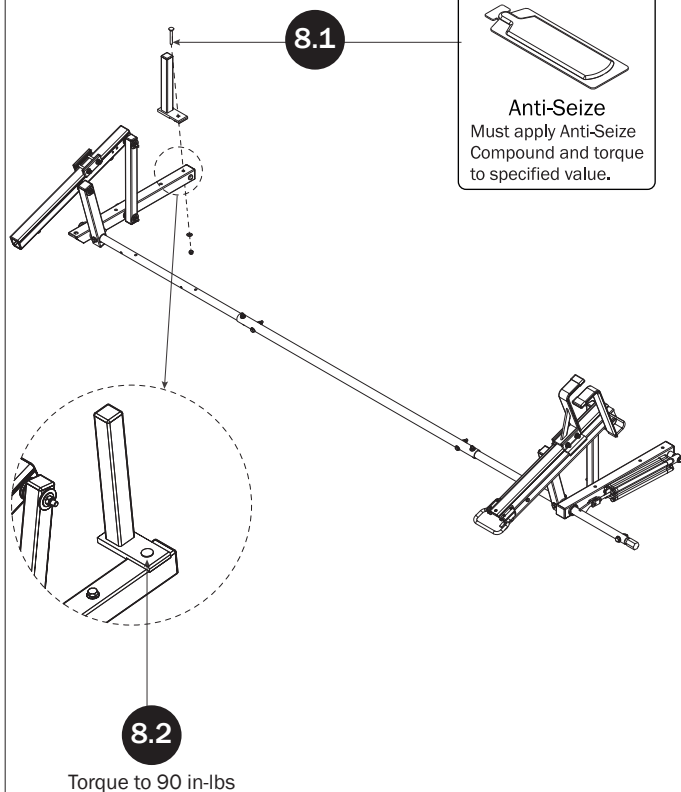

Z POSTS

SEE QUICK START GUIDE FOR ADJUSTMENTS

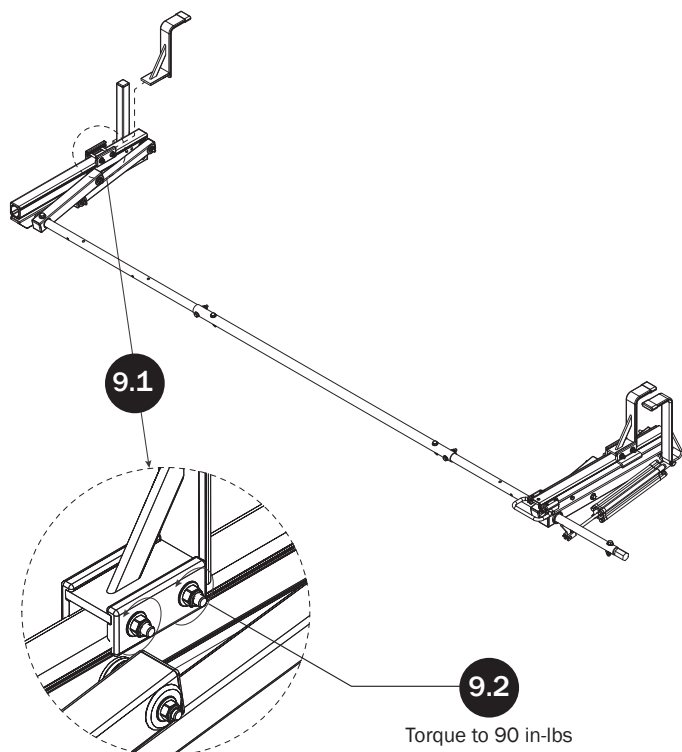

DRIVE SHAFT SEALING

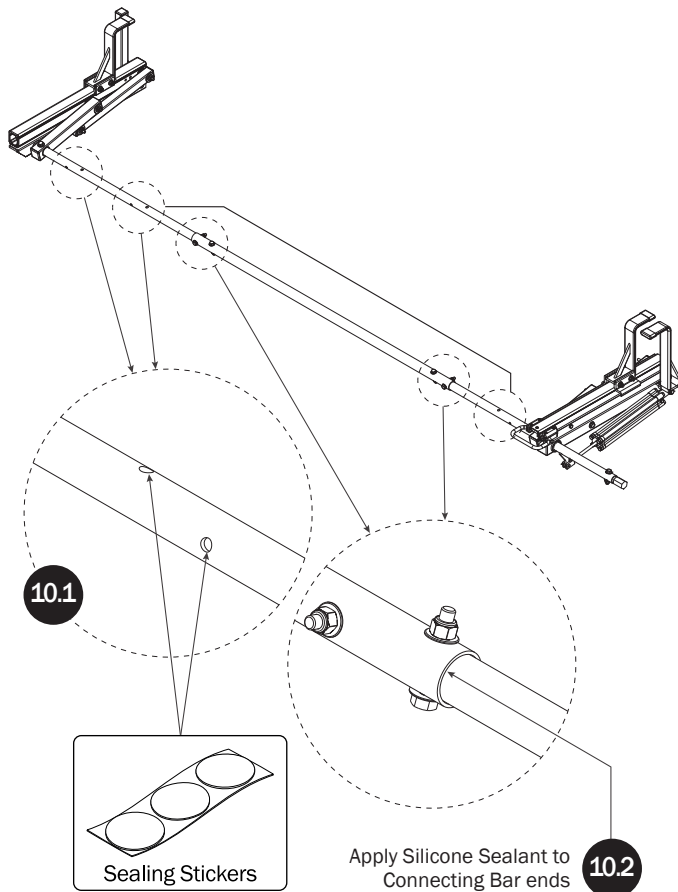

CYLINDER ADJUSTMENT

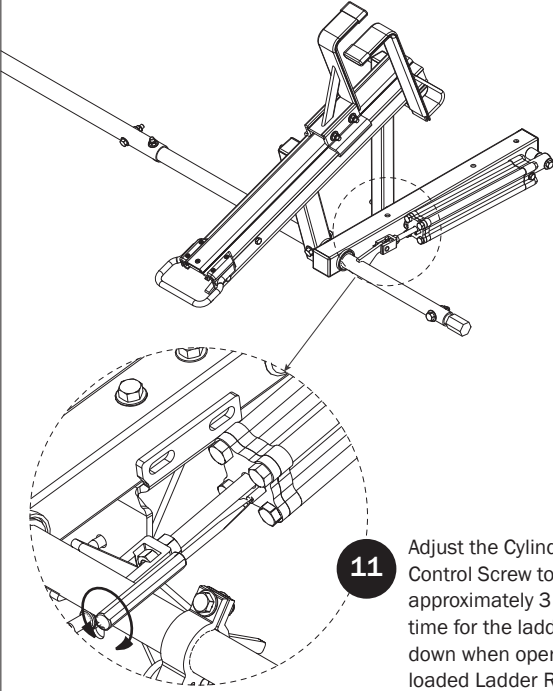

Adjust the Cylinder Flow Control Screw to allow approximately 3 seconds time for the ladder to glide down when operating the loaded Ladder Rack.

