

PRIME DESIGN™

A Safe Fleet Brand

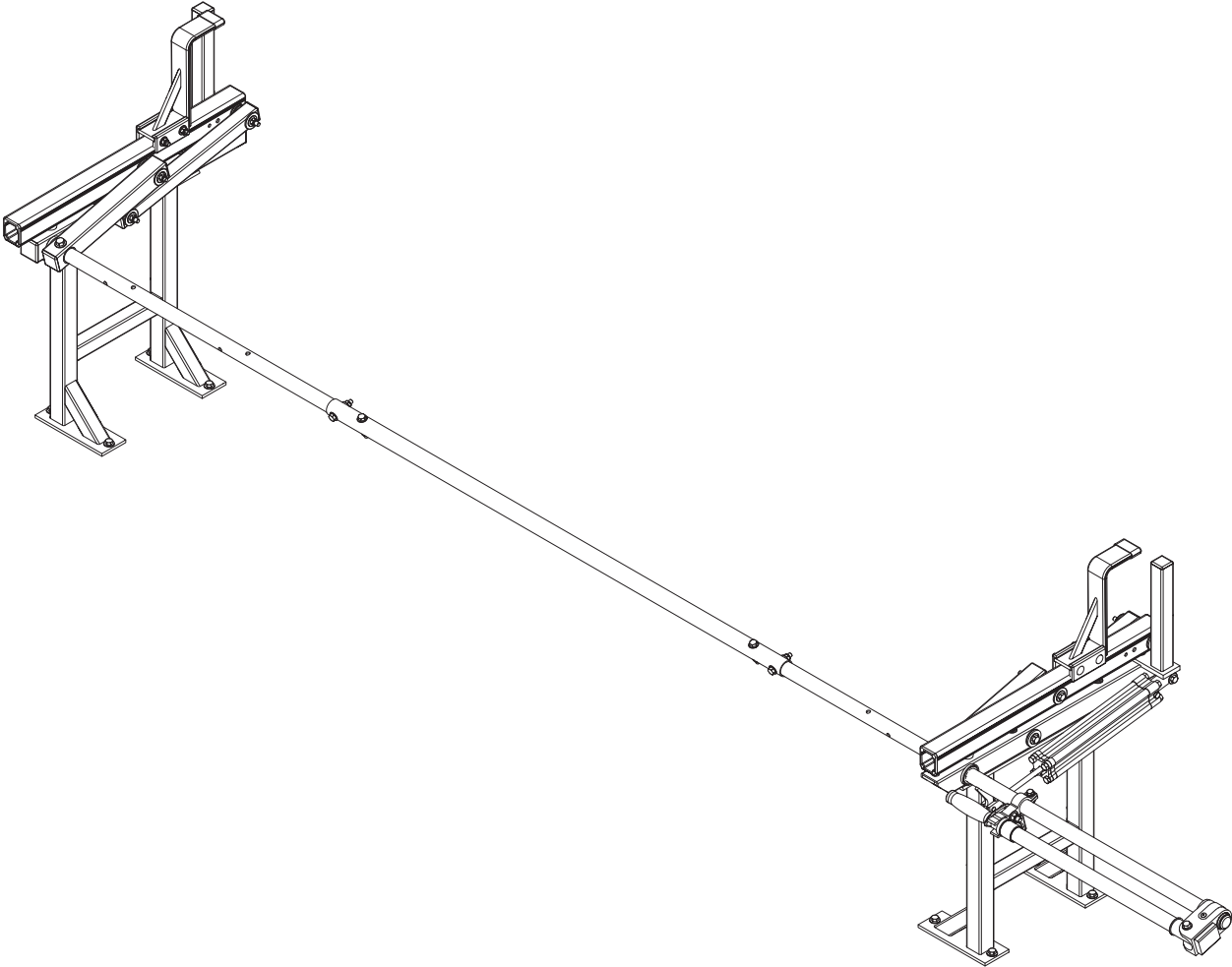

URX 001A

CONTENTS OVERVIEW

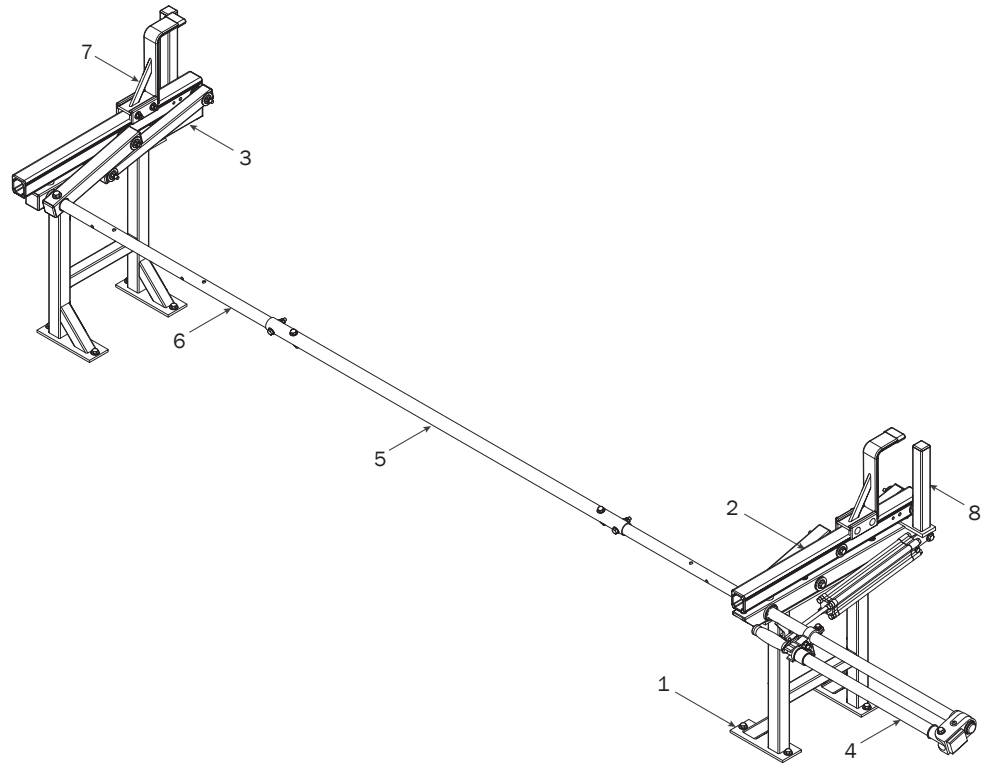

1—Utility Base Standing Mount..... (Qty 2)

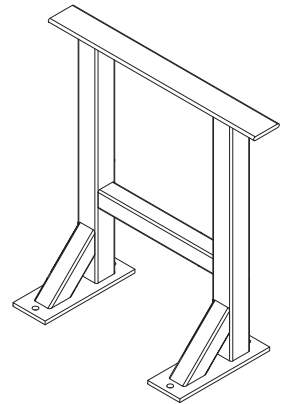

2—Rear Rotation Assembly..... (Qty 1)

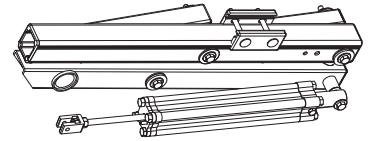

3—Front Rotation Assembly..... (Qty 1)

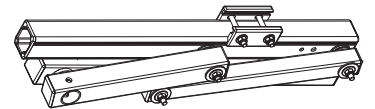

4—Rear Drive Shaft..... (Qty 1)
Left Hand, B4 Version, 50.00"

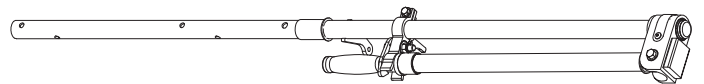

5—Connecting Bar..... (Qty 1)
48.00"

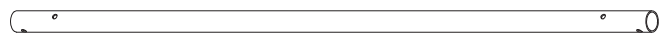

6—Front Drive Shaft..... (Qty 1)
B Version, 35.75"

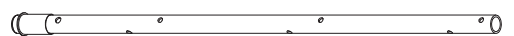

7-Z Post (Qty 2)
Adjustable, 7.25"

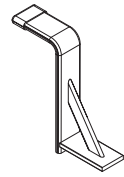

8-L Post (Qty 2)
9.25"

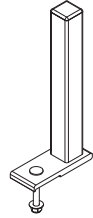

HKT-8163-Rotation Hardware Kit

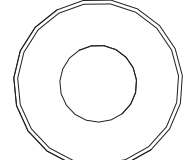
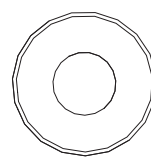
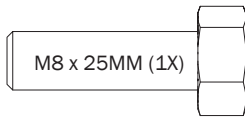
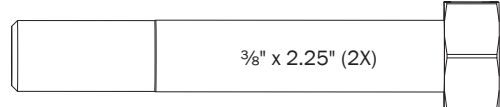

M8 Lock Nut (5X)

3/8" Lock Nut (2X)

5/16" Flat Washer (10X)

3/8" Flat Washer (4X)

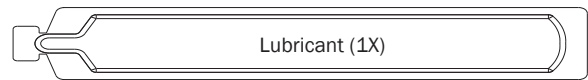
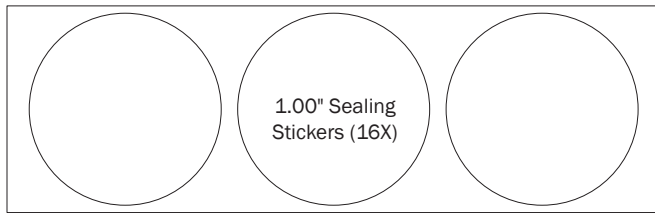

HKT-0122 Mounting Hardware Kit

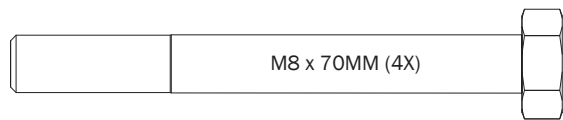
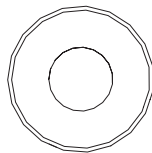
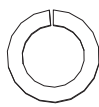
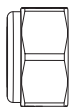

Lock Nut (12X)

Lock Washer (4X)

Flat Washer (8X)

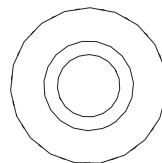
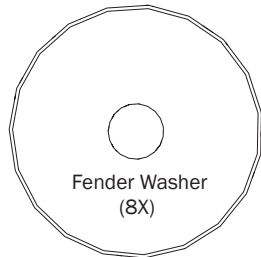

Neoprene Washer (8X)

Fender Washer (8X)

Sealing Washer (8X)

Anti-Seize (1X)



UTB-2316 MOUNTING BRACKETS
BRACKET PRE-ASSEMBLY

0.1

Drill holes into the service body mounting location according to dimensions shown for 8.00 ft rack configuration.

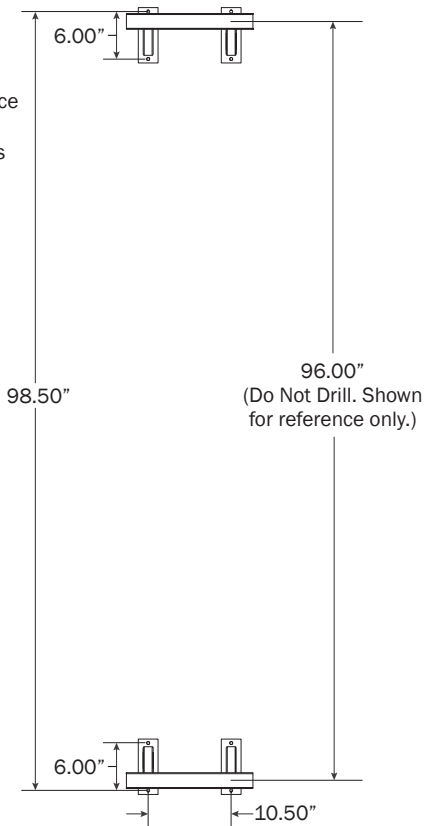

0.2

Dimensions shown below are for 5' (60.00"), 6' (72.00"), and 7' (84.00") spacing.

Dimensions A are measured from center to center of top mounting rail. Dimensions B are measured from outside bracket hole to outside bracket hole.

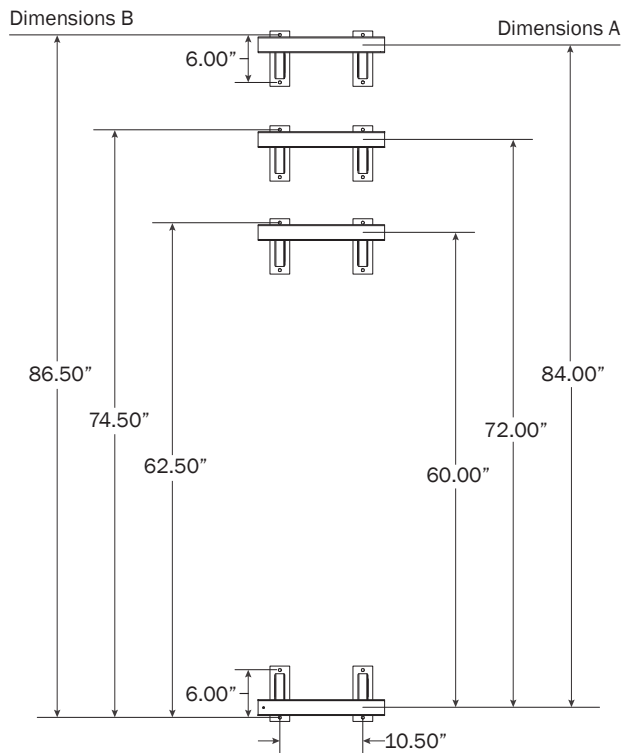

0.3

Apply Anti-Seize compound to Mounting Bracket bolts. The shorter bolt assemblies are on the outside as shown.

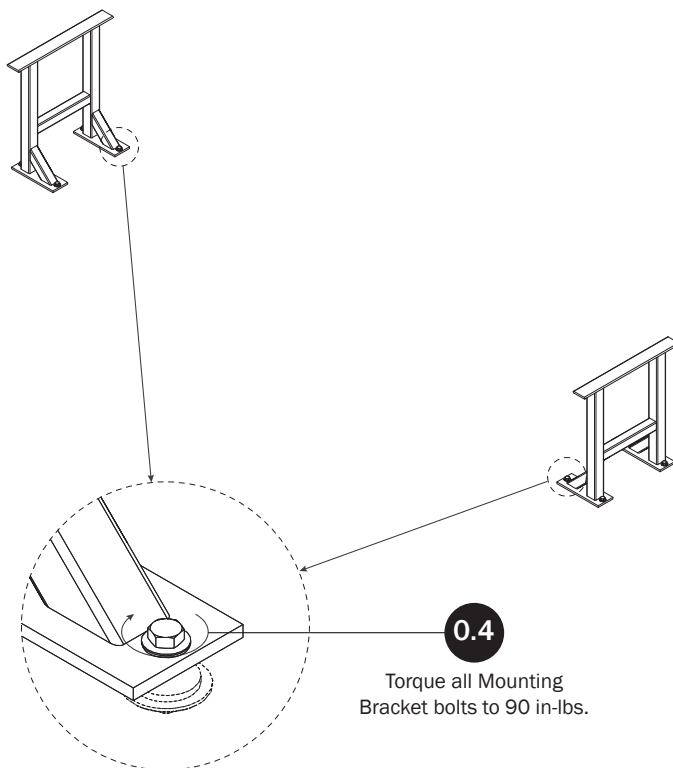
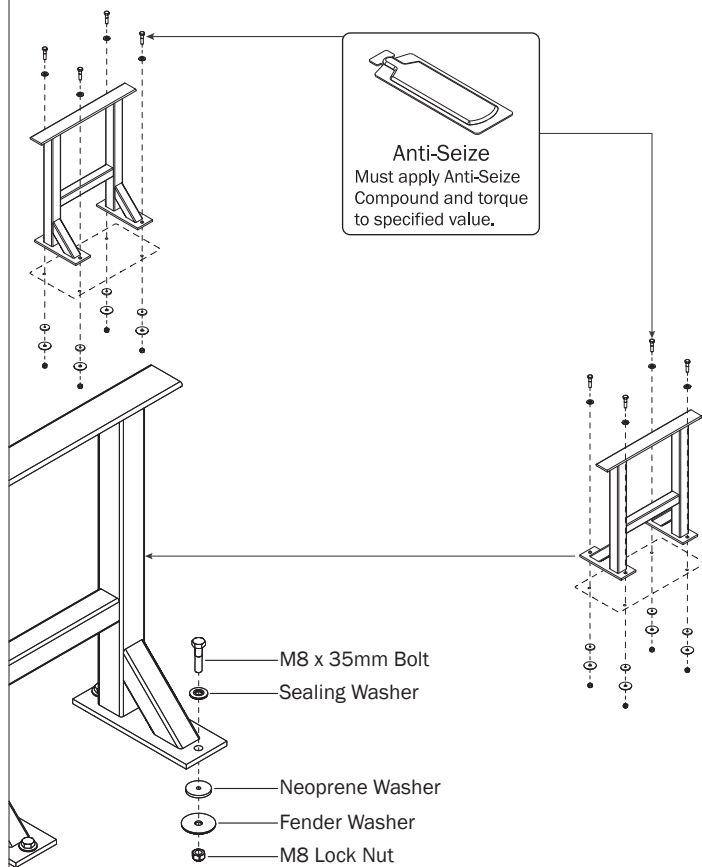

LEFT ROTATION ASSEMBLY SEQUENCE

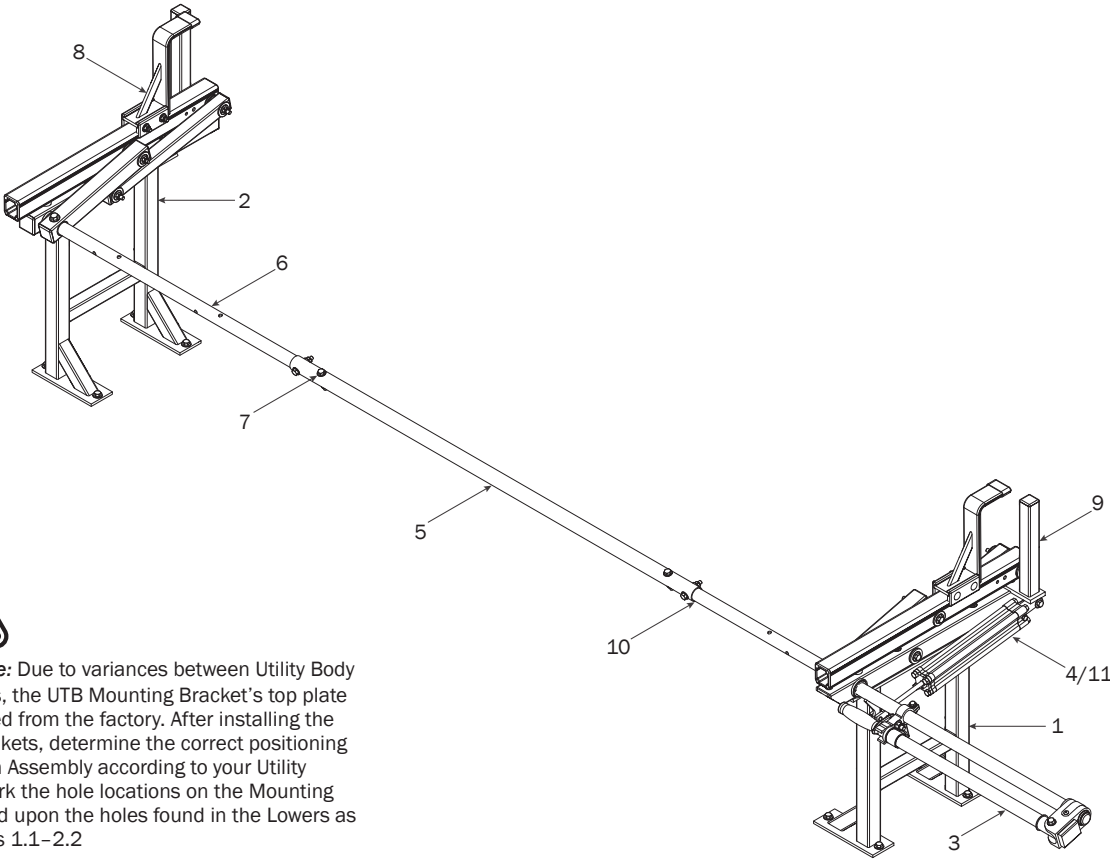

Installer's Note: Due to variances between Utility Body manufacturers, the UTB Mounting Bracket's top plate comes undrilled from the factory. After installing the Mounting Brackets, determine the correct positioning of the Rotation Assembly according to your Utility Body, then mark the hole locations on the Mounting Brackets based upon the holes found in the Lowers as shown in Steps 1.1-2.2

REAR ROTATION ASSEMBLY

FRONT ROTATION ASSEMBLY

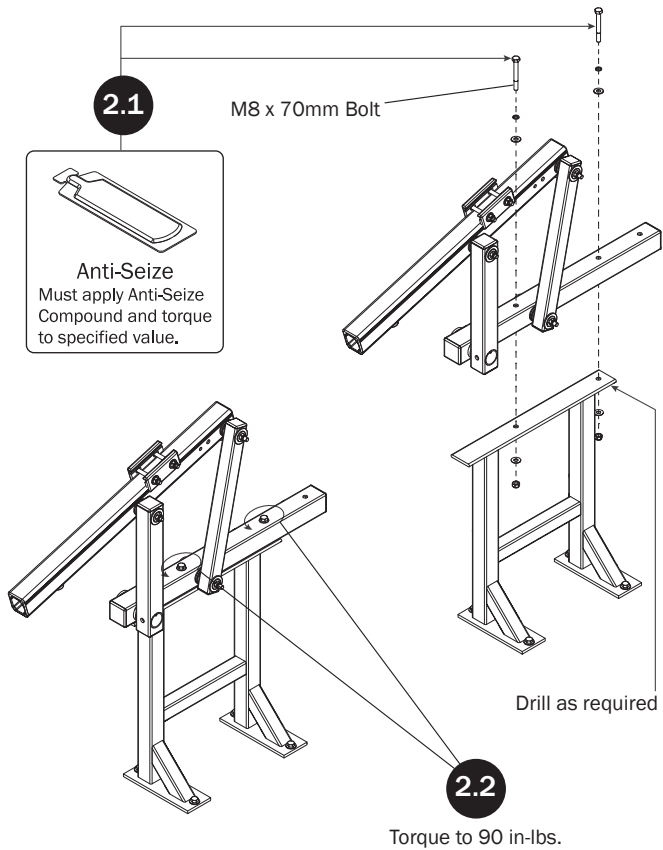
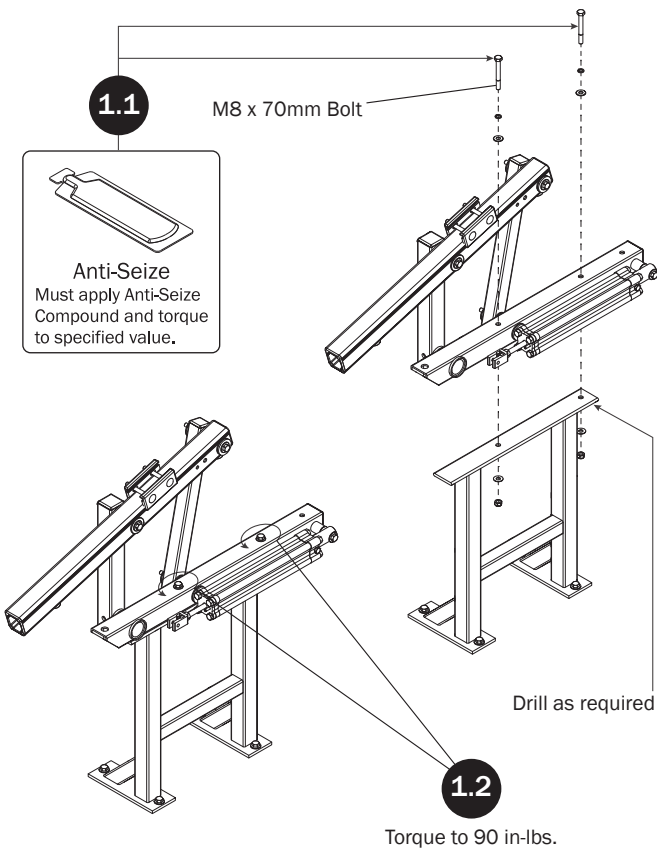

REAR DRIVE SHAFT

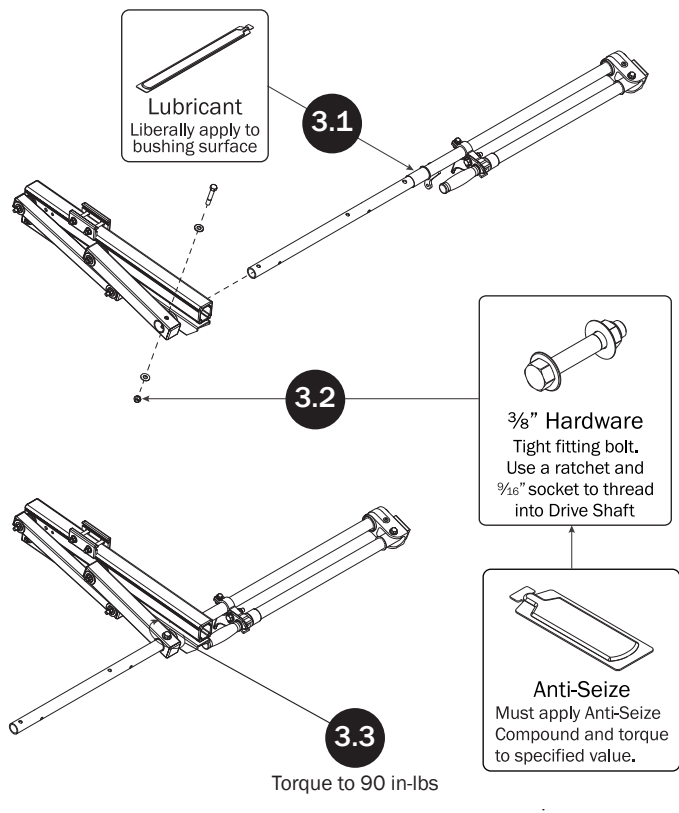

CYLINDER HARDWARE

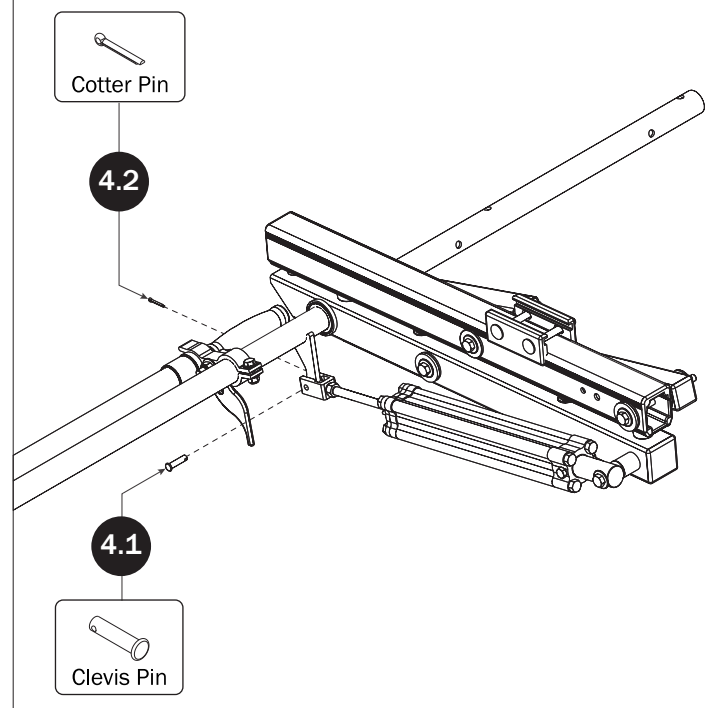

CONNECTING BAR

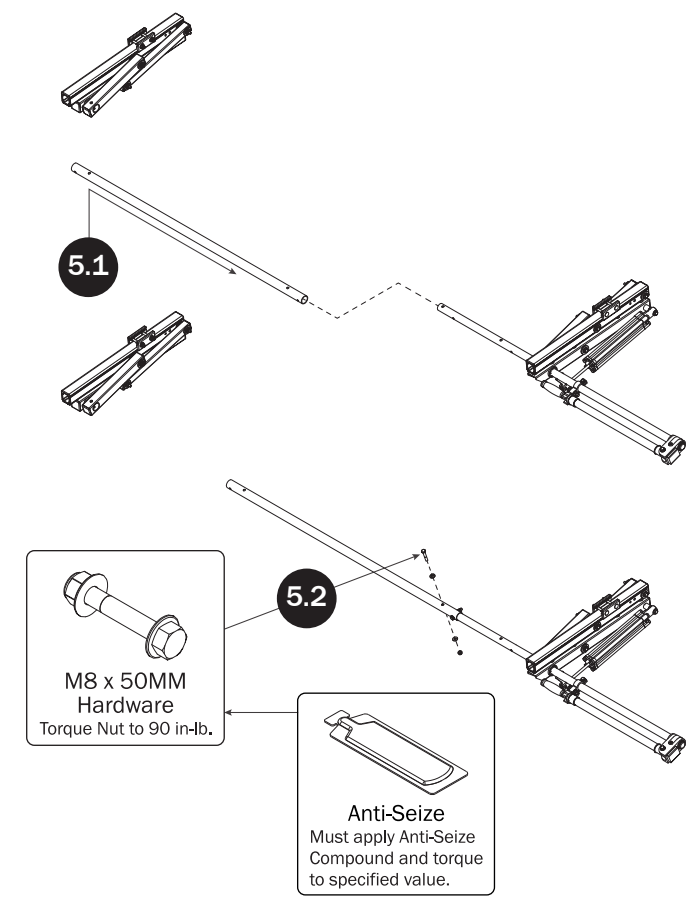

FRONT DRIVE SHAFT

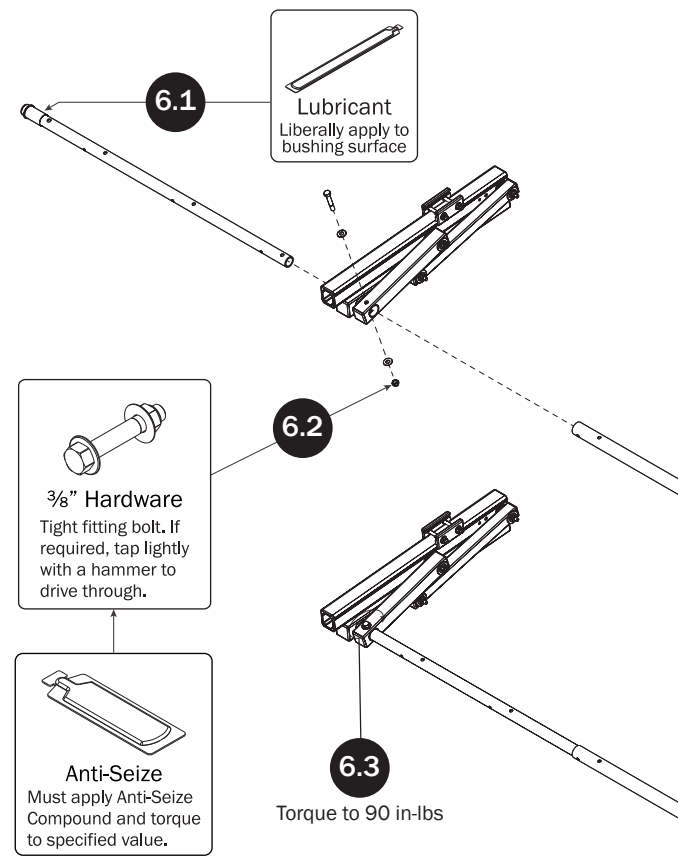

CONNECTING BAR FASTENERS

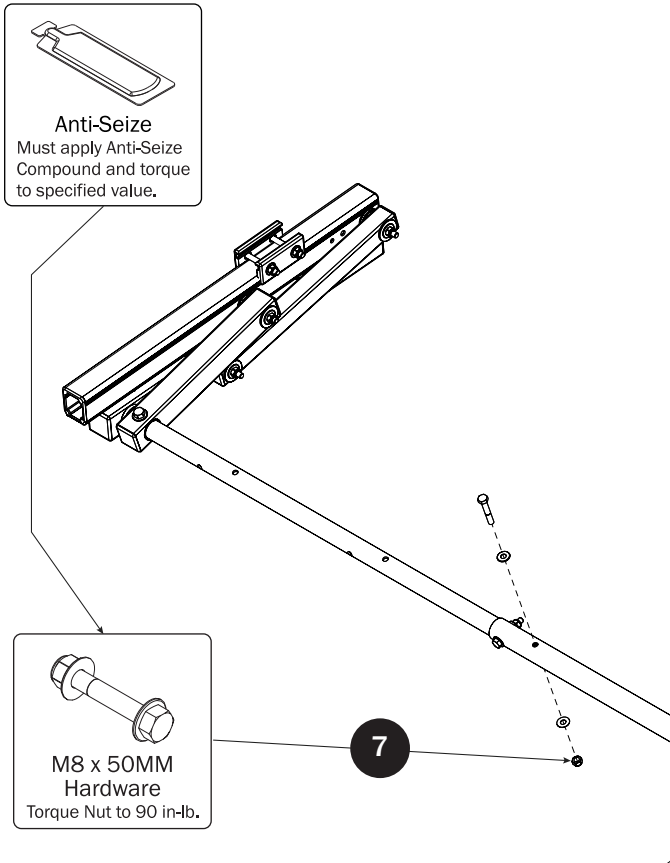

L POSTS

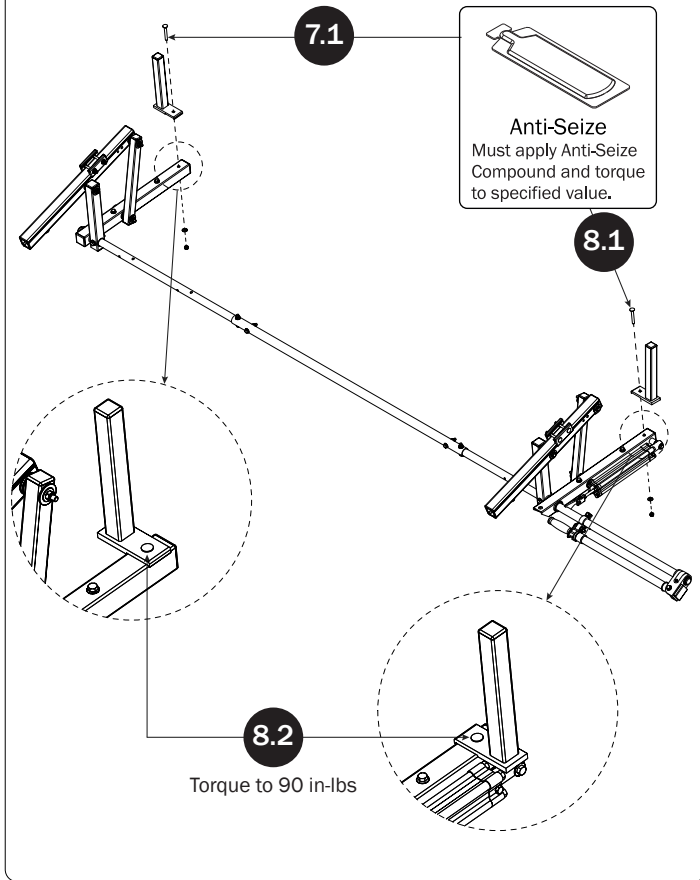

Z POSTS

SEE QUICK START GUIDE FOR ADJUSTMENTS

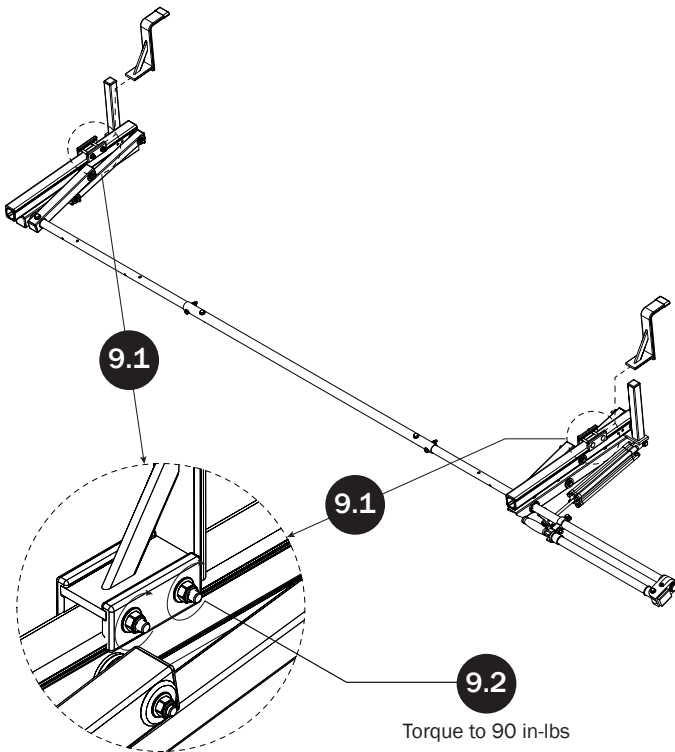

DRIVE SHAFT SEALING

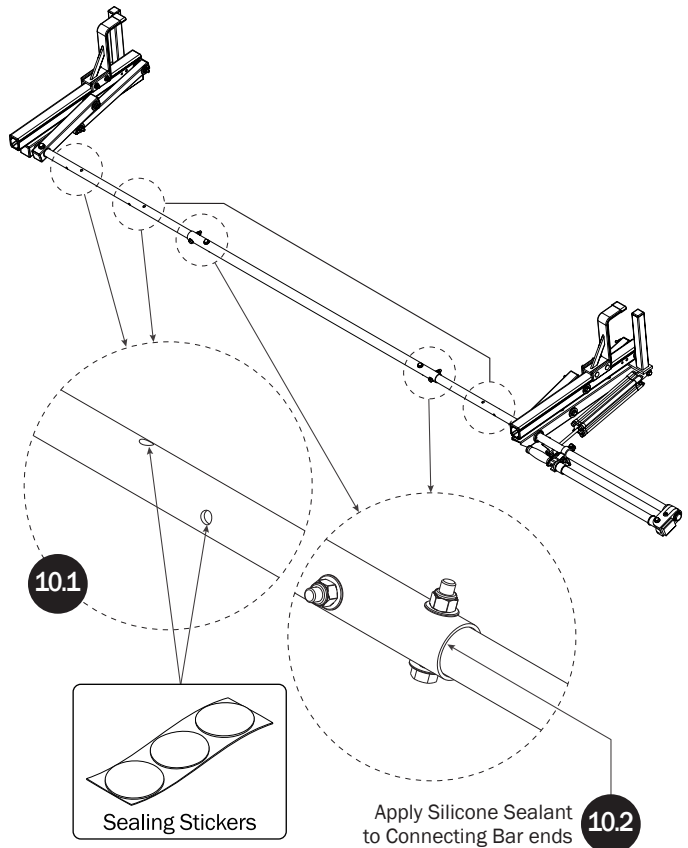

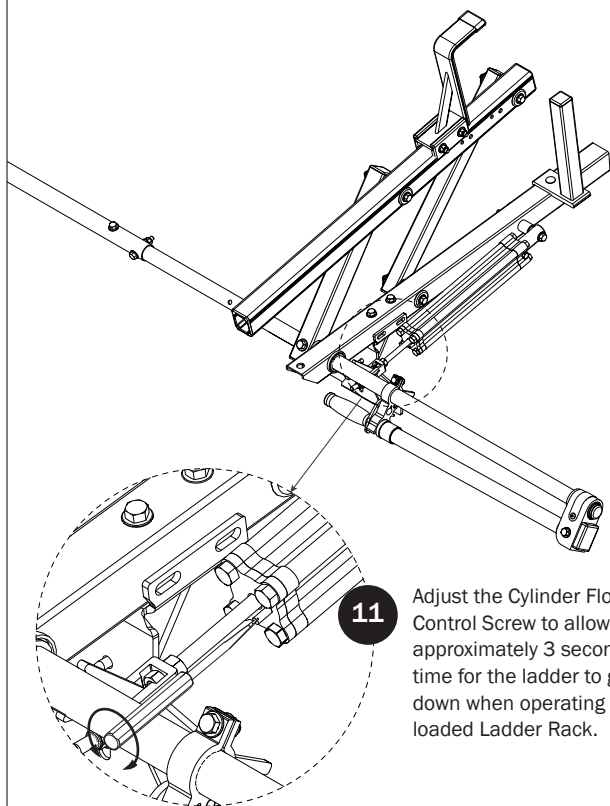
CYLINDER ADJUSTMENT**11**

Adjust the Cylinder Flow Control Screw to allow approximately 3 seconds time for the ladder to glide down when operating the loaded Ladder Rack.

USAM-URX001E-US01 Rev-C 0618