

PRIME DESIGN™

A Safe Fleet Brand

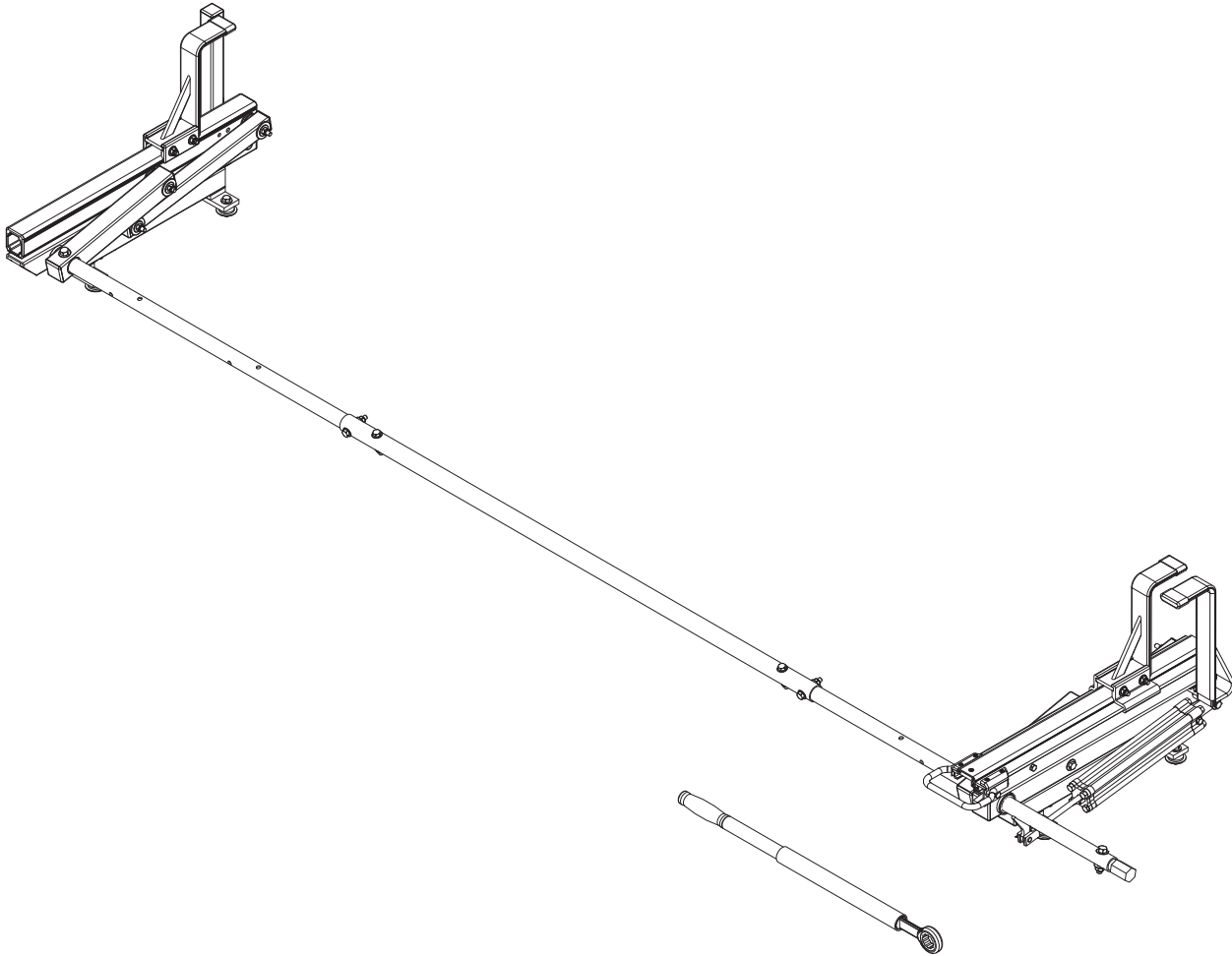

URX
0005

PRIME DESIGN, A SAFE FLEET BRAND

Address: 580 Opperman Drive, Eagan, MN 55123 • Toll Free: 1.8.PRIME.RACK
Fax: 651-552-1799 • Email: info@primedesign.net • Website: www.primedesign.net

CONTENTS OVERVIEW

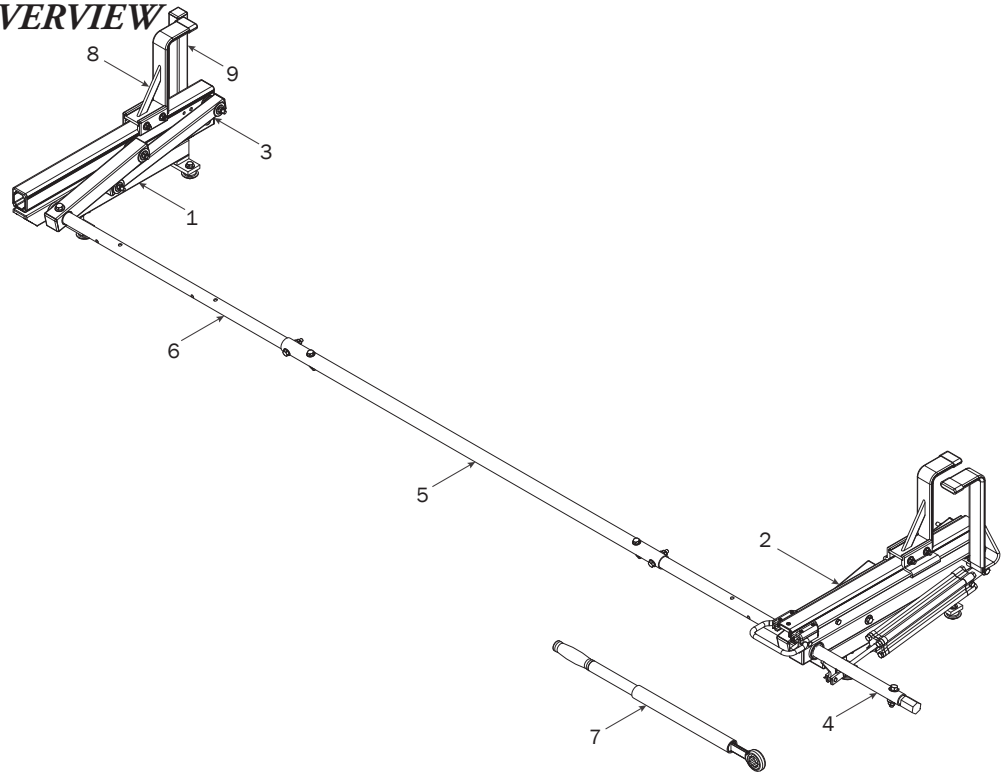

1—Utility Base Standing Mount..... (Qty 2)

2—Rear Rotation Assembly..... (Qty 1)

3—Front Rotation Assembly..... (Qty 1)

4—Rear Drive Shaft..... (Qty 1)
Left Hand, B4 Version, 50.00”

5—Connecting Bar..... (Qty 1)
48.00”

6—Front Drive Shaft (Qty 1)
B Version, 35.75”

7—Ratcheting Handle Assembly (Qty 1)
With Hardware

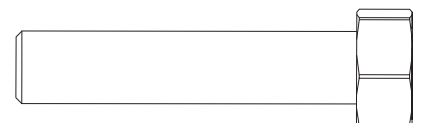
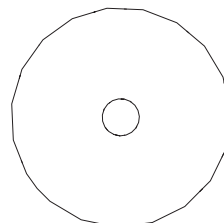
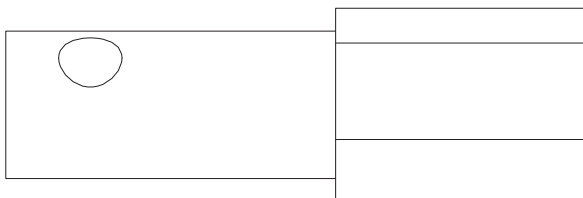
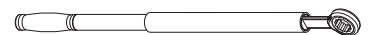
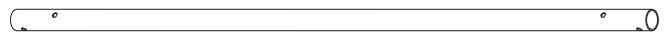
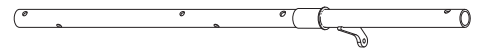
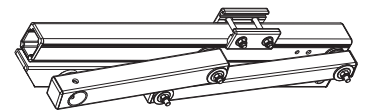
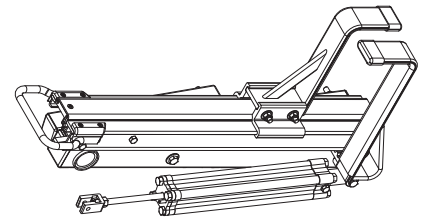
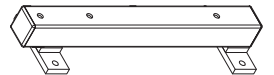

8-Z Post (Qty 1)
Adjustable, 7.25"

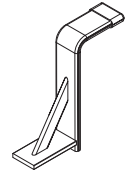

9-L Post (Qty 1)
9.25"

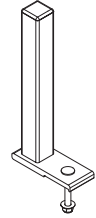

HKT-8163-Rotation Hardware Kit

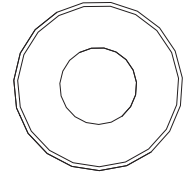
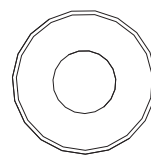
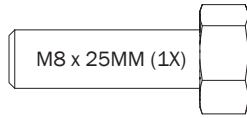
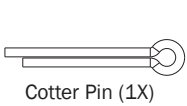
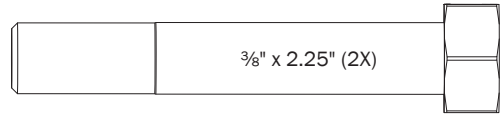
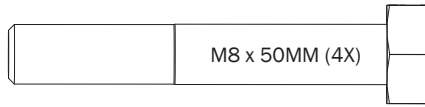

M8 Lock Nut (5X)

3/8" Lock Nut (2X)

5/16" Flat Washer (10X)

3/8" Flat Washer (4X)

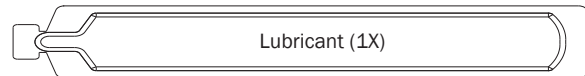
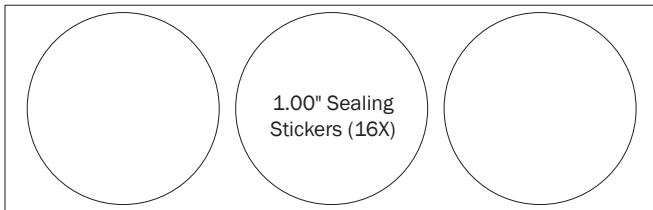

HKT-0122 Mounting Hardware Kit

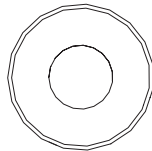
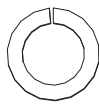
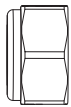

Lock Nut (12X)

Lock Washer (4X)

Flat Washer (8X)

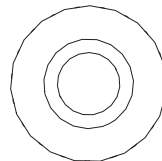
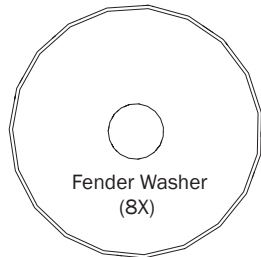

Neoprene Washer (8X)

Fender Washer (8X)

Sealing Washer (8X)

M8 x 35MM (8X)



Anti-Seize (1X)

UTB-2316 MOUNTING BRACKETS
BRACKET PRE-ASSEMBLY

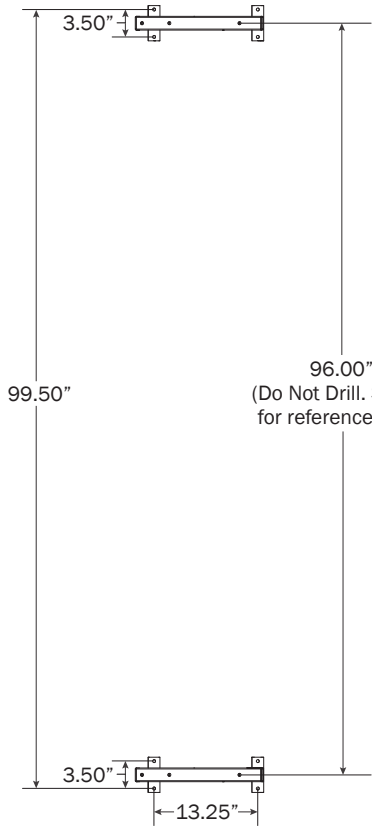

0.1 Drill holes into the Service Body mounting location according to dimensions shown for 8.00 ft rack configuration.

0.2 Dimensions shown below are for 5' (60.00"), 6' (72.00"), and 7' (84.00") spacing.

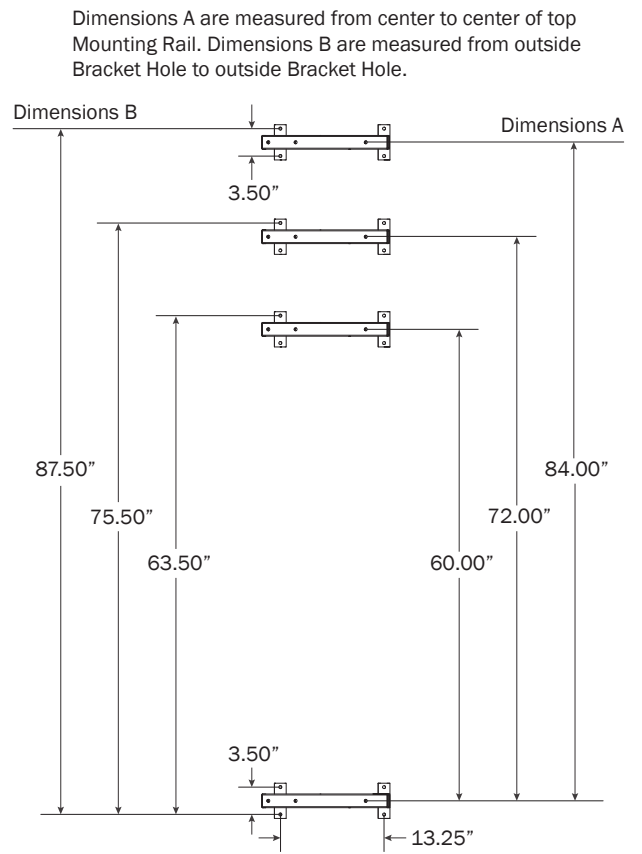

0.3 Apply Anti-Seize compound to Mounting Bracket bolts. The shorter bolt assemblies are on the outside as shown.

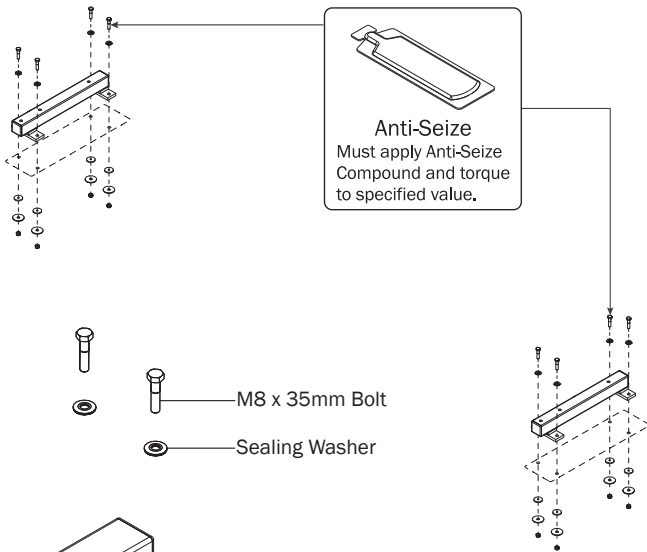

- M8 x 35mm Bolt
- Sealing Washer

- Neoprene Washer
- Fender Washer
- M8 Lock Nut

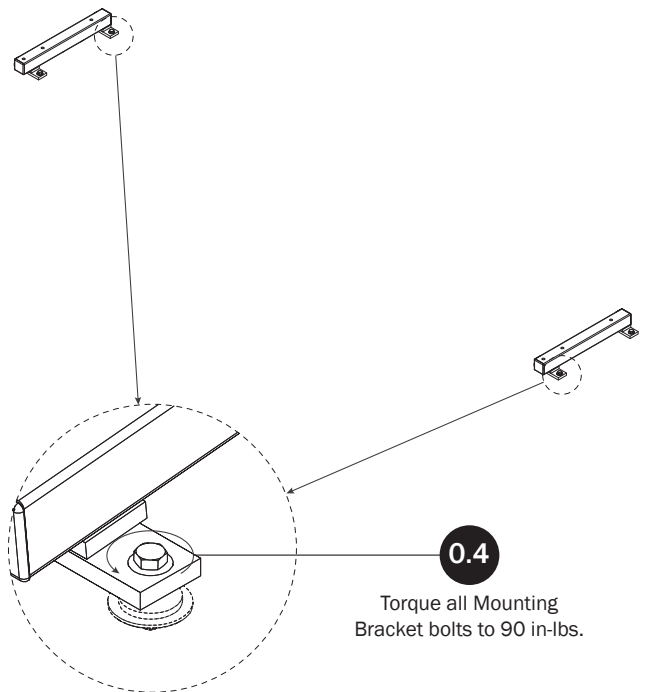

RIGHT ROTATION ASSEMBLY SEQUENCE

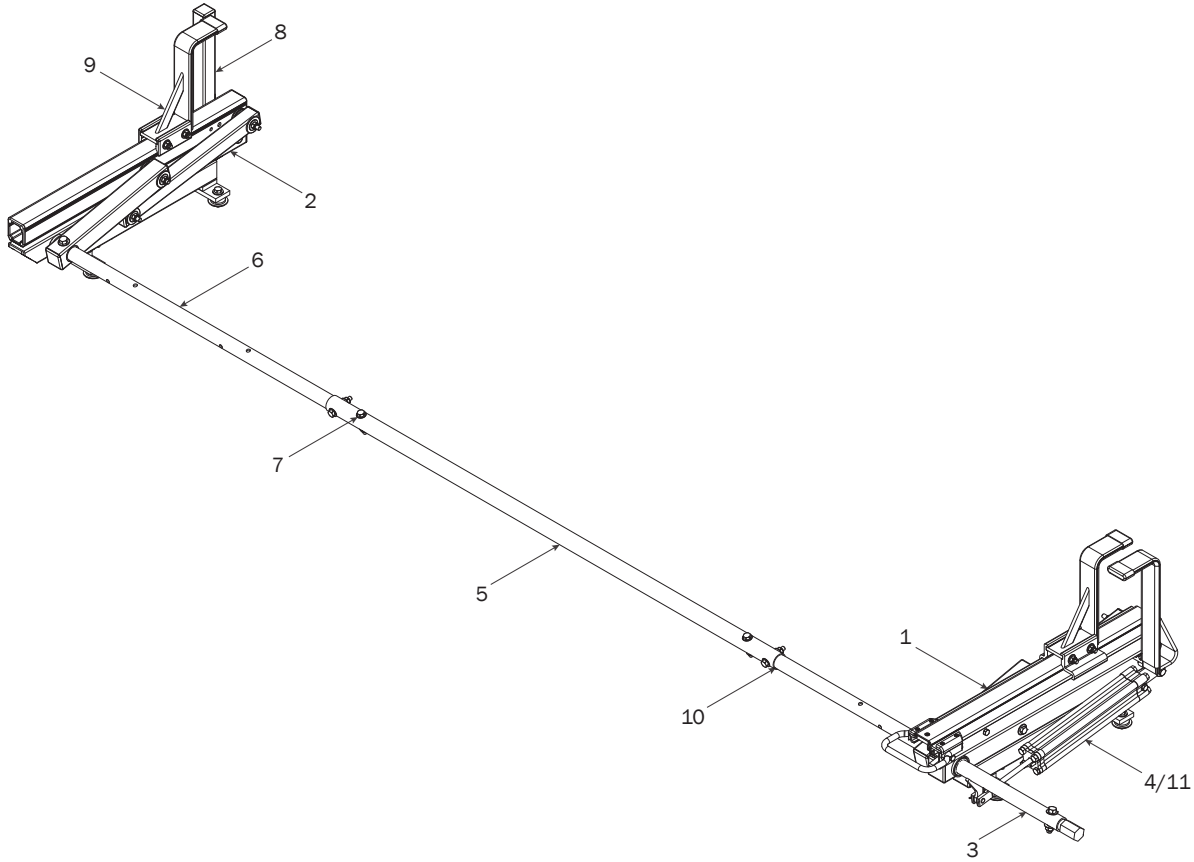

REAR ROTATION ASSEMBLY

Torque to 90 in-lbs.

1

M8 x 110mm Bolt

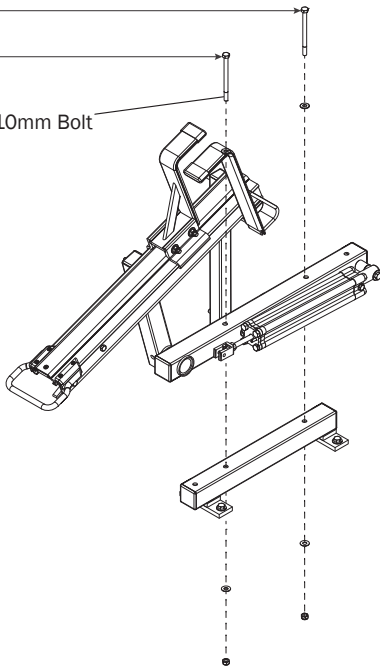

FRONT ROTATION ASSEMBLY

Torque to 90 in-lbs.

2

M8 x 110mm Bolt

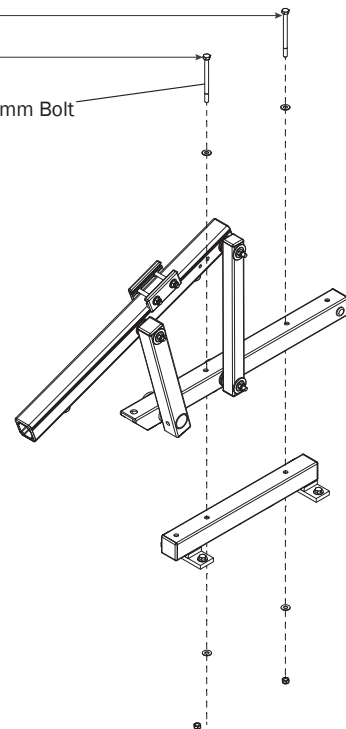

REAR DRIVE SHAFT

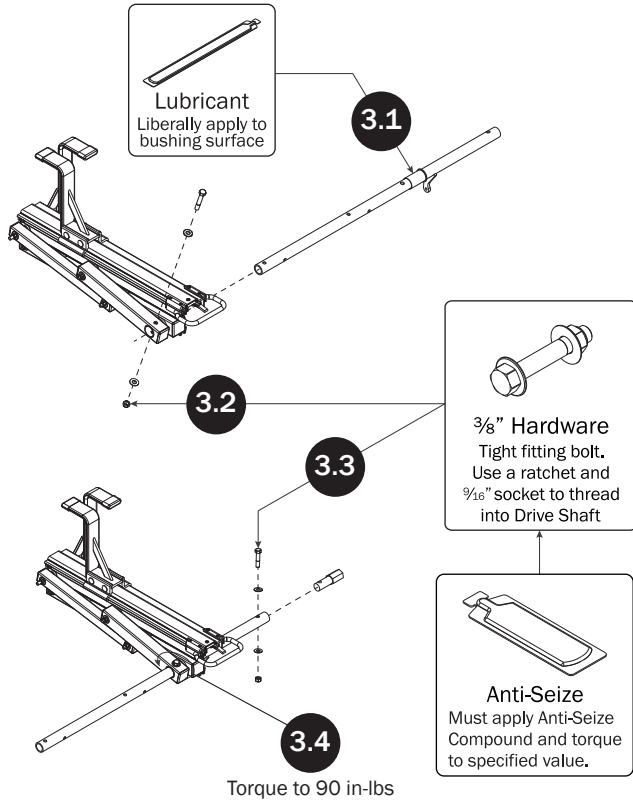

CYLINDER HARDWARE

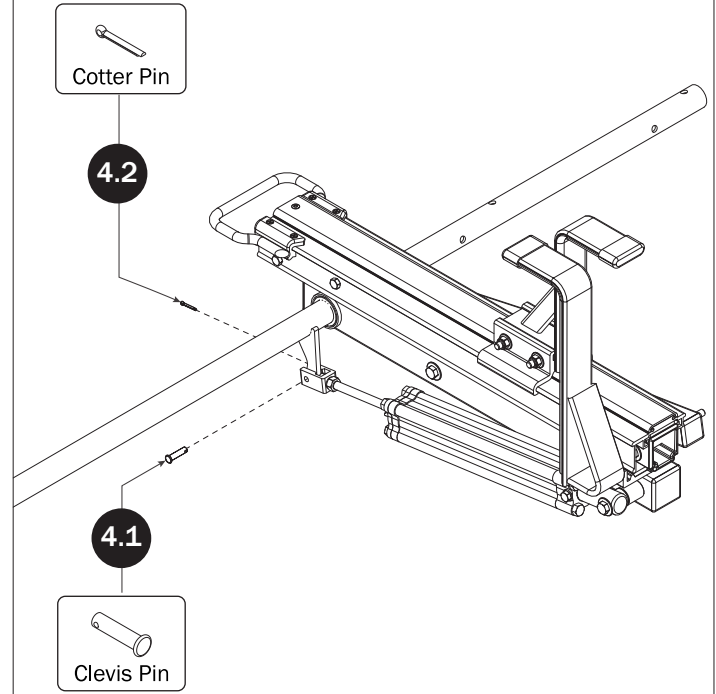

CONNECTING BAR

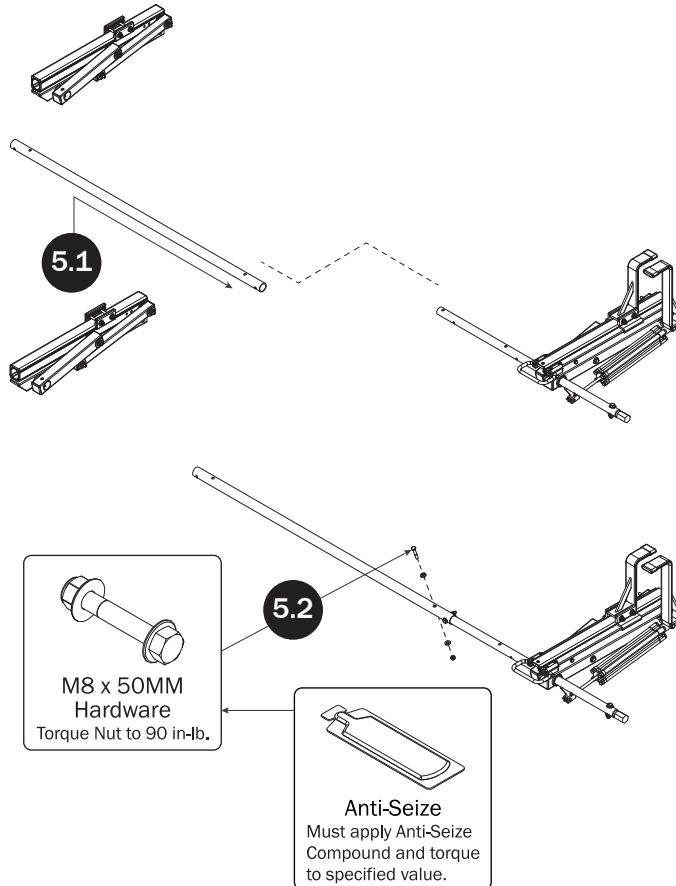

FRONT DRIVE SHAFT

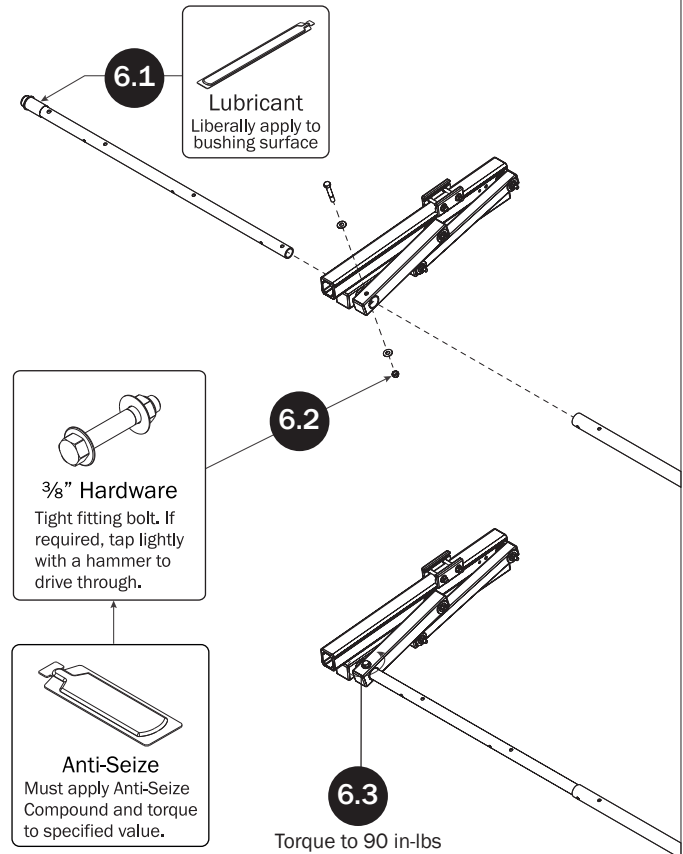

CONNECTING BAR FASTENERS

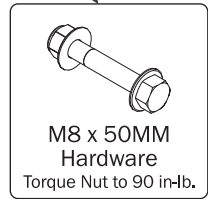
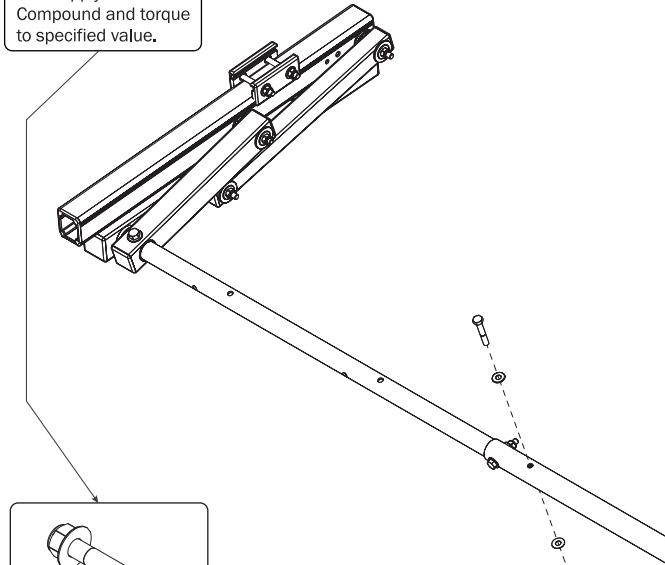

7

L POSTS

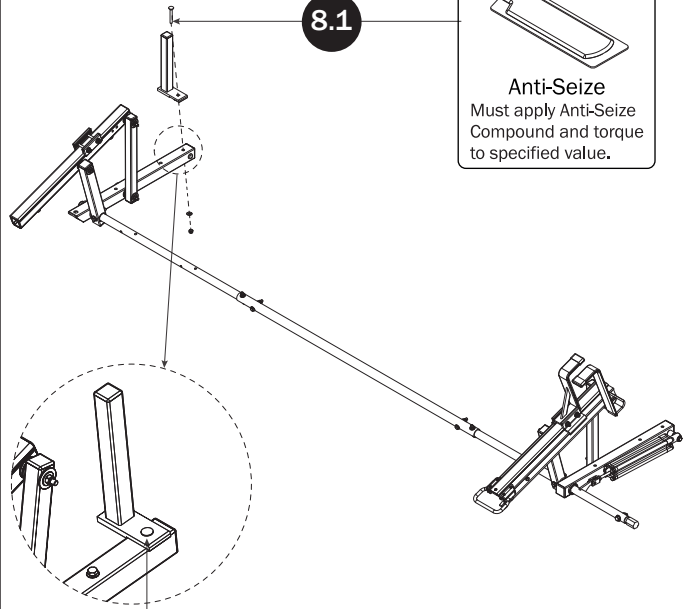
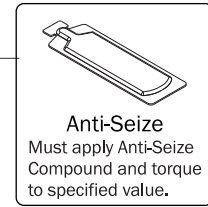

8.1

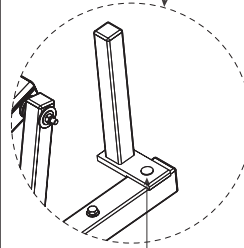

8.2

Torque to 90 in-lbs

Z POSTS

SEE QUICK START GUIDE FOR ADJUSTMENTS

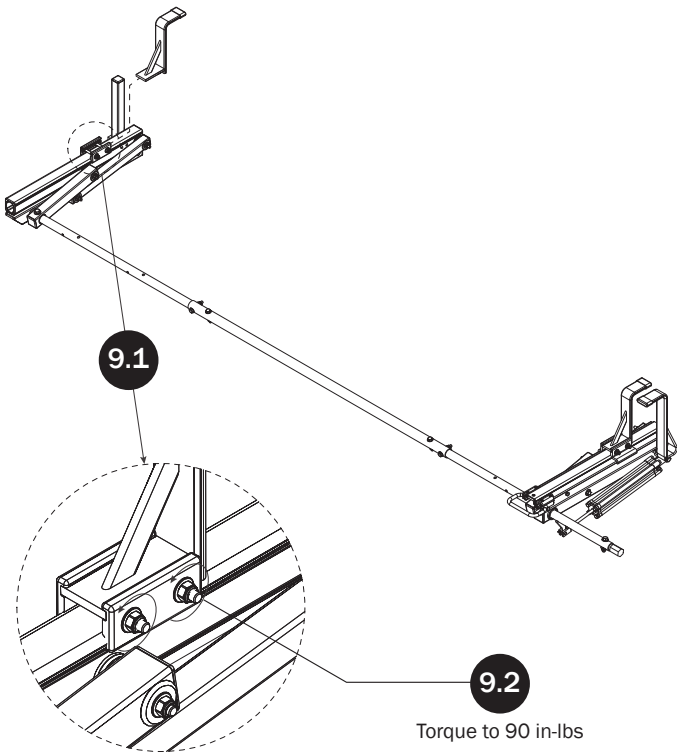

9.1

9.2

Torque to 90 in-lbs

DRIVE SHAFT SEALING

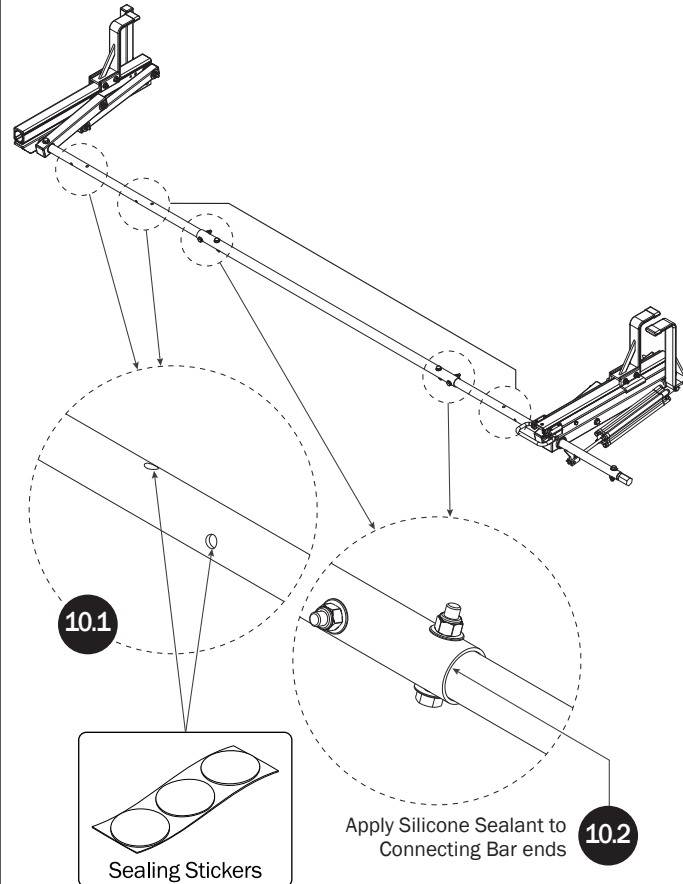

10.1

10.2

Apply Silicone Sealant to Connecting Bar ends

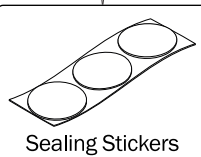

CYLINDER ADJUSTMENT

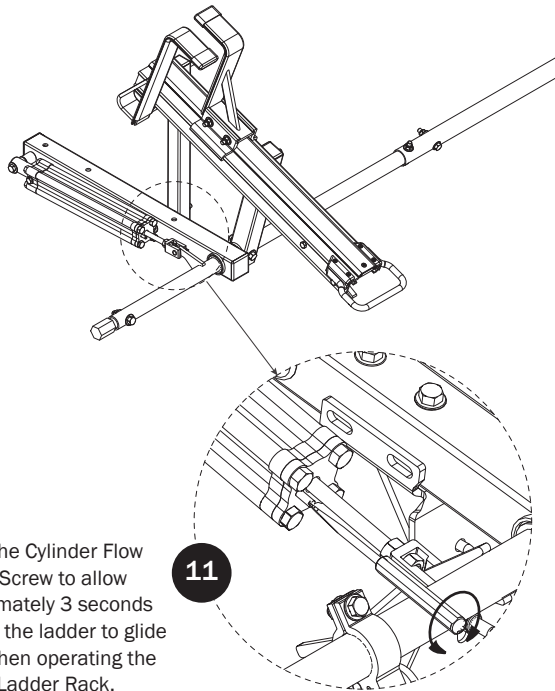

Adjust the Cylinder Flow Control Screw to allow approximately 3 seconds time for the ladder to glide down when operating the loaded Ladder Rack.

USAM-URX0005-US01 Rev-A 0618