

# PRIME DESIGN™

A Safe Fleet Brand

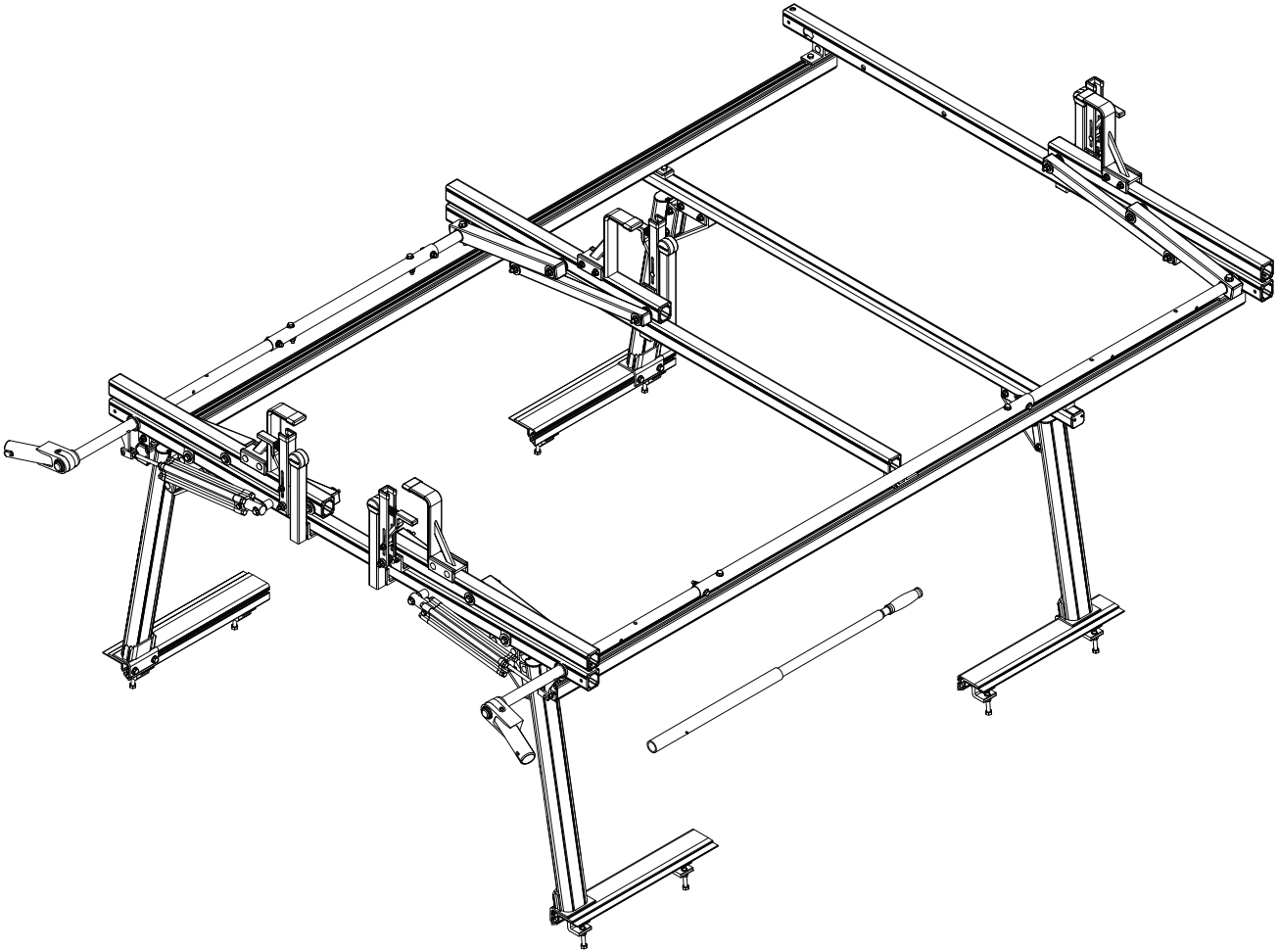

PRR3

CONTENTS OVERVIEW

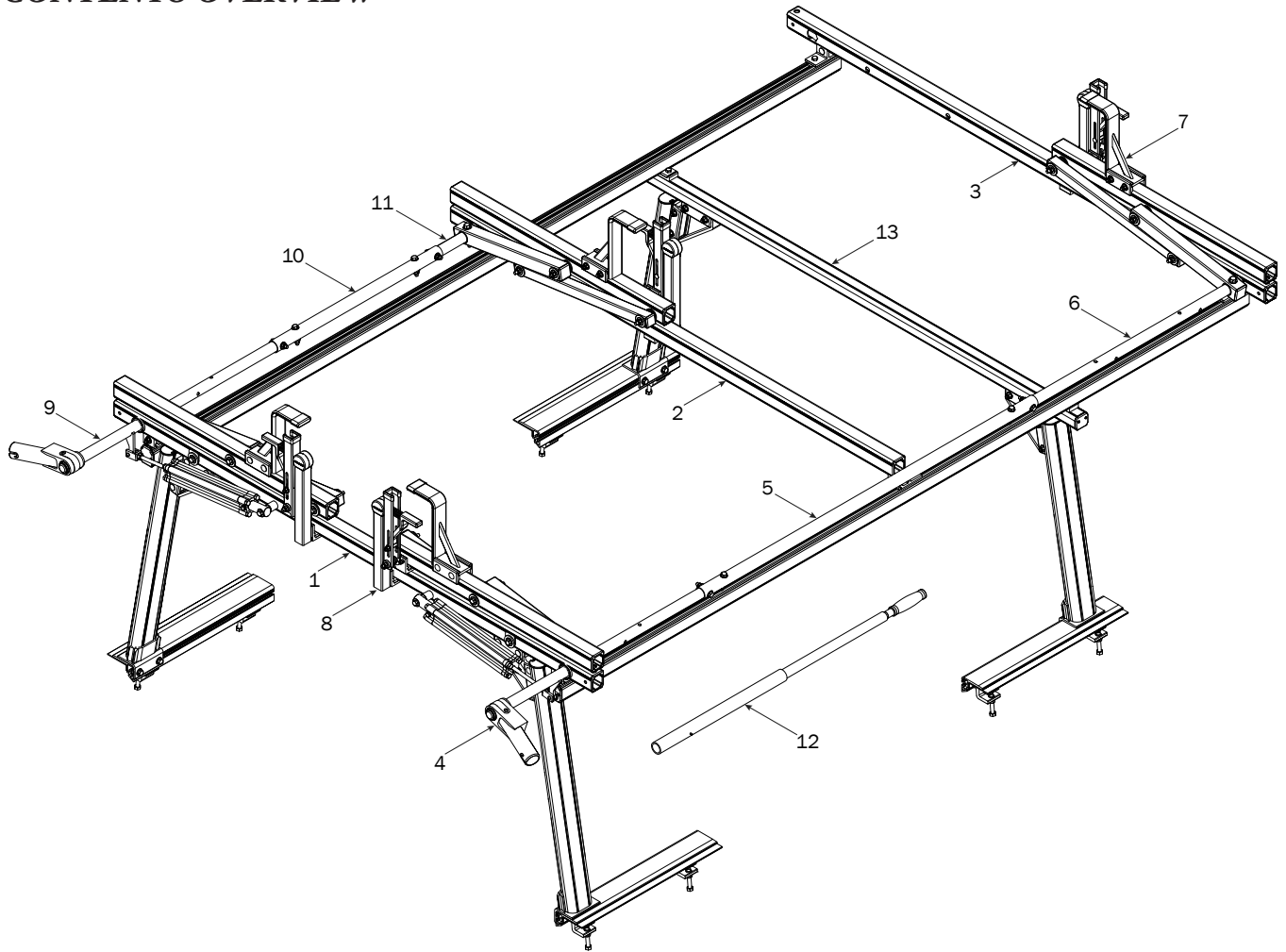

1—Rear Crossbar Assembly..... (Qty 1)

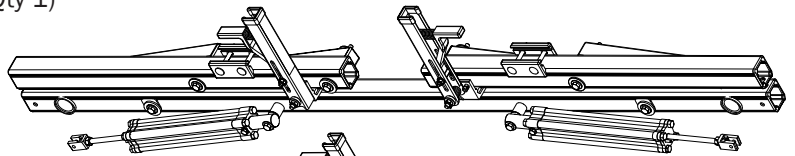

2—Center Crossbar Assembly..... (Qty 1)

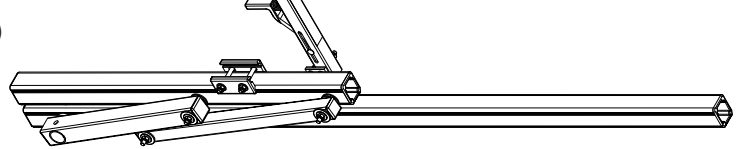

3—Front Crossbar Assembly ..... (Qty 1)

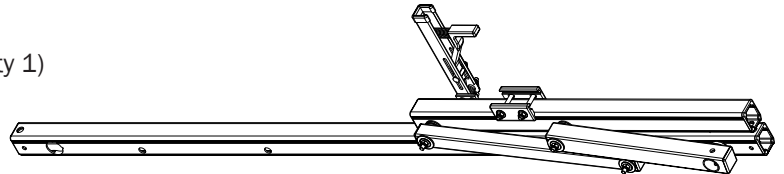

4—Rear Drive Shaft..... (Qty 1)  
Right Hand, Ver B5, 34.00”

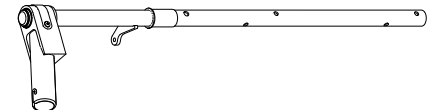

5—Connecting Bar..... (Qty 1)  
48.00”

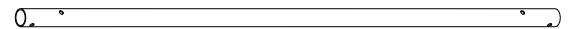

6—Front Drive Shaft..... (Qty 1)  
B Version, 35.75”

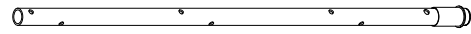

7—Z Post..... (Qty 4)  
Adjustable, 7.25”

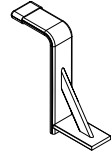

8—L Post..... (Qty 4)  
Gen4, Auto Clamp, 9.25”

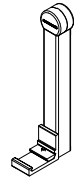

9—Rear Drive Shaft..... (Qty 1)  
Left Hand, Ver B5, 34.00”

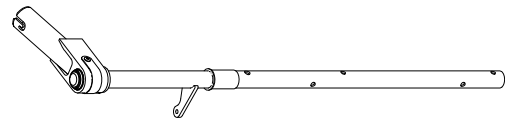

10—Connecting Bar..... (Qty 1)  
24.00”

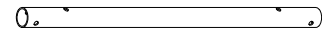

11—Front Drive Shaft..... (Qty 1)  
B Version, 11.75”

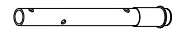

12—Removable Handle ..... (Qty 1)

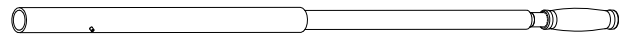

13—FBM-0062..... (Qty 1)  
PTR Suspended ErgoRack Mounting System

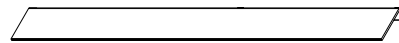

PTR Bed Rail Padding (4X)



PTR Mounting Rail (4X)



Suspension Bars (2X)



G3 Crossbar (1X)

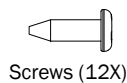

Screws (12X)



Suspension Bar End Caps (4X)



Crossbar End Caps (2X)



Crossbar Brackets (2X)



Suspension Bar Brackets (6X)

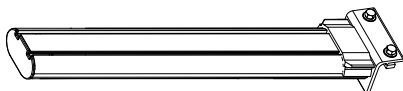

PTR Rack Leg, Front, 23” (2X)

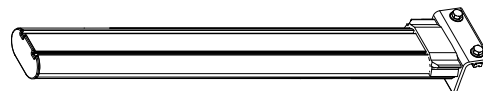

PTR Rack Leg Rear, 28.50” (2X)



PTR Tube Foot Clamp (8X)

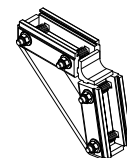

PTR Crossbar/Leg Connector (4X)

14—HKT-8163-Rotation Hardware Kit ..... (Qty 2)  
(Not called out in Overview)

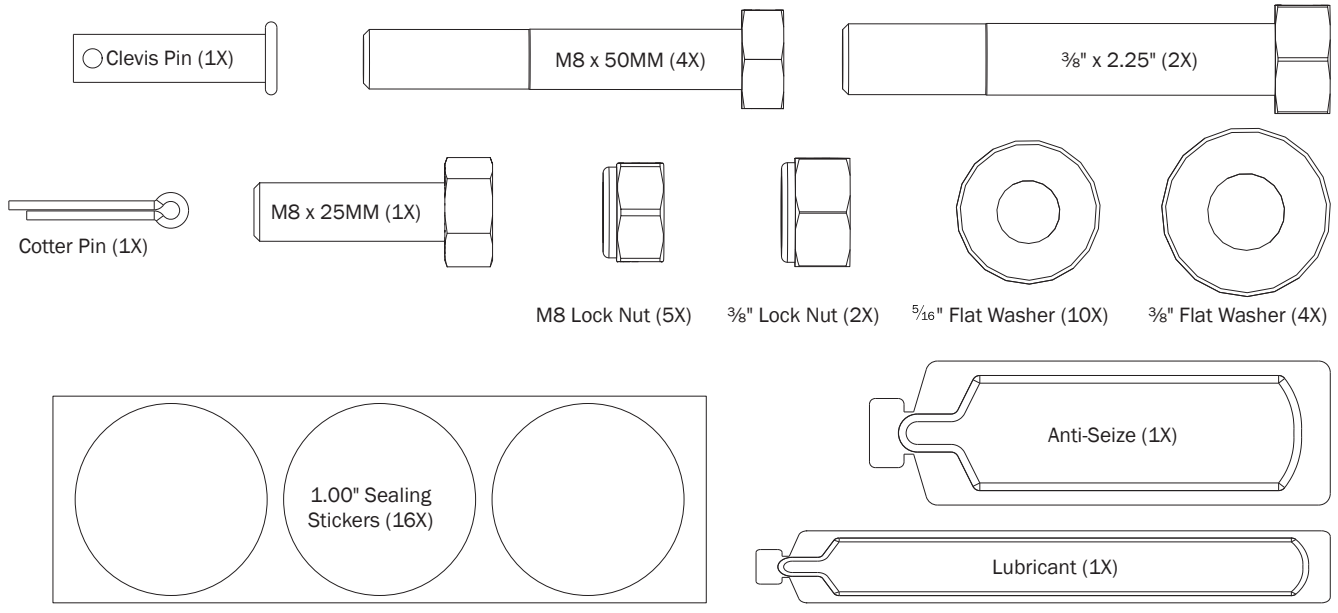

# FBM-0062 ASSEMBLY SEQUENCE

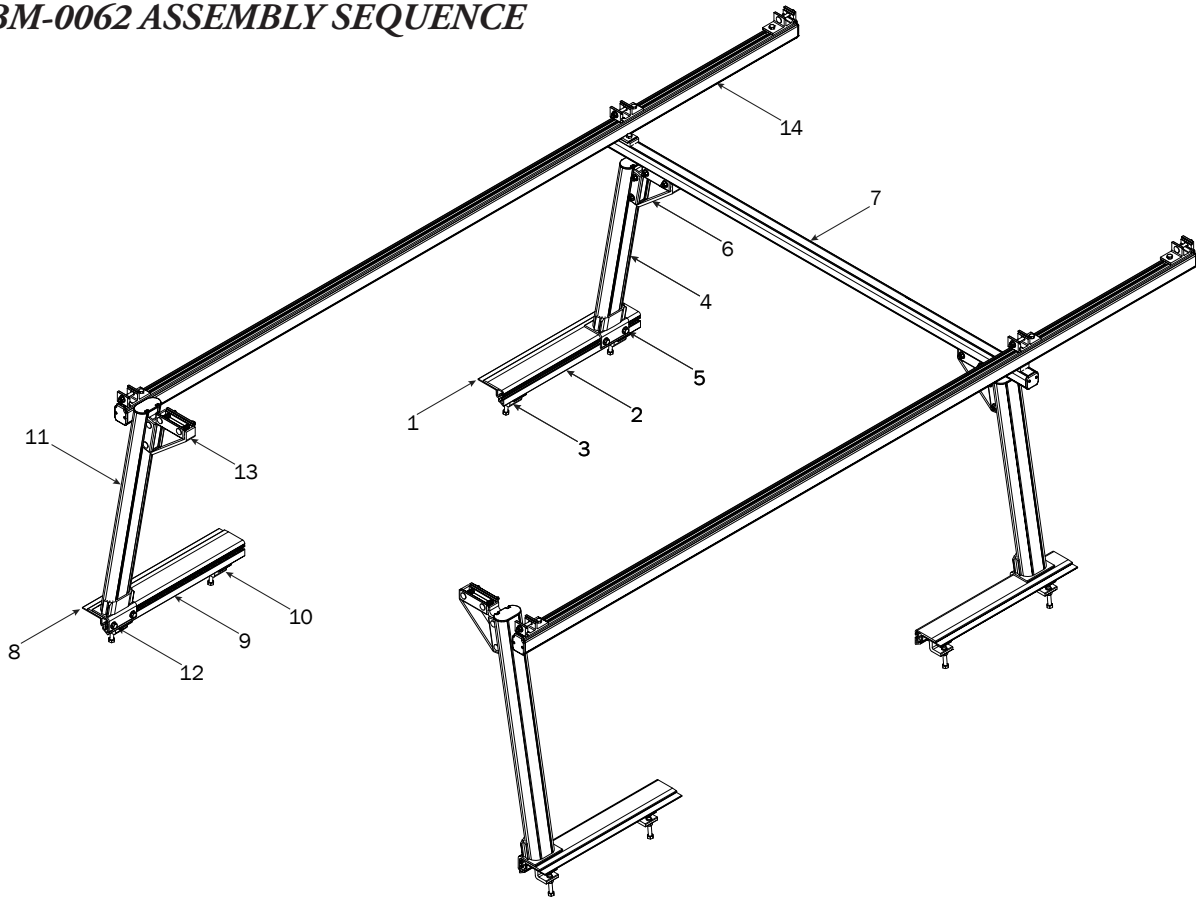

**1** Place the PTR Foot Pad onto the truck's bed rail.

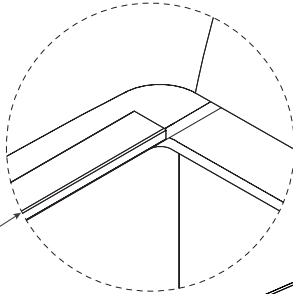

**2** Place the PTR Tube Foot on top of the bed rail Foot Pad.

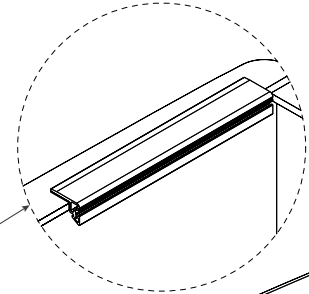

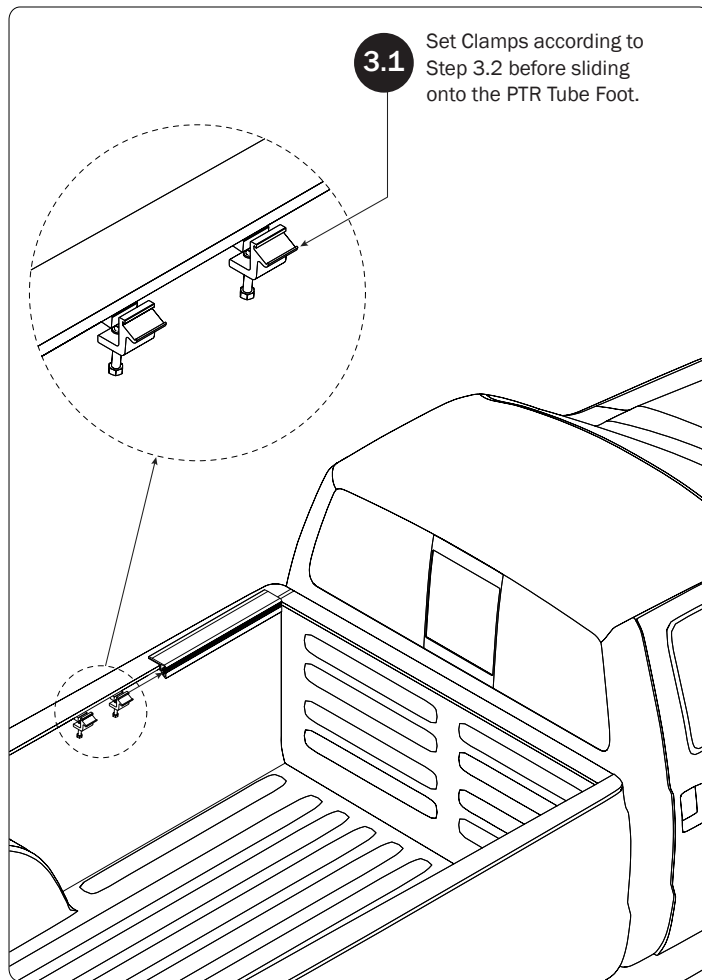

For most applications, the thick side of the Truck Clamp Pad should face inward toward the Tube Foot Clamp as shown in Figure C.

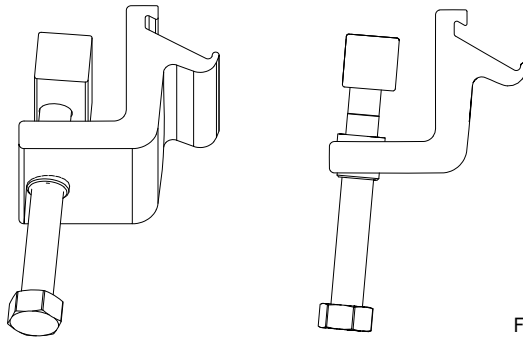

Figure C

Position the Truck Clamp Pad to Figure D if extra clearance is required for a properly seated installation.

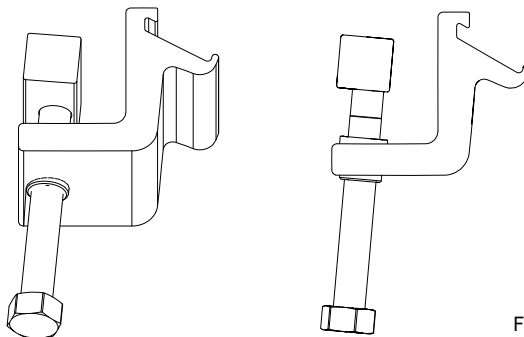
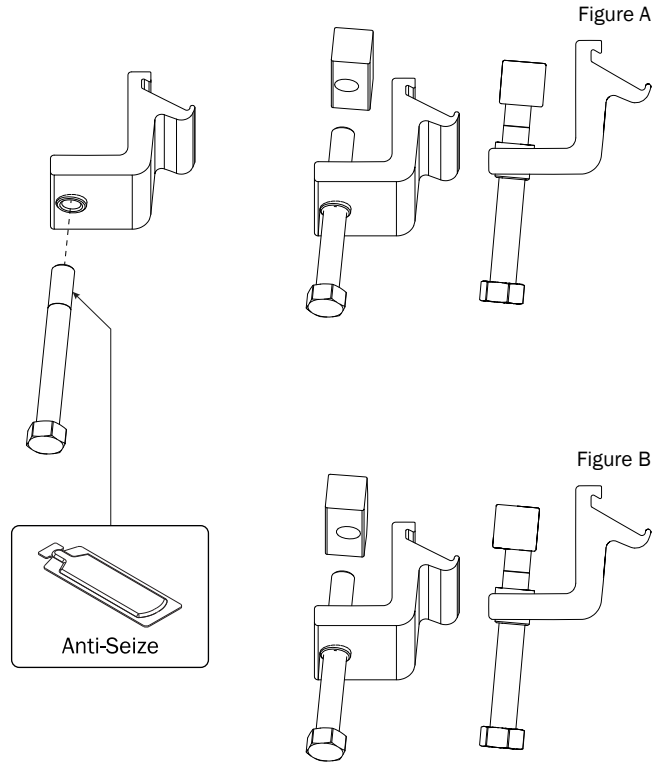
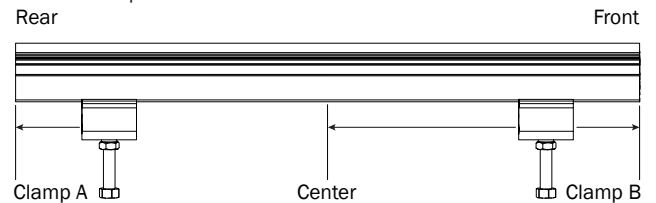

Figure D

**3.2** Place Truck Clamp Pad on threaded end of the Tube Foot Clamp Bolt. The Truck Clamp Pad has an offset hole. Set Clamp Pad according to Figures A or B.



**3.3** Whenever possible, it's preferred to place the Clamps on the thickest metal sections of the bed rail. Place Clamp A as far rearward as possible while still on double wall. Place Clamp B as far forward as possible while still on double wall. Torque Clamp Bolts to 120 in-lbs.



**Note:** Do not position Clamp B rearward of the center of the Tube Foot.

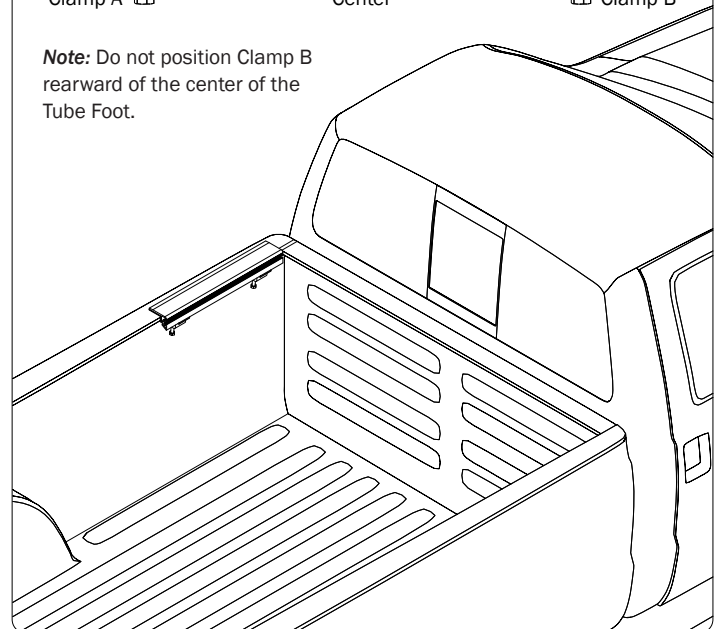

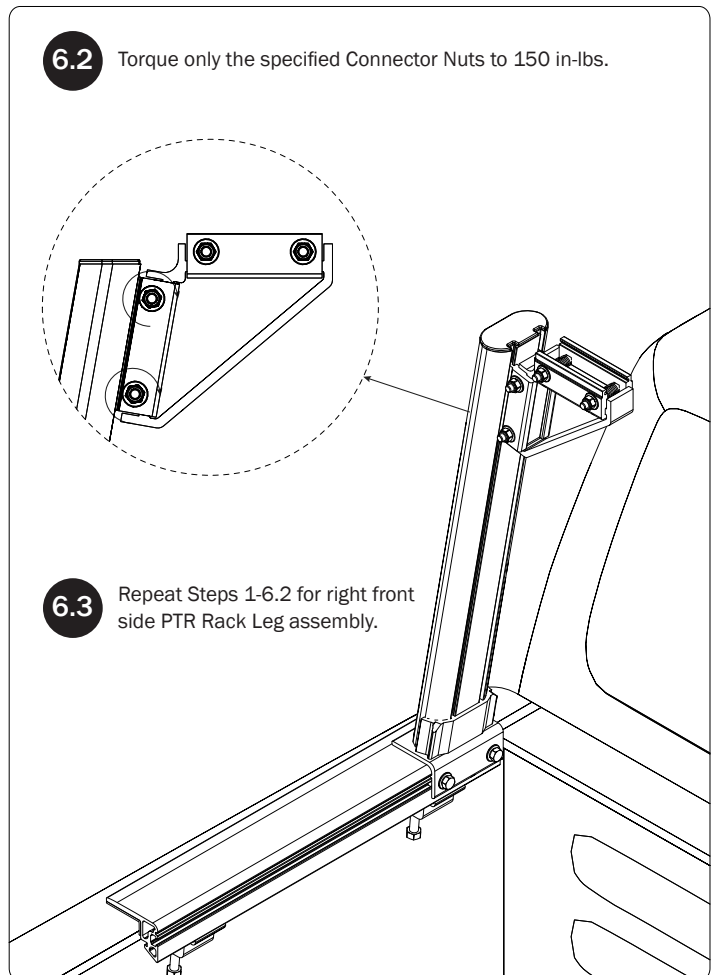
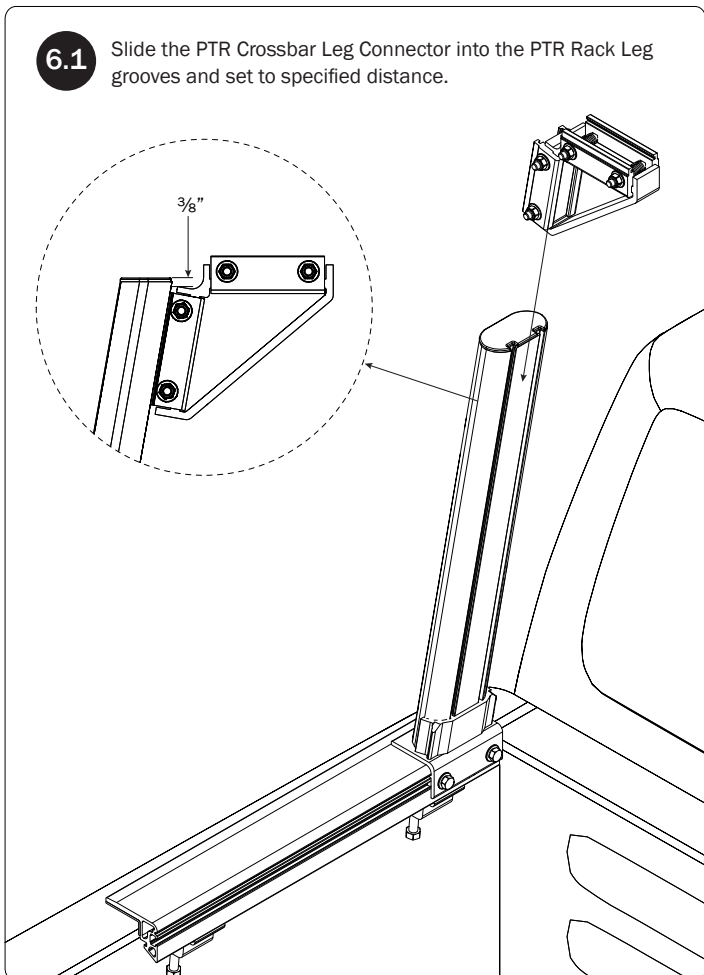
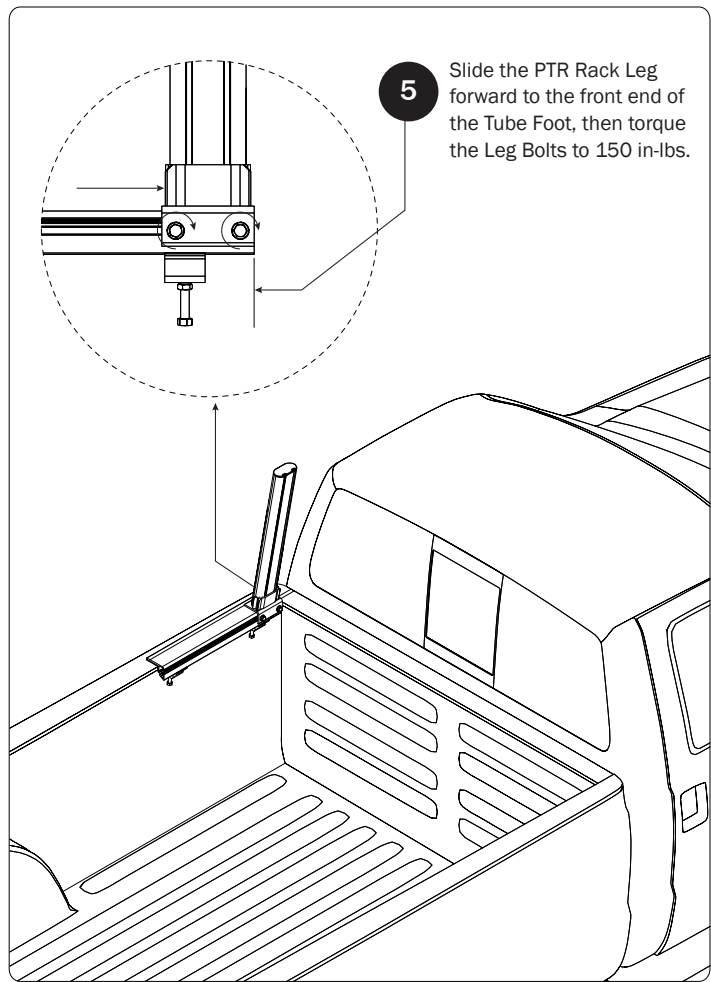
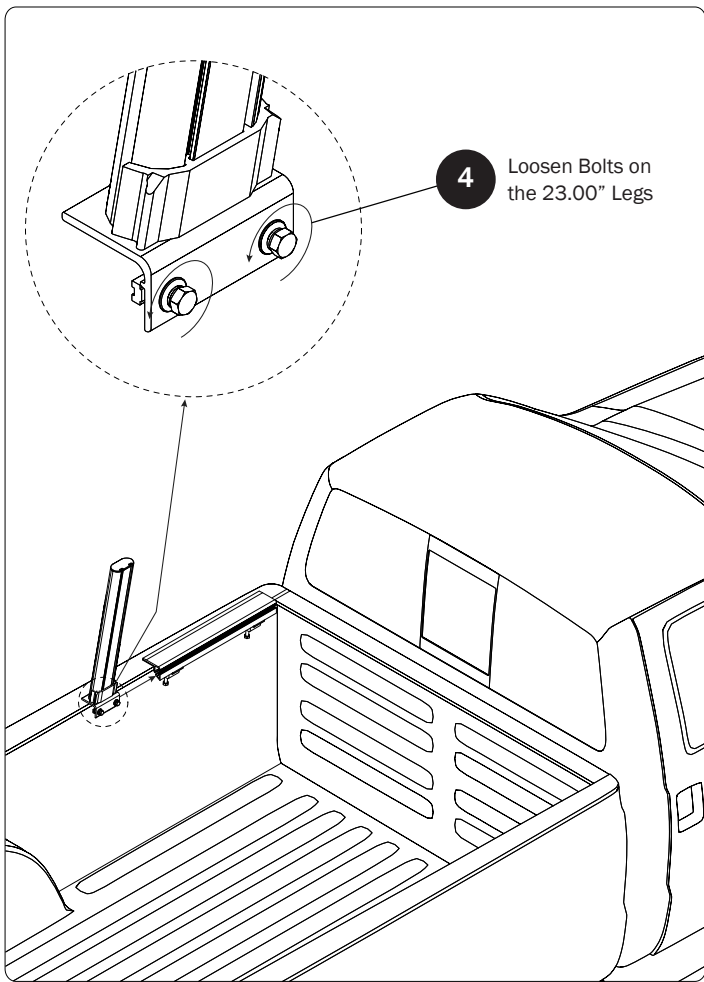

**6.3** Repeat Steps 1-6.2 for right front side PTR Rack Leg assembly.

**7.1** Place the Crossbar onto the PTR Rack Leg Connectors.

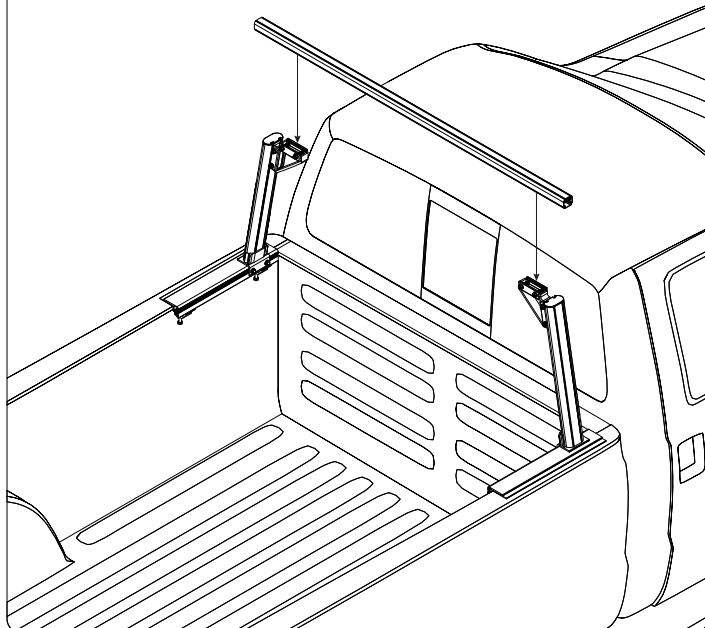

**7.2** Center the Crossbar onto the PTR Rack Legs as shown.

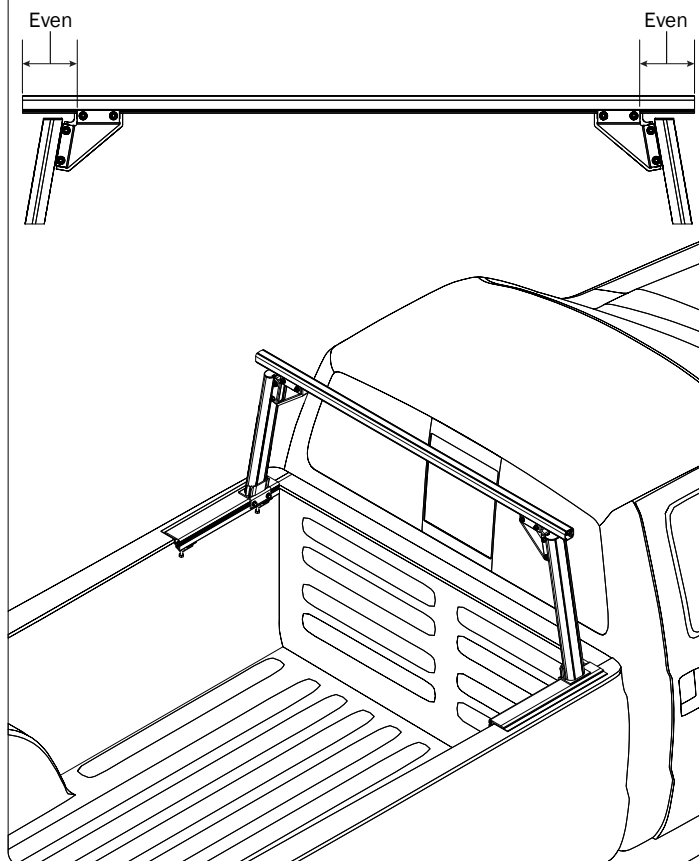

**7.3** Torque nuts to 150 in-lbs.

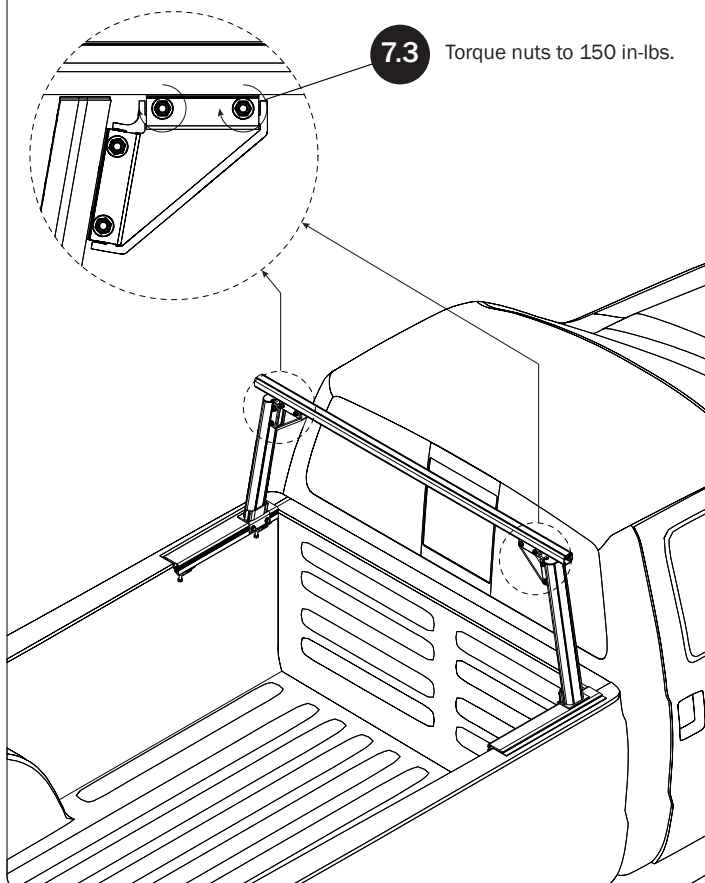

**7.4** Position the Crossbar Brackets onto Crossbar and position as shown. Do not tighten Brackets until Step 16.6. Install the Crossbar End Caps using the supplied screws.

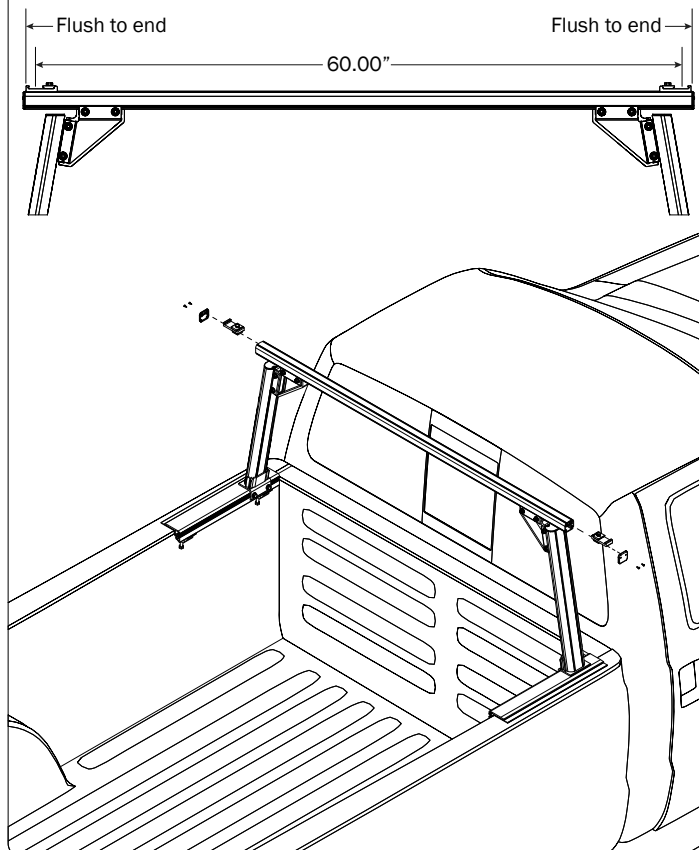



8 Place the Foot Pad onto the truck's bed rail.

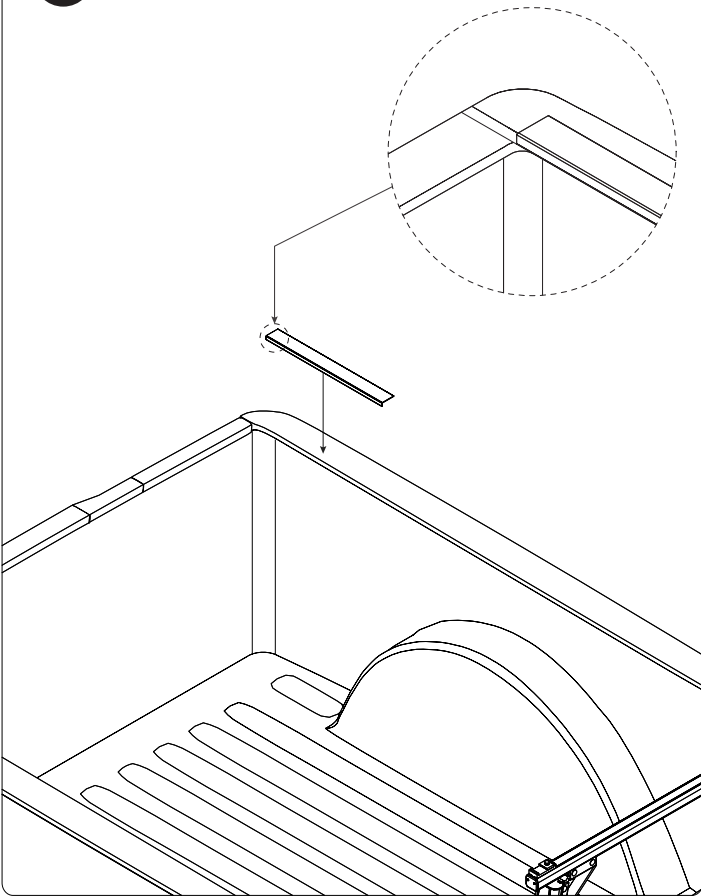

9 Place the PTR Tube Foot on top of the bed rail Foot Pad.

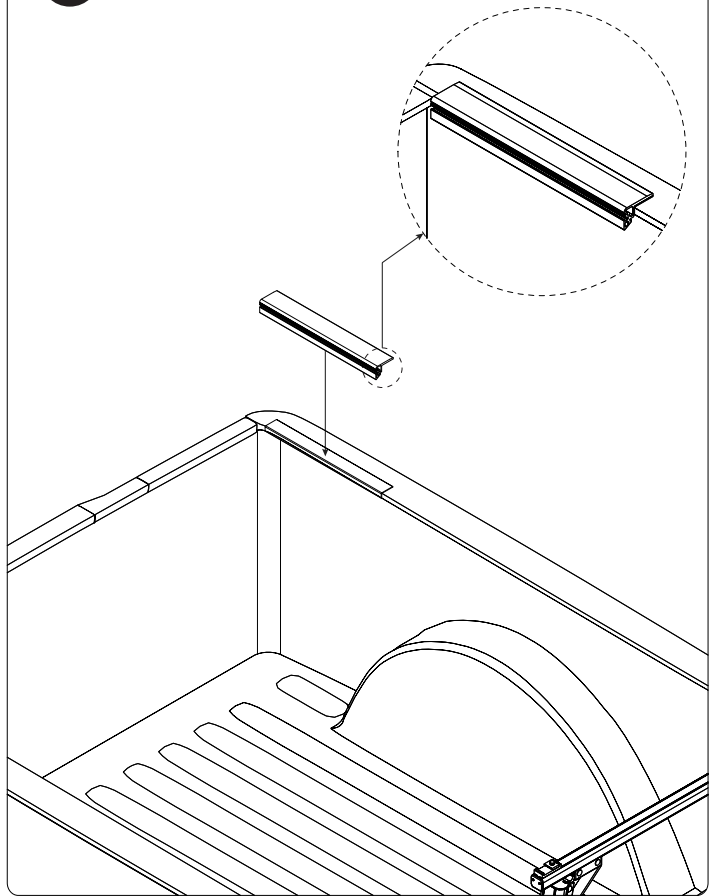

10.1

Set Clamps according to Step 10.2 before sliding onto PTR Tube Foot.

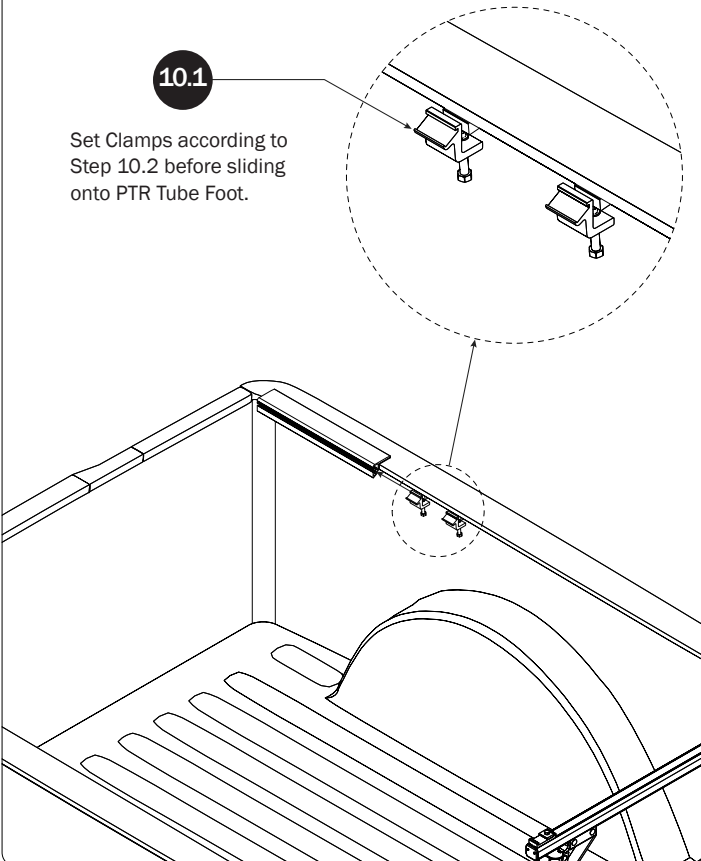

10.2

Place Truck Clamp Pad on threaded end of the Tube Foot Clamp Bolt. The Truck Clamp Pad has an offset hole. Set Clamp Pad according to Figures E or F.

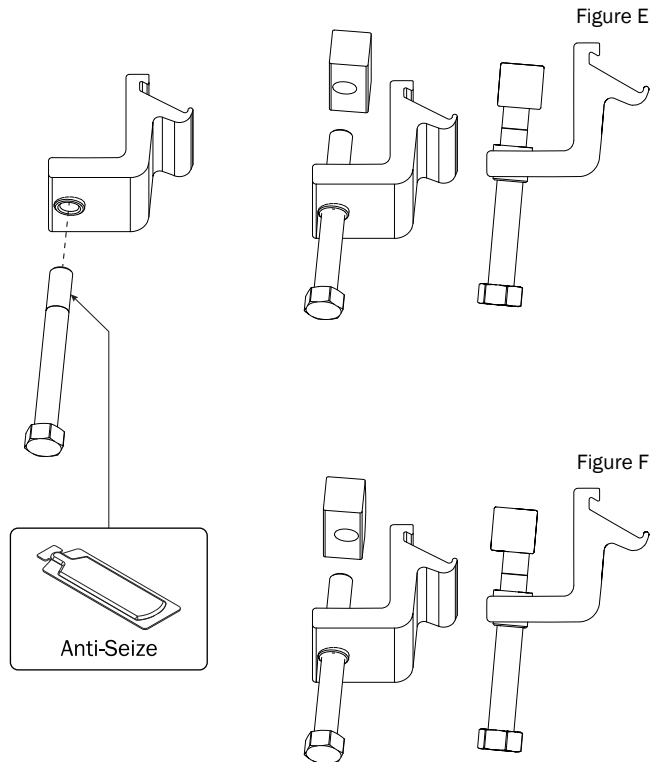

For most applications, the thick side of the Truck Clamp Pad should face inward toward the Tube Foot Clamp as shown in Figure E.

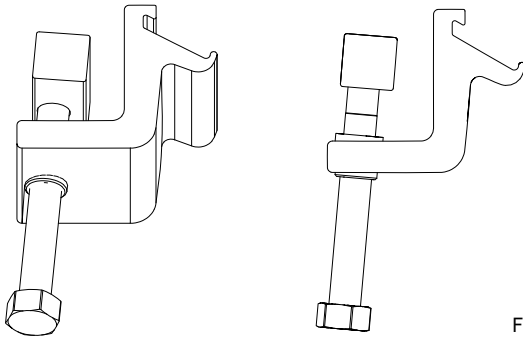

Figure E

Position the Truck Clamp Pad to Figure F if extra clearance is required for a properly seated installation.

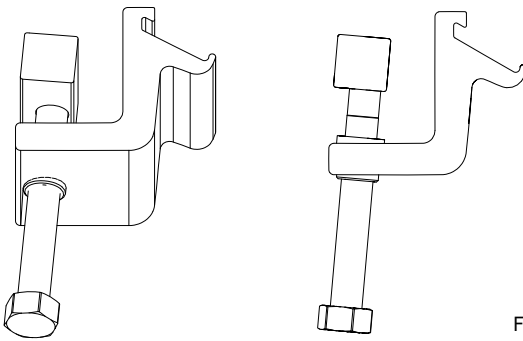
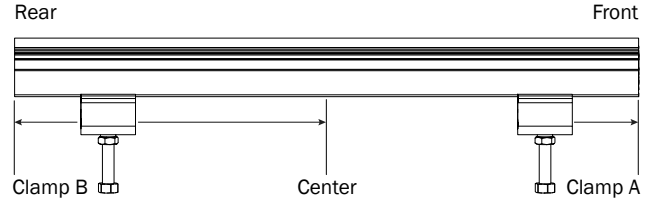

Figure F

10.3

Whenever possible, it's preferred to place the Clamps on the thickest metal sections of the bed rail. Place Clamp A as far forward as possible while still on double wall. Place Clamp B as far rearward as possible while still on double wall. Torque Clamp Bolts to 120 in-lbs.



**Note:** Do not position Clamp B rearward of the center of the Mounting Foot.

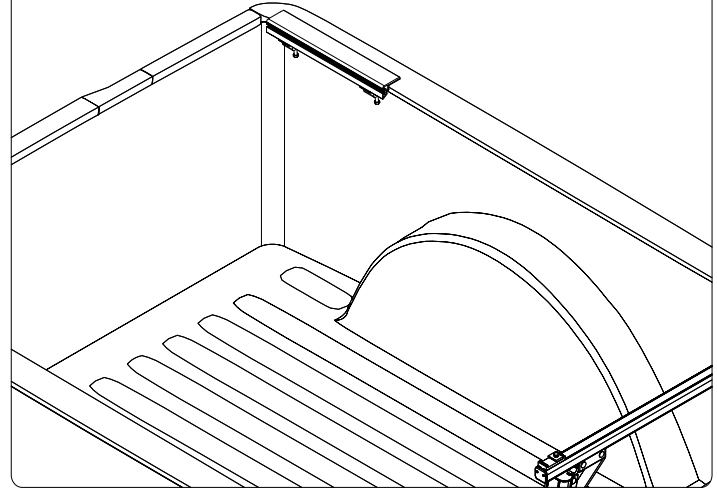

11

Loosen Bolts on the 28.50" Legs

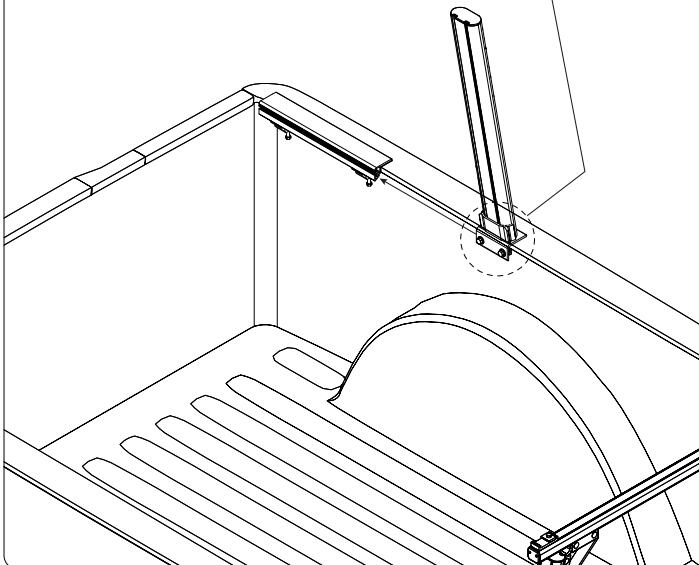
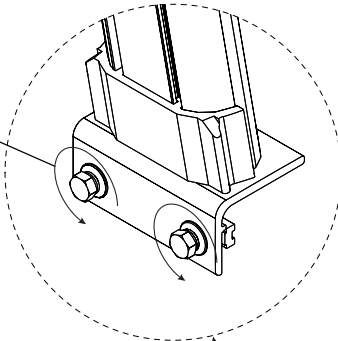

12

Slide the PTR Rack Leg rearward to the back end of the Tube Foot, then torque the Rack Leg Bolts to 150 in-lbs.

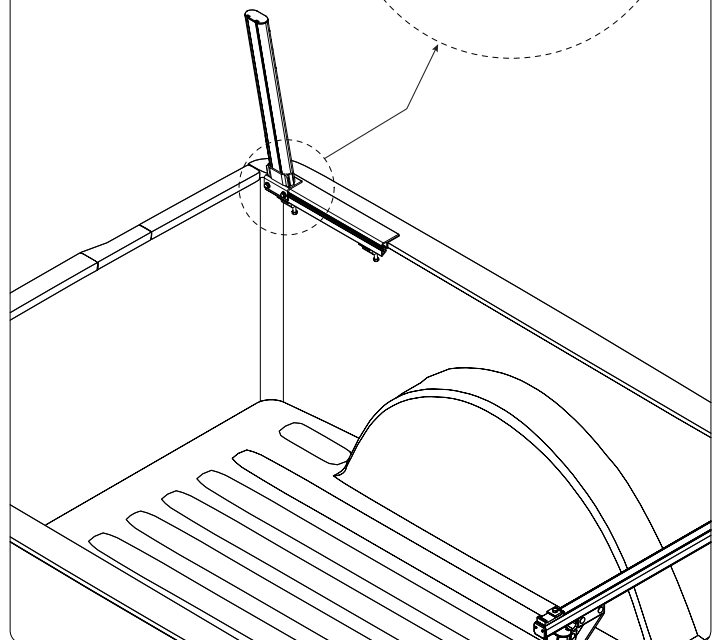
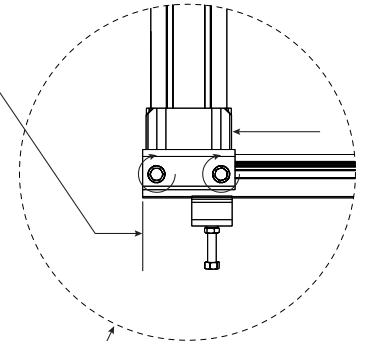

**13.1** Slide the PTR Crossbar Leg Connector into the PTR Rack Leg grooves and set to specified distance.

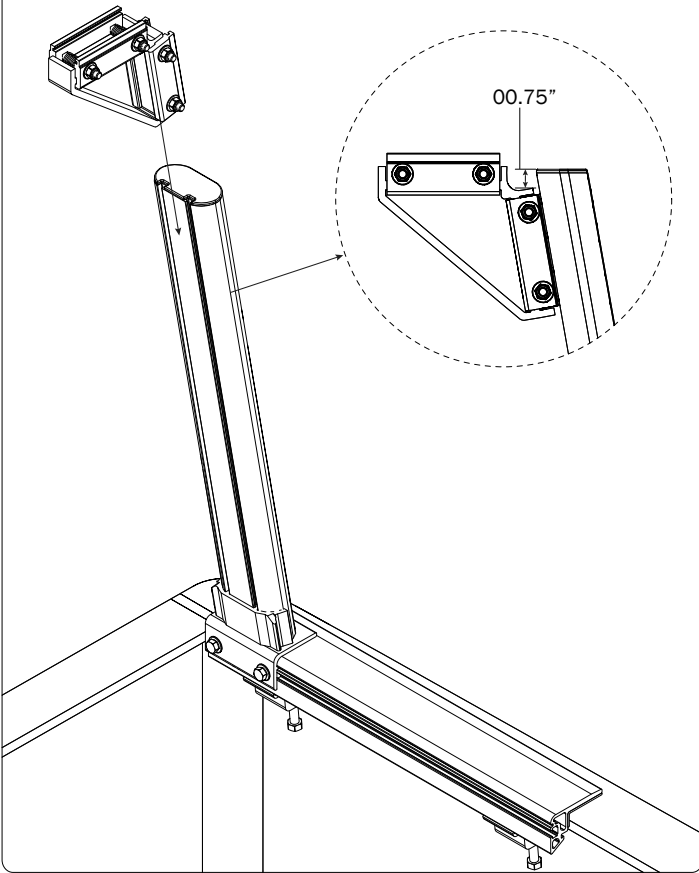

**13.2** Torque only the specified Connector nuts to 150 in-lbs.

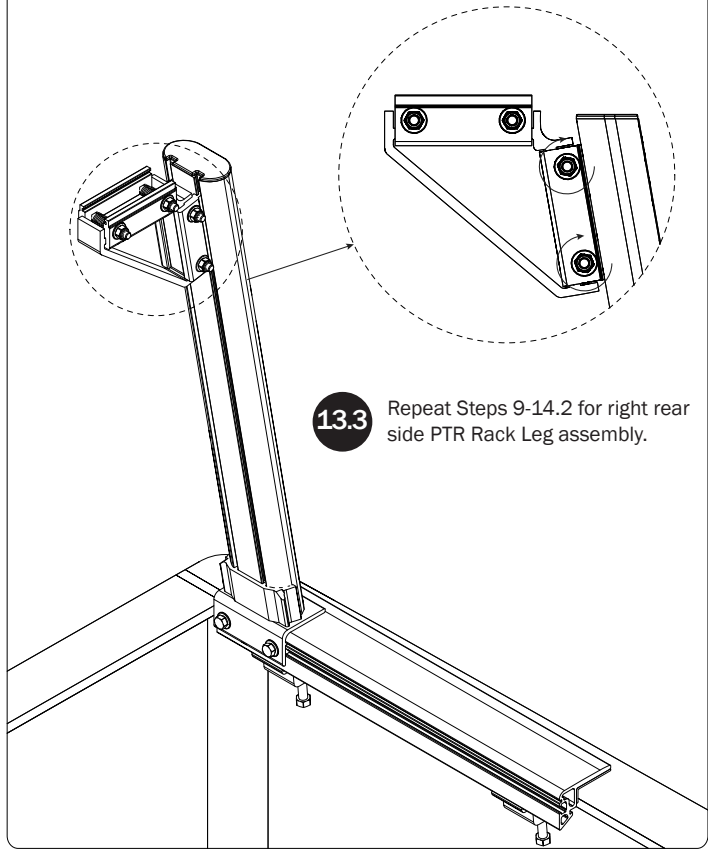

**13.3** Repeat Steps 9-14.2 for right rear side PTR Rack Leg assembly.

**14.1** Loosen the 30MM Hex Head Bolt to allow the Aluminum Strip Nut into the Suspension Bar's upper groove. Loosen the clamp nuts for Crossbar installation on Steps 16.1-18.4.

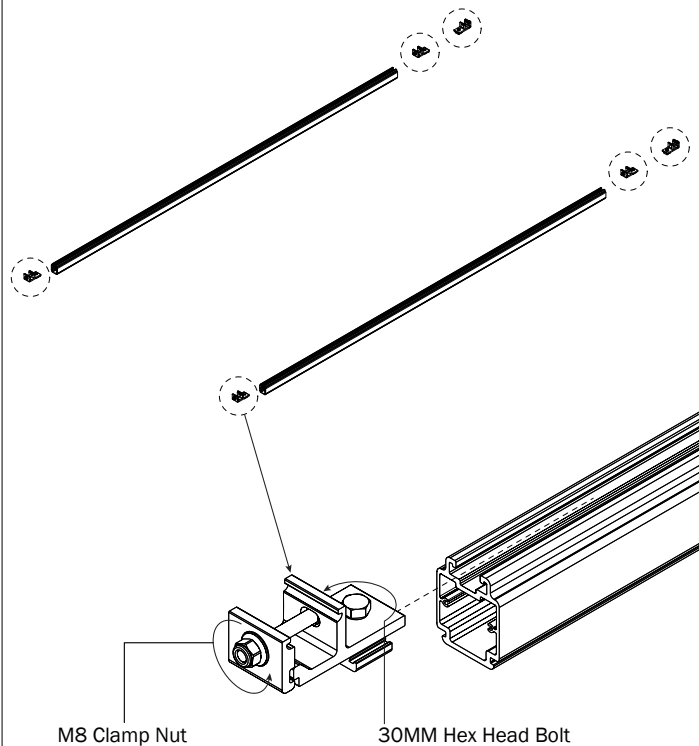

**14.2** Attach the Suspension Bar End Caps using supplied screws.

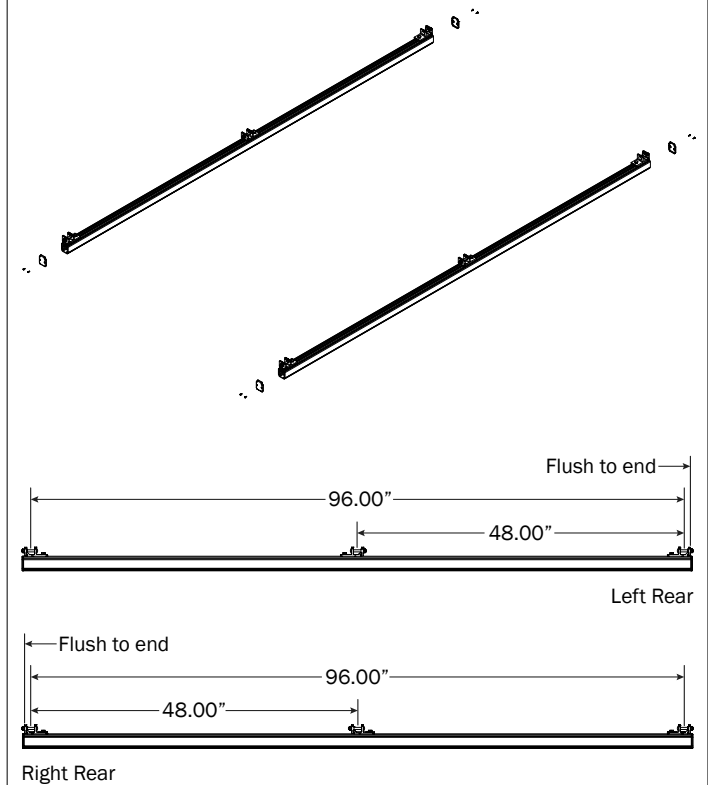

**RIGHT ROTATION  
ASSEMBLY SEQUENCE**

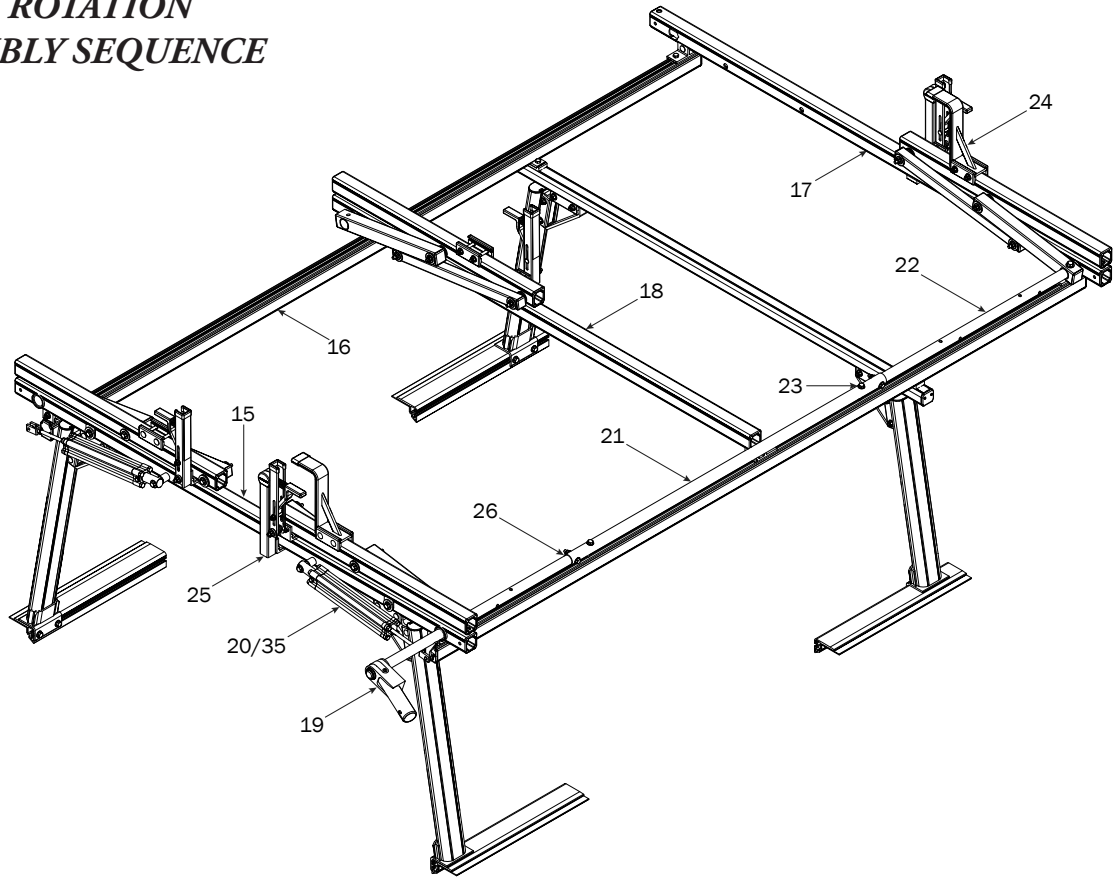

**REAR CROSSBAR**

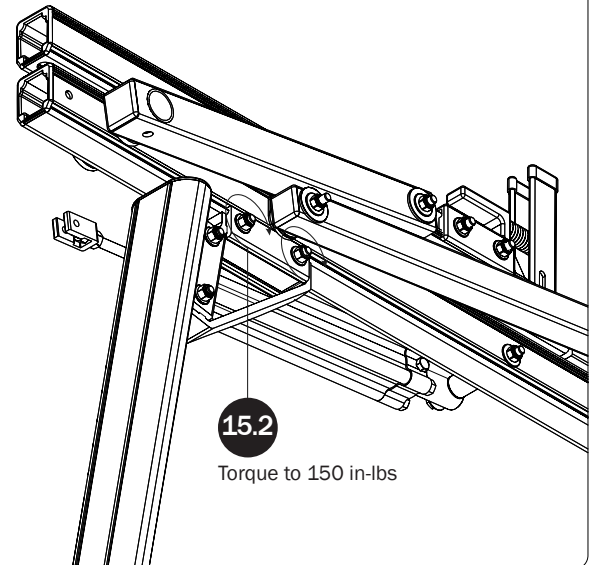
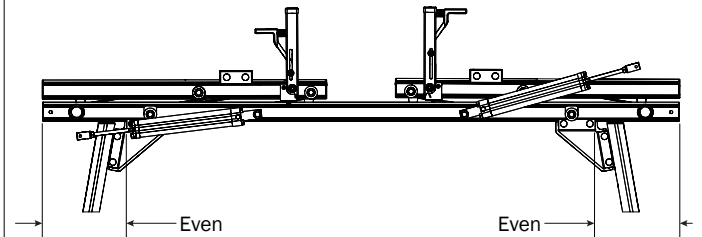
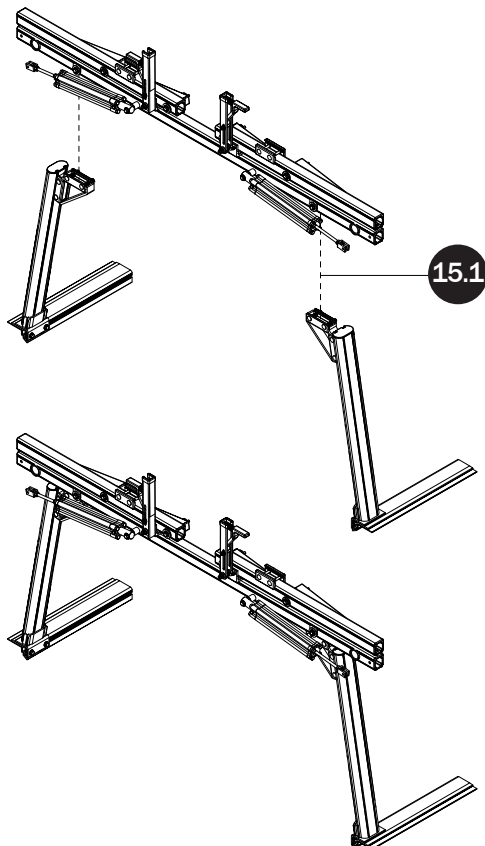

## SUSPENSION BARS

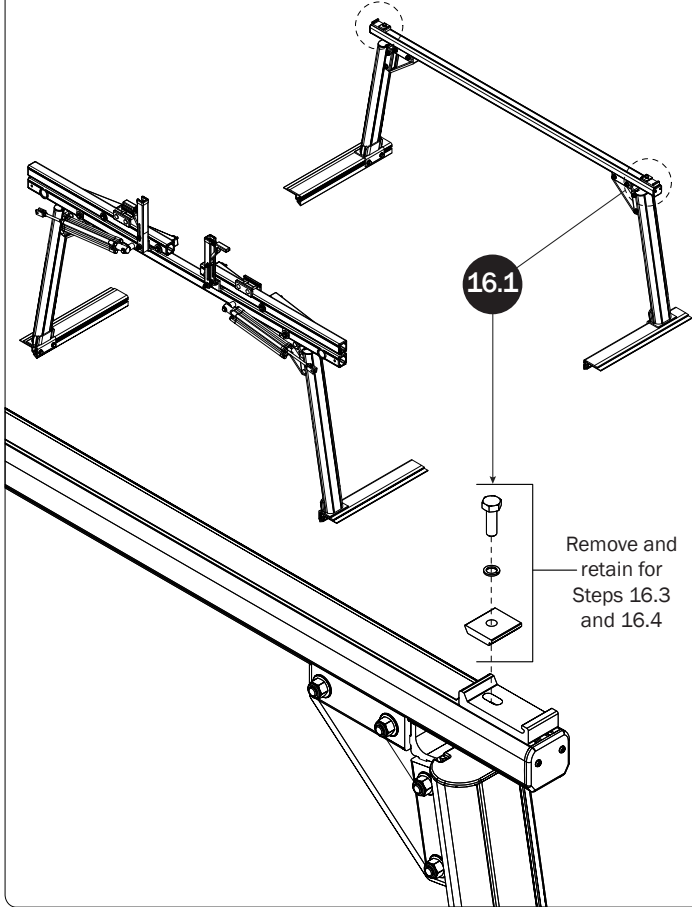

16.2

Place the Suspension Bars on the Front Crossbar Clamps as shown in Figure H, then attach the rear Suspension Bar Clamps to the bottom of the Rear Crossbar as shown in Figure G.

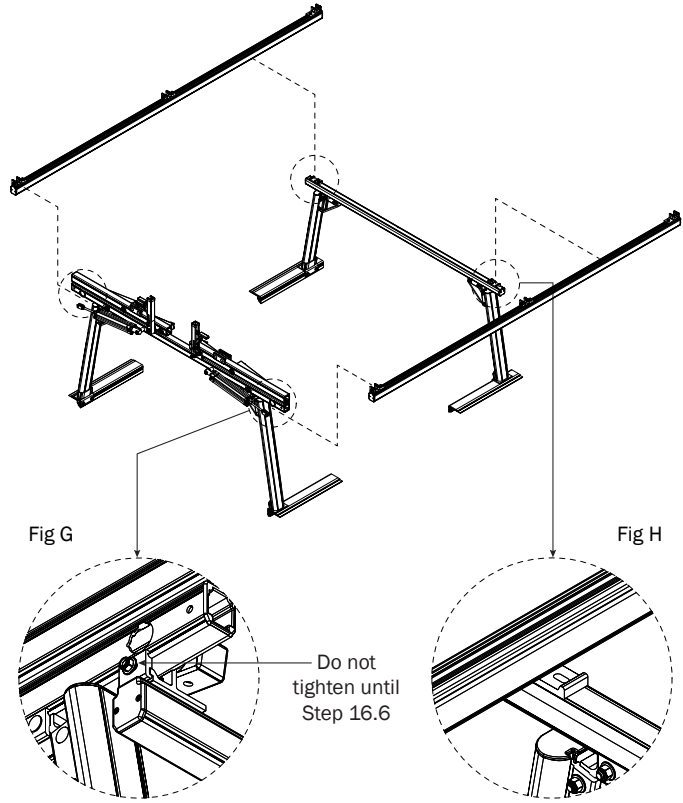

16.3

Slide the Bracket Clamp into the Crossbar groove and slide onto the Crossbar Mounting Bracket aligning the bolt holes.

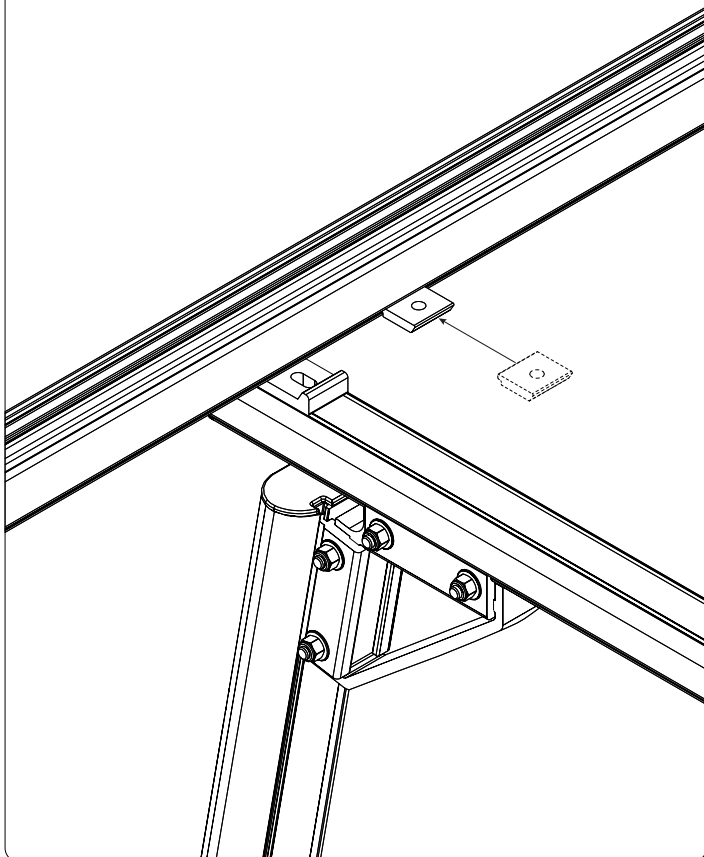

16.4

Install the Crossbar Mounting Bracket hardware, but do not tighten until Step 16.6.

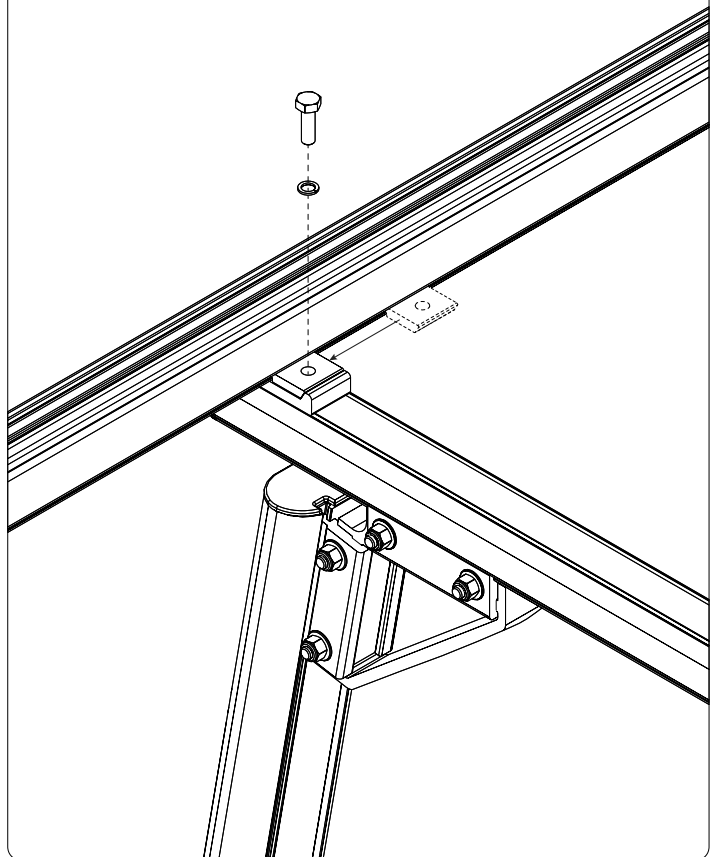

16.5 Adjust Suspension Bars according to Figure I

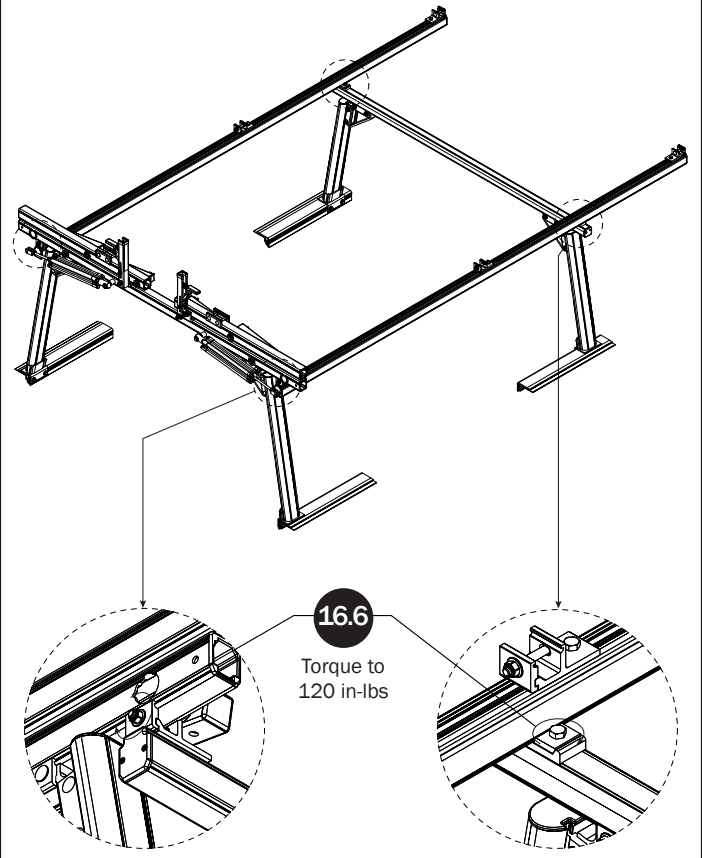
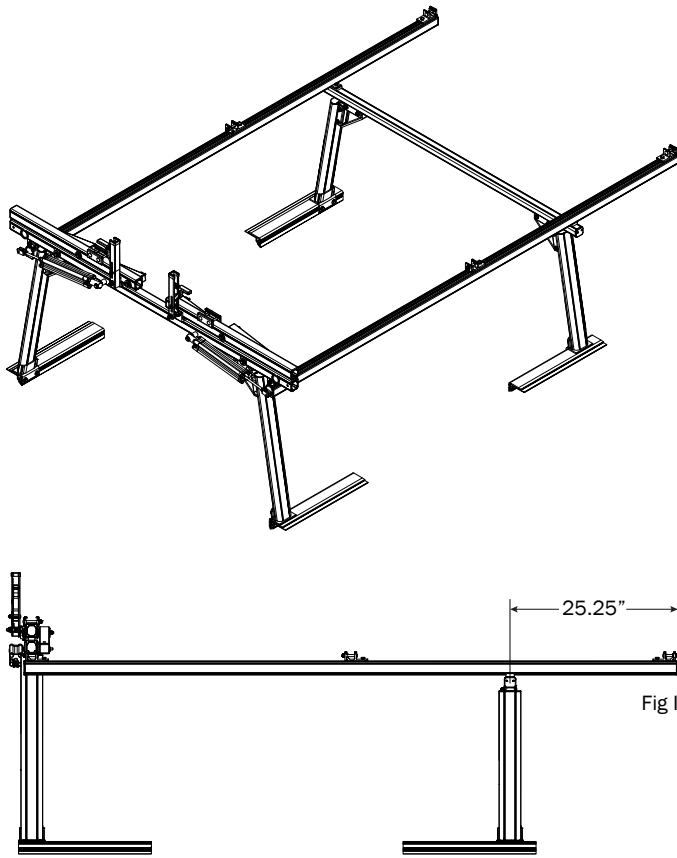

FRONT CROSSBAR

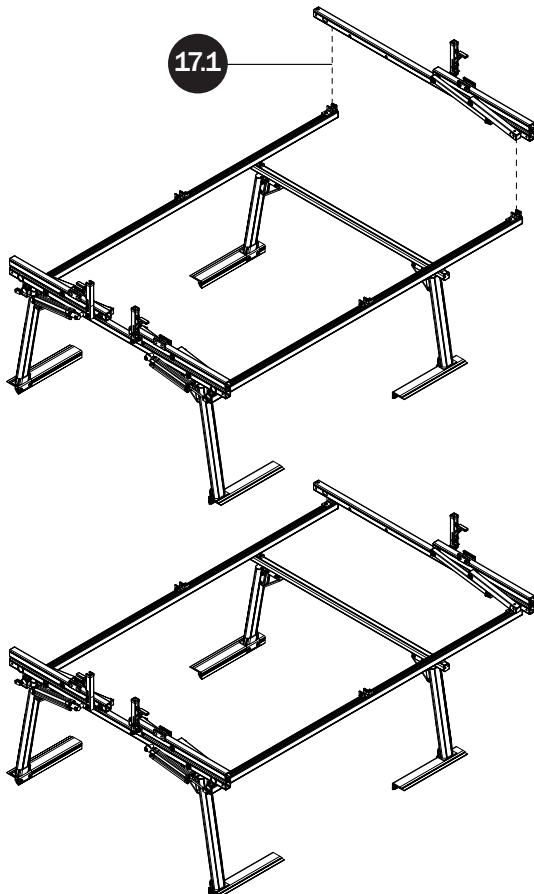

17.2 Adjust Front Crossbar on Suspension Channels as shown.

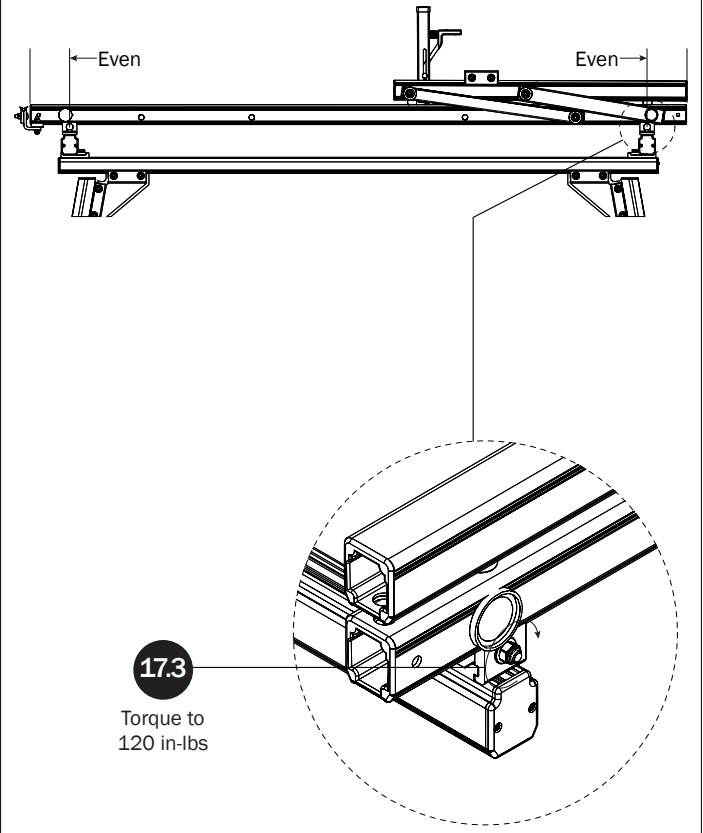

## CENTER CROSSBAR

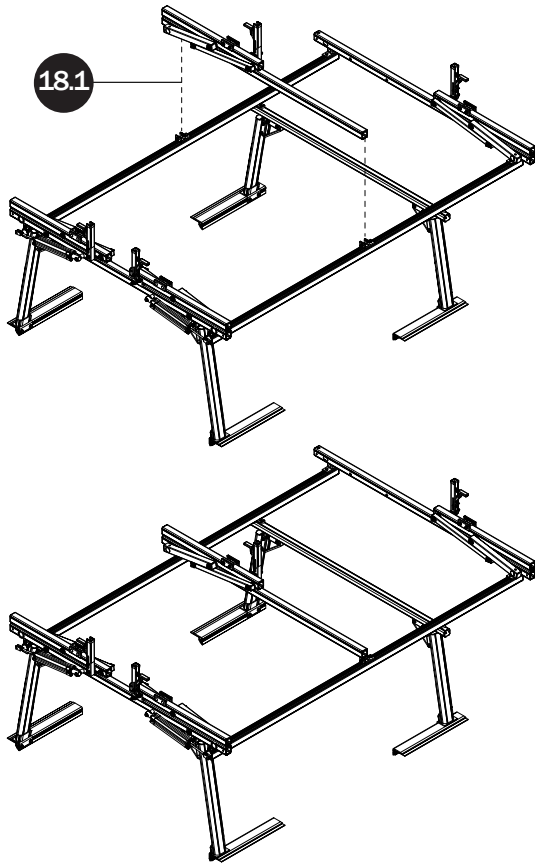

18.1

18.2 Adjust Center Crossbar according to Figure J

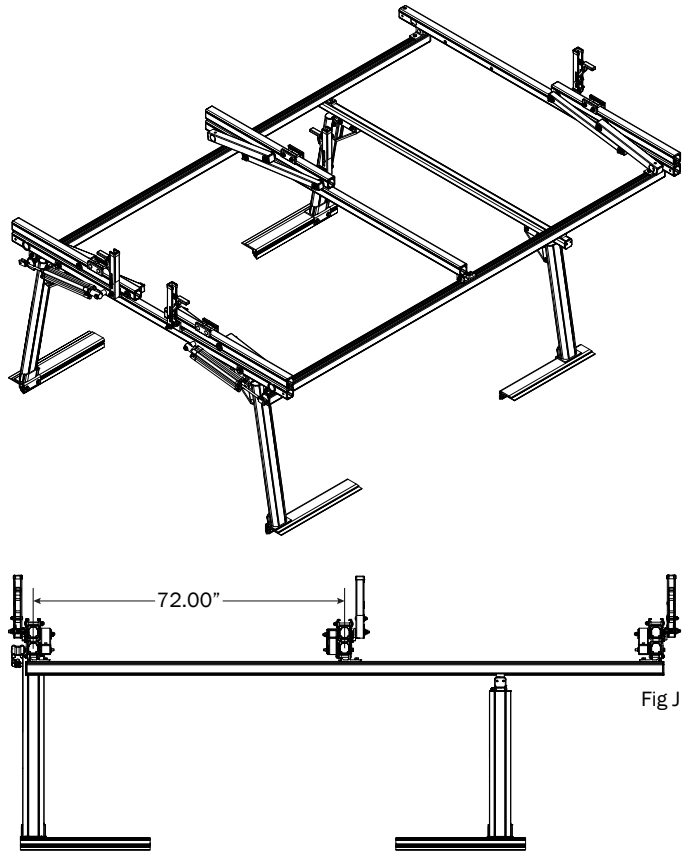

72.00"

Fig J

18.3 Adjust Front Crossbar on Suspension Channels as shown.

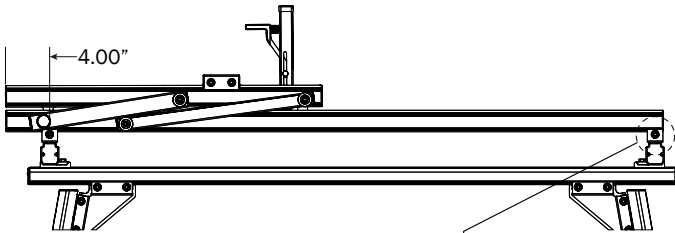

4.00"

18.4

Torque to 120 in-lbs

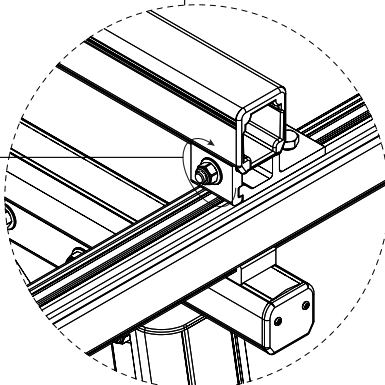

## REAR DRIVE SHAFT

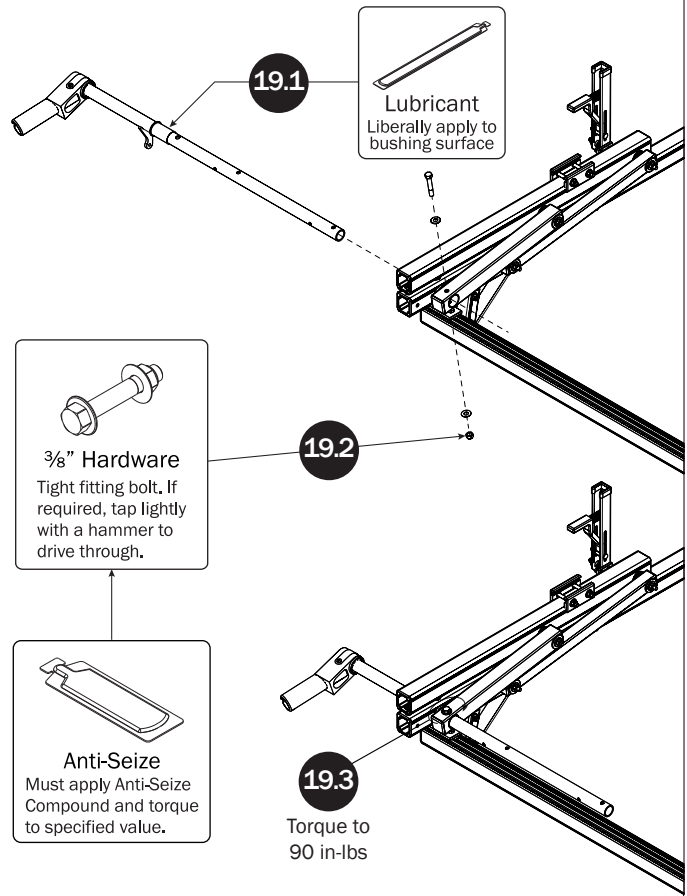

19.1

Lubricant  
Liberally apply to  
bushing surface

19.2

$\frac{3}{8}$ " Hardware  
Tight fitting bolt. If  
required, tap lightly  
with a hammer to  
drive through.

19.3

Torque to  
90 in-lbs

**CYLINDER HARDWARE**

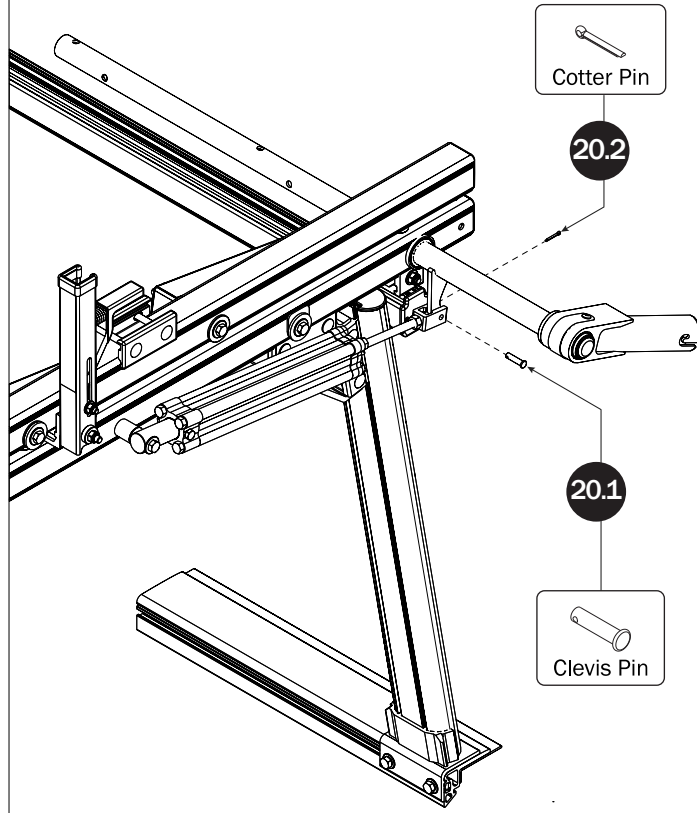

**CONNECTING BAR**

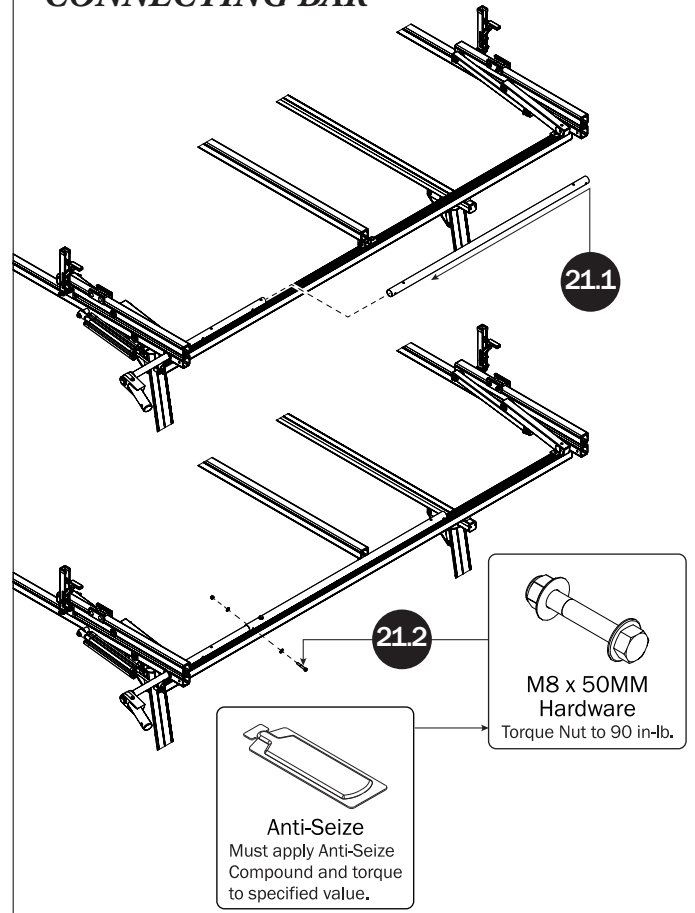

**FRONT DRIVE SHAFT**

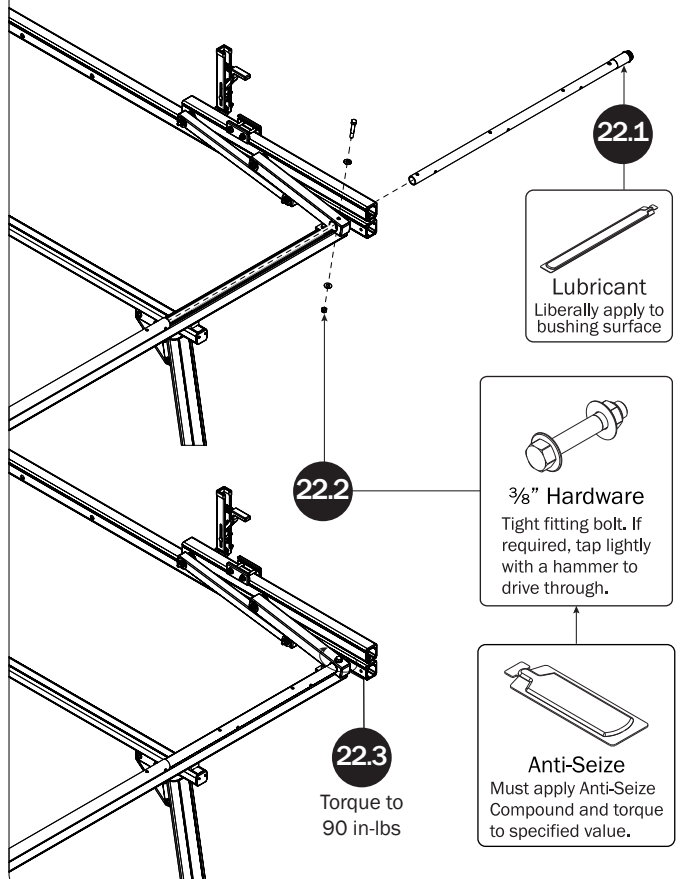

**CONNECTING BAR FASTENERS**

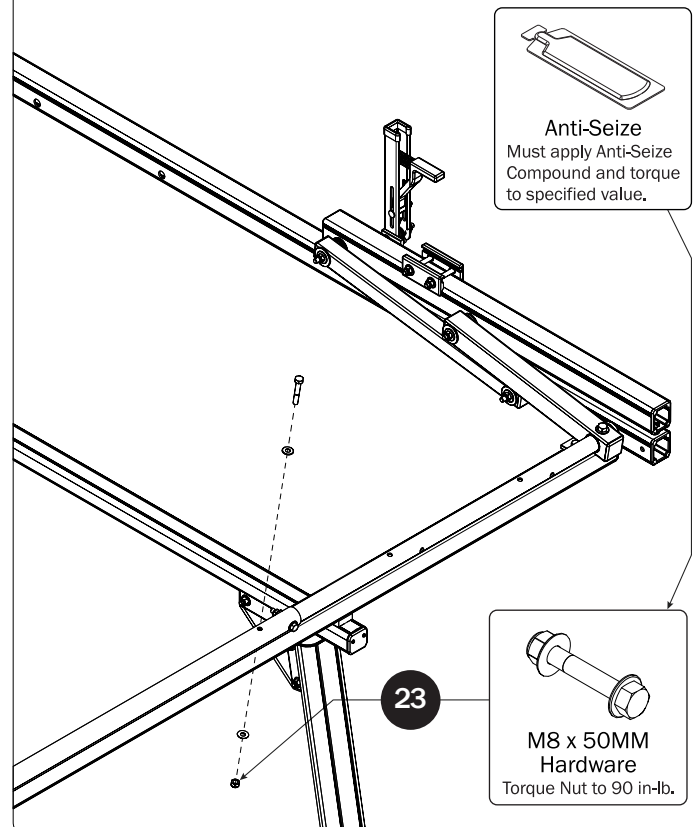



### Z POSTS

SEE QUICK START GUIDE FOR ADJUSTMENTS

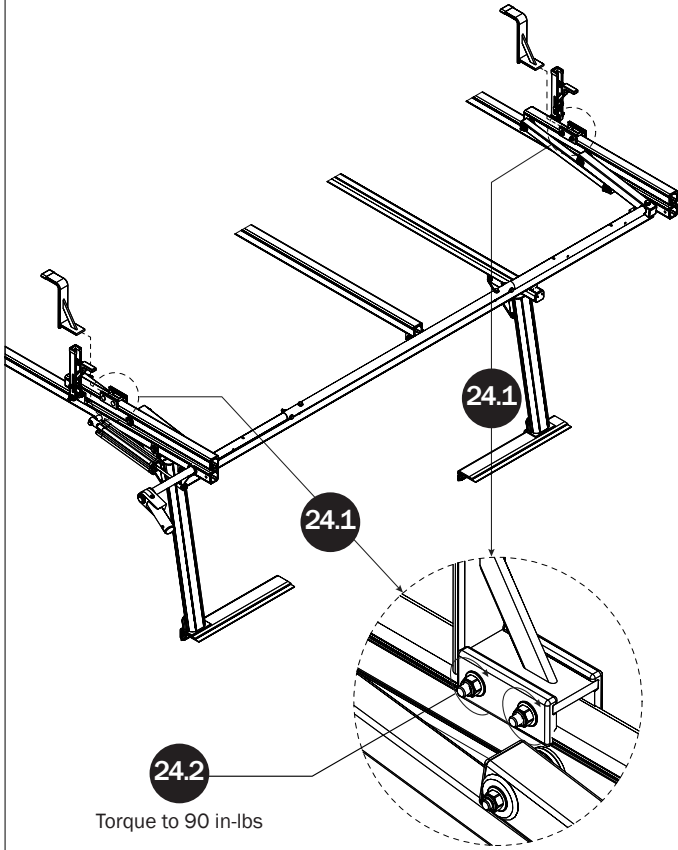

### L POSTS

SEE QUICK START GUIDE FOR ADJUSTMENTS

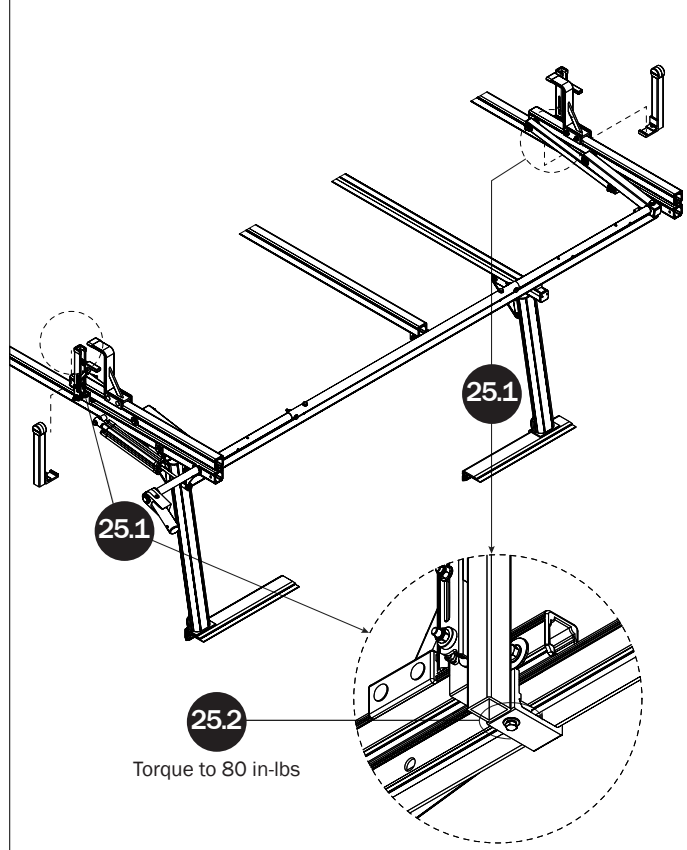

### DRIVE SHAFT SEALING

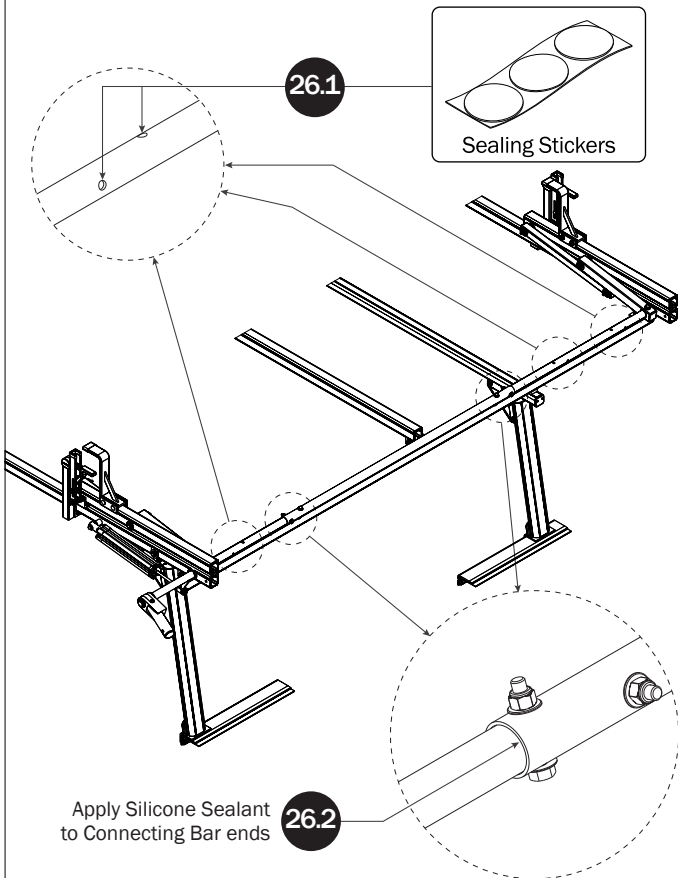

**LEFT ROTATION ASSEMBLY SEQUENCE**

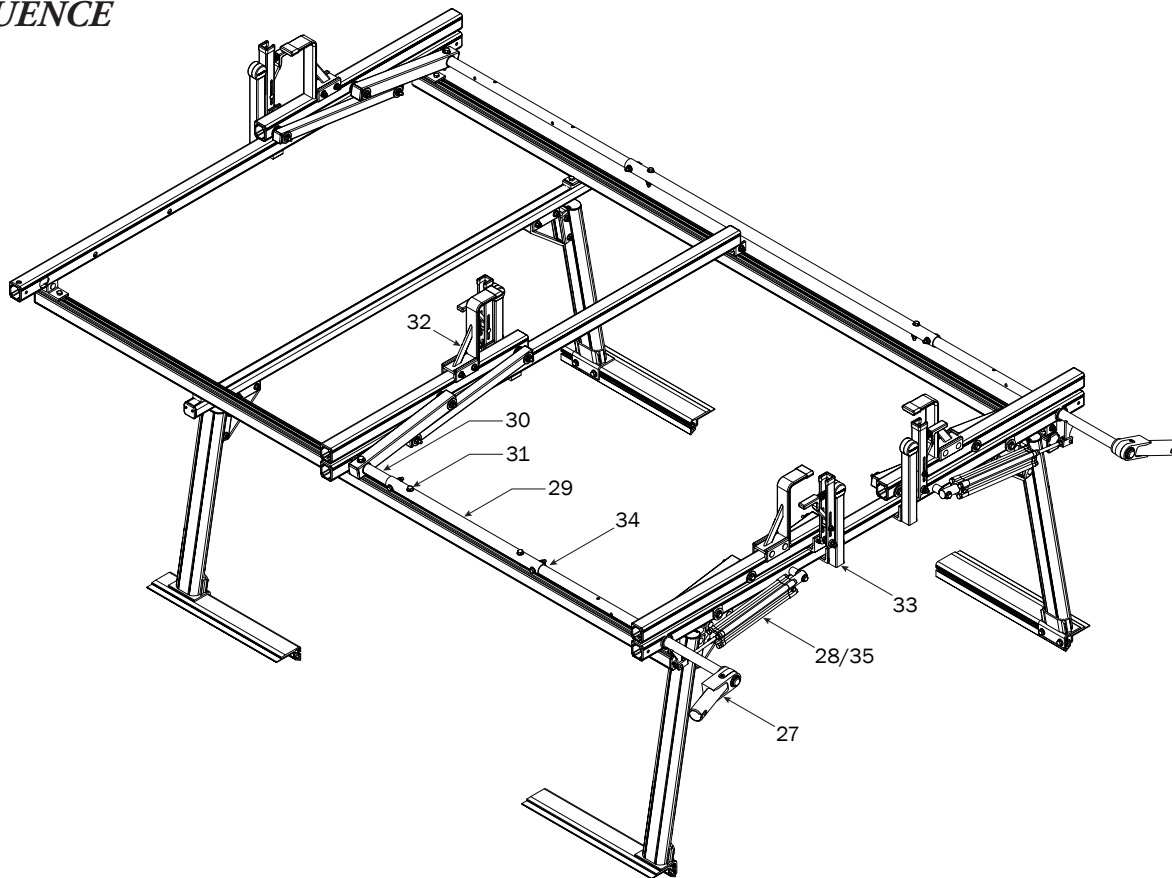

**PRR3-0021 RACK ASSEMBLY—LEFT SIDE ROTATION**

**REAR DRIVE SHAFT**

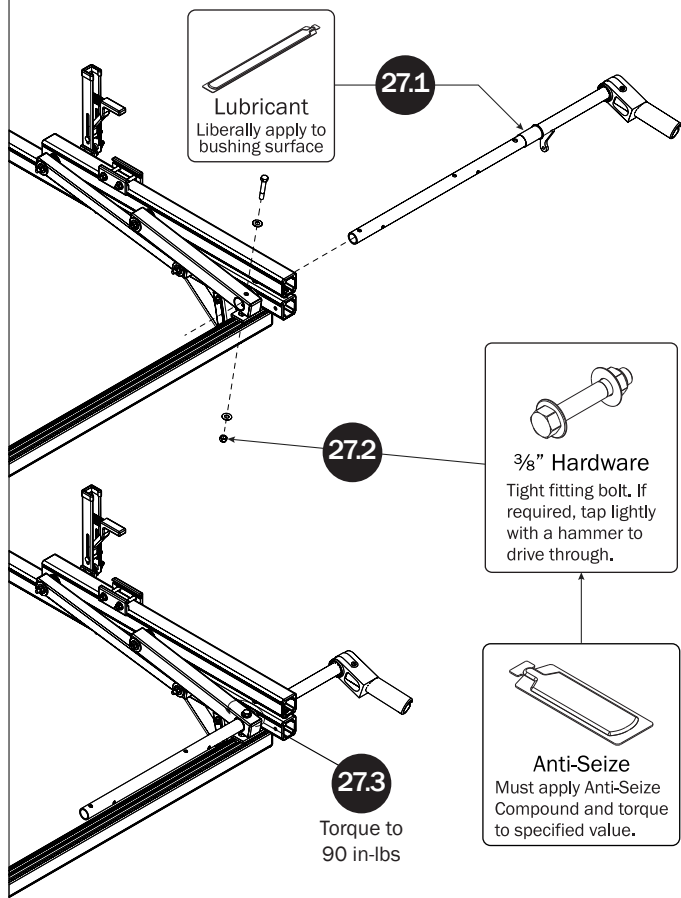

**CYLINDER HARDWARE**

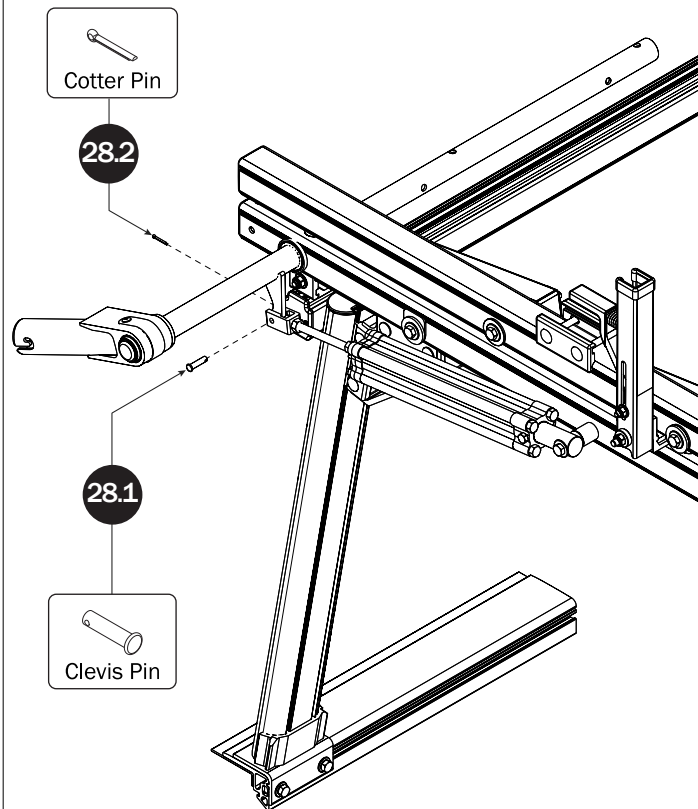

**CONNECTING BAR**

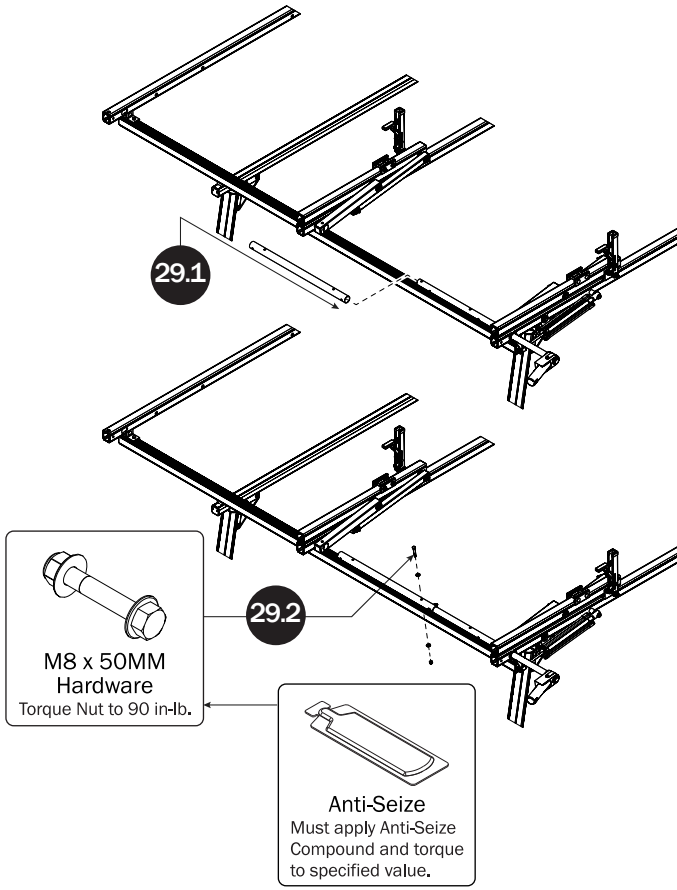

**FRONT DRIVE SHAFT**

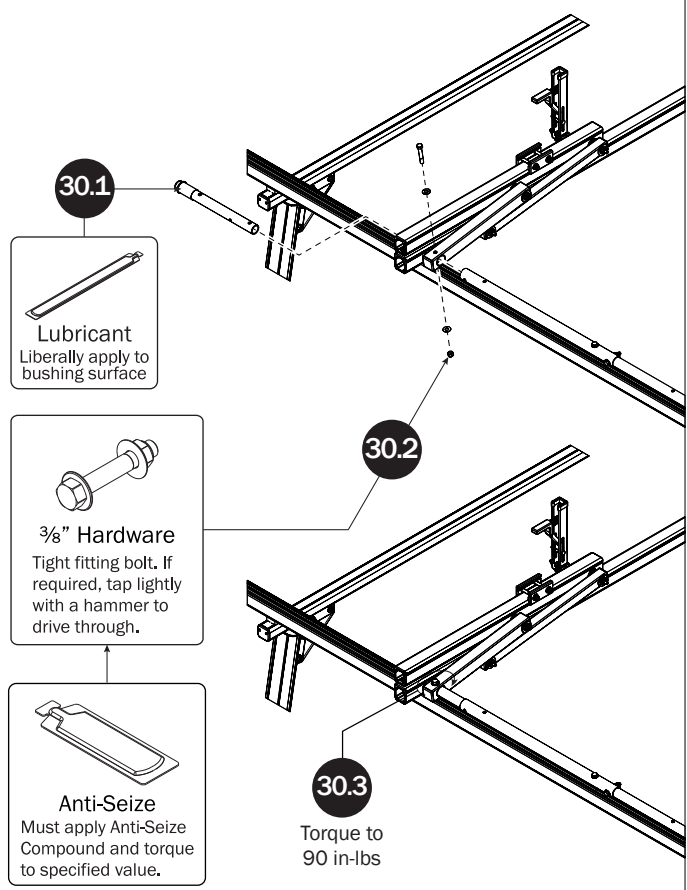

**CONNECTING BAR FASTENERS**

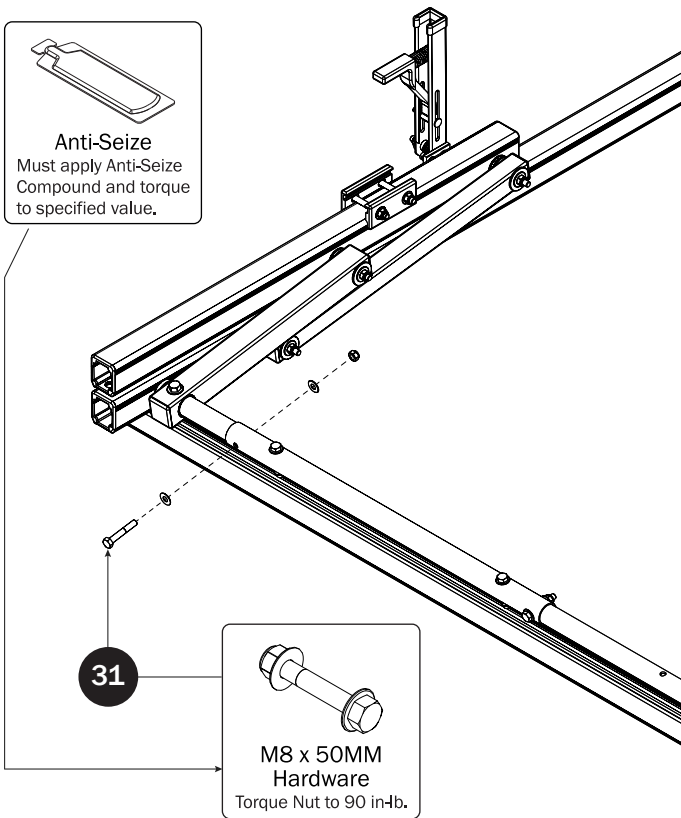

**Z POSTS**

SEE QUICK START GUIDE FOR ADJUSTMENTS

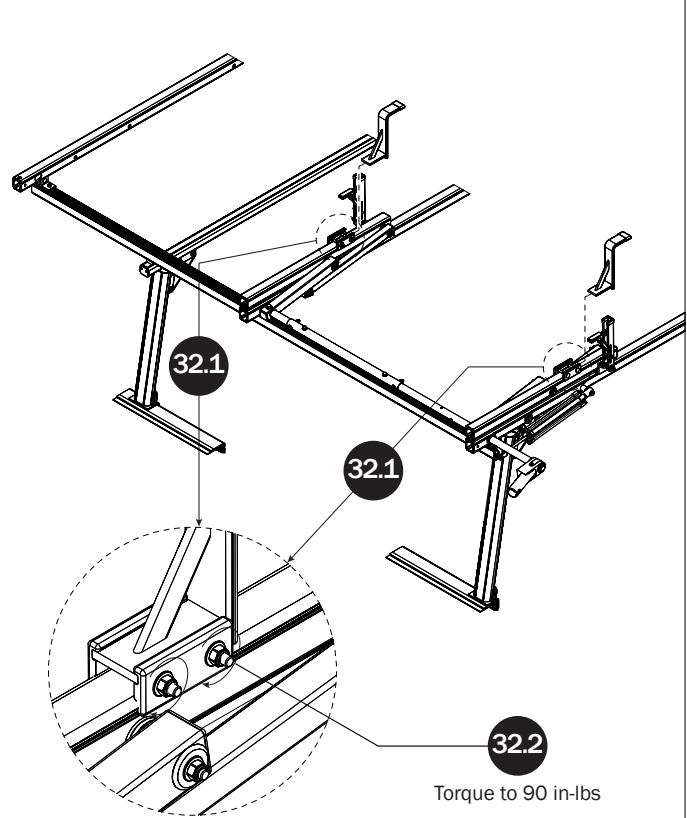

**L POSTS**

SEE QUICK START GUIDE FOR ADJUSTMENTS

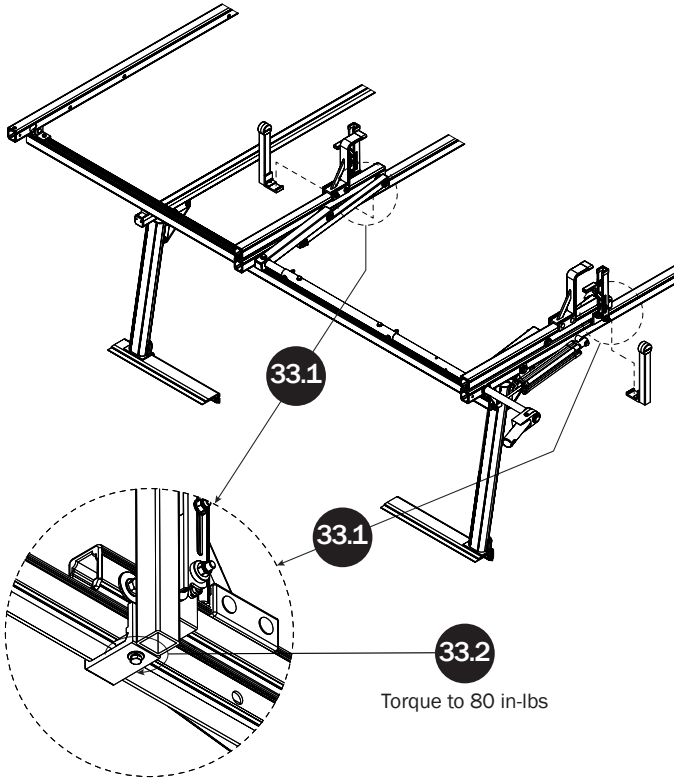

**DRIVE SHAFT SEALING**

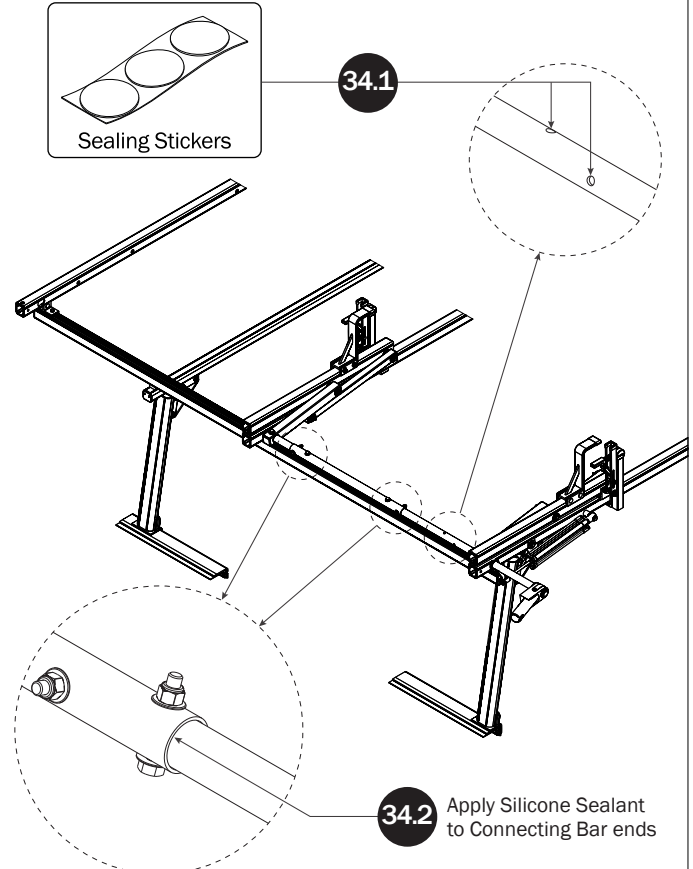

**CYLINDER ADJUSTMENT**

Adjust the Cylinder Flow Control Screw to allow approximately 3 seconds time for the ladder to glide down when operating the loaded Ladder Rack.

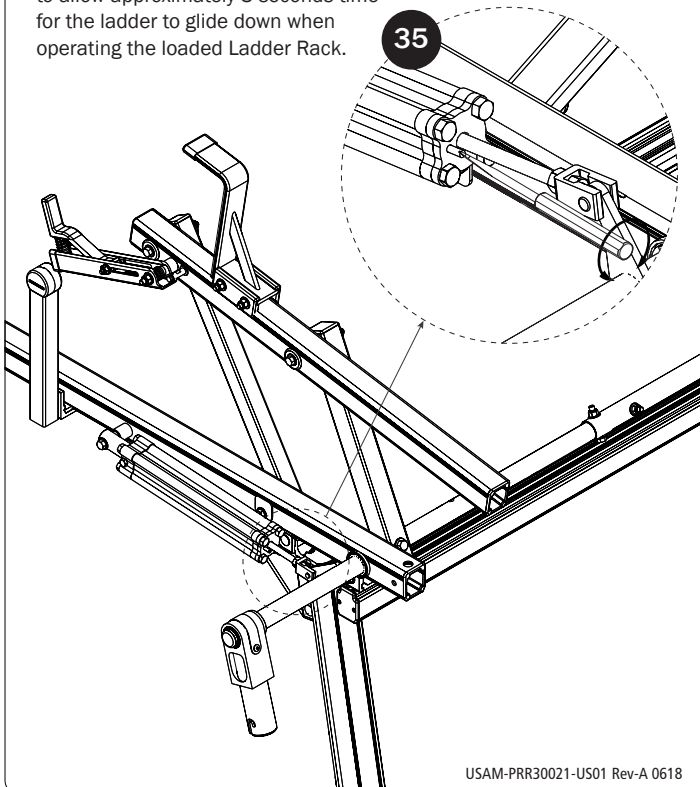

USAM-PRR30021-US01 Rev-A 0618