

PRIME DESIGN™

A Safe Fleet Brand

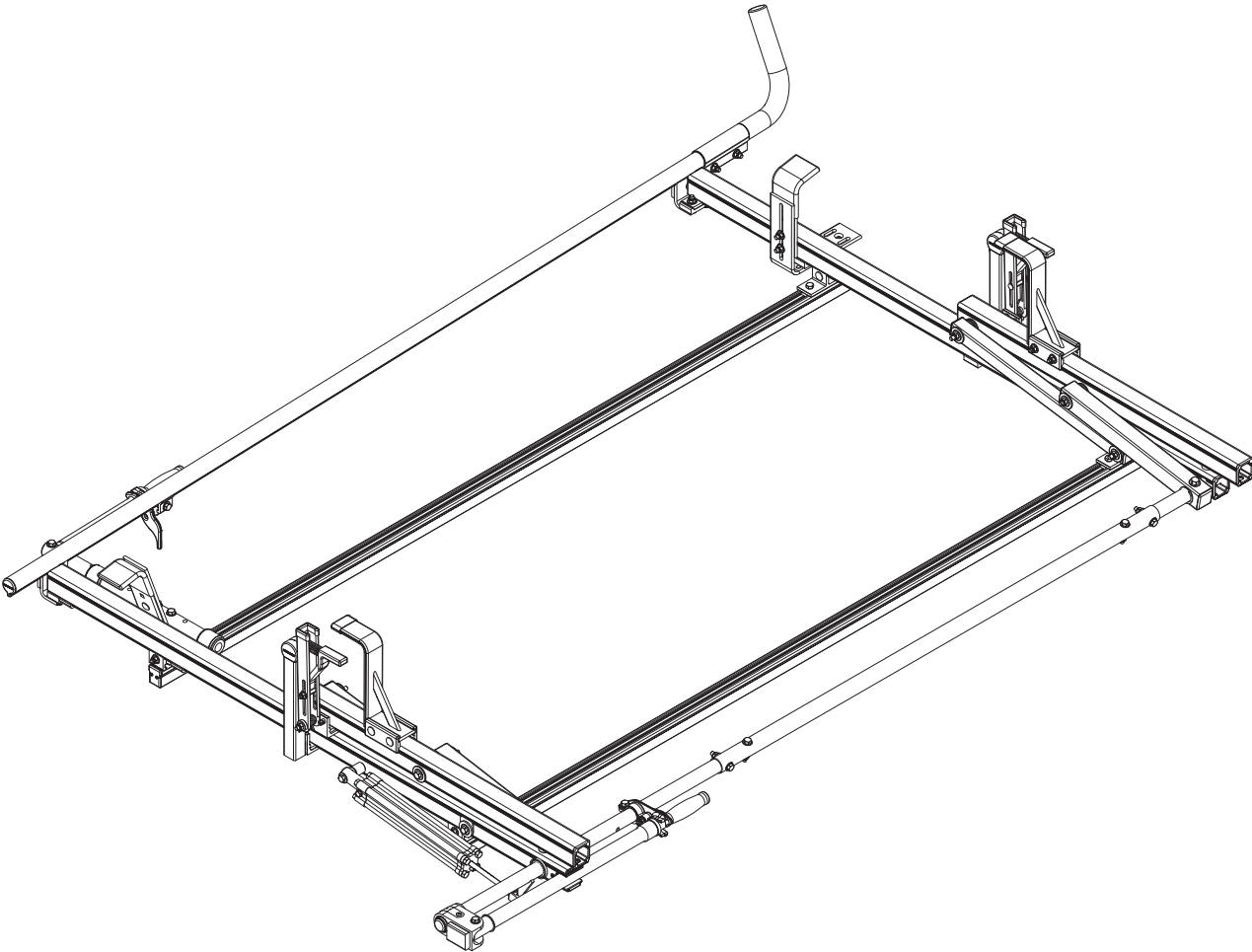

PCR 6000A

CONTENTS OVERVIEW

INSTALLER NOTE: Mounting Hardware or Brackets to attach this rack to a vehicle roof or cap are not included in this kit, and must be purchased separately.

To purchase Mounting Hardware or Brackets, please contact Prime Design Sales & Support.

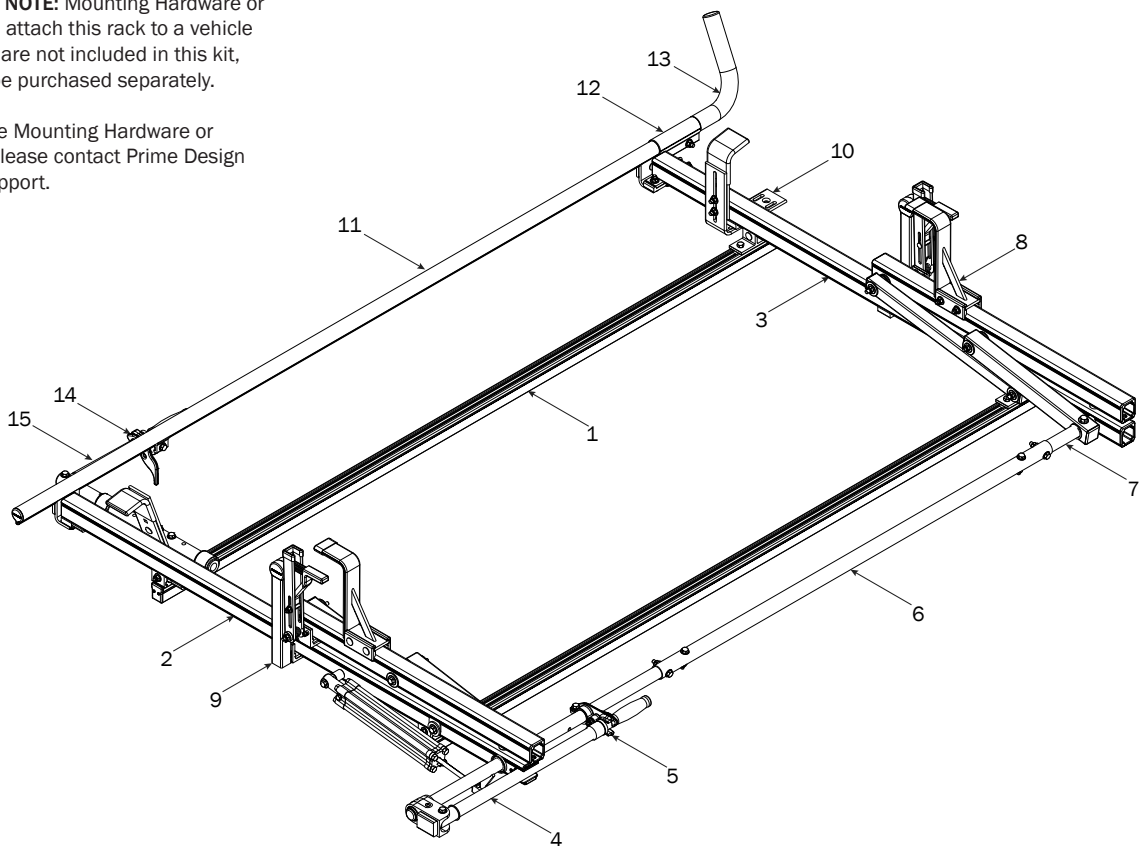

1—FBM-0001 (Qty 1)
Channels with hardware



Channels (2X)



Screws (8X)



End Caps (4X)



Brackets (4X)

2—Rear Crossbar Assembly..... (Qty 1)

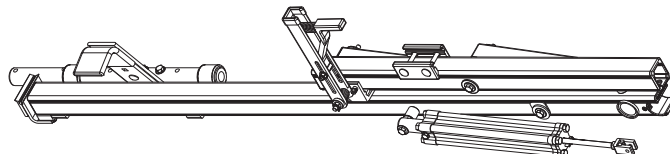

3—Front Crossbar Assembly (Qty 1)

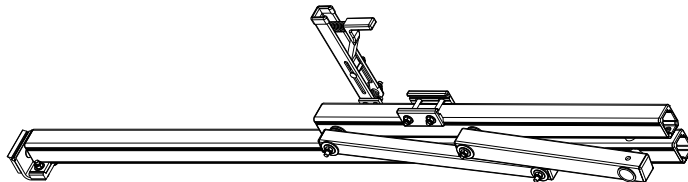

4—Rear Drive Shaft..... (Qty 1)
Right Hand, 34.00"

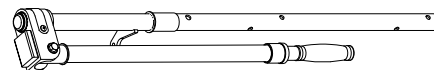

5—Handle Latch Assembly (Qty 1)



6—Connecting Bar..... (Qty 1)
4.00'

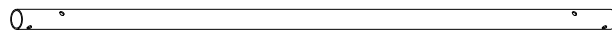

7—Front Drive Shaft (Qty 1)
B Version, 35.75"

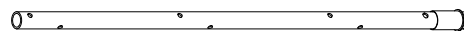

8—Z Post (Qty 2)
Adjustable, 7.25"

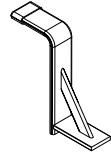

9—L Post (Qty 2)
US3, Square Cap, 11.25"

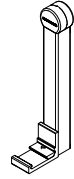

10—Front Hook Assembly (Qty 1)

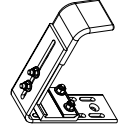

11—Clamp Down Tube (Qty 1)
80.00"

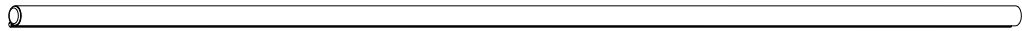

12—Quick Clamp Tube Splice Assembly (Qty 1)
5.00"



13—Removeable Horn with Cap (Qty 1)
15.00"

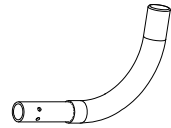

14—Clamp Down Handle Latch Assembly (Qty 1)



15—Clamp Down Handle Assembly (Qty 1)

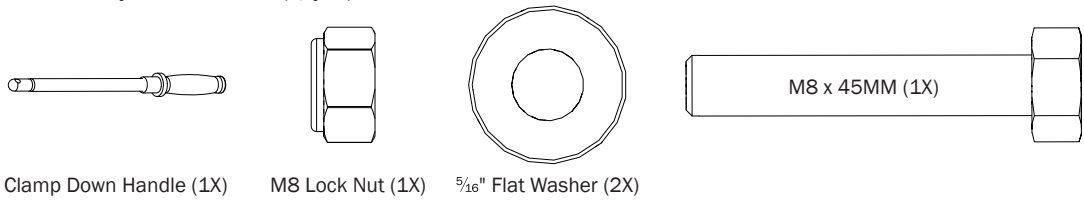

HKT-8163-Rotation Hardware Kit

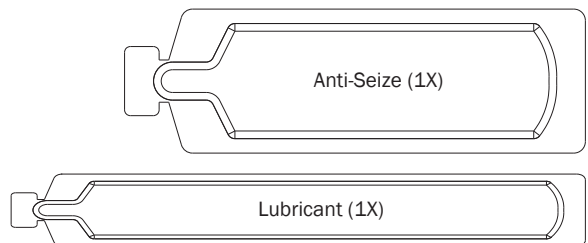
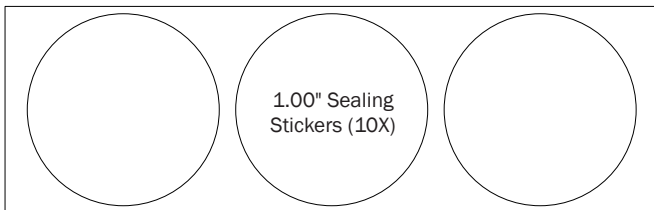
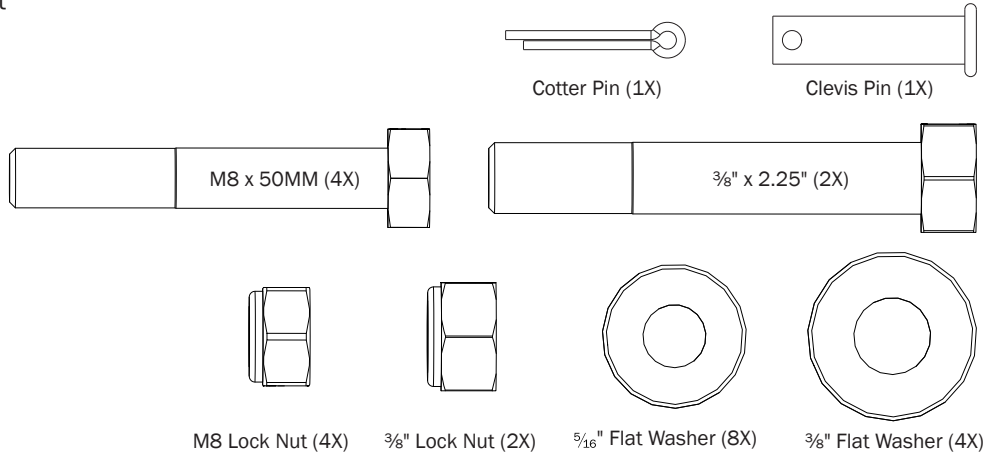

FBM-0001 FLUSH CHANNELS TO PRE-INSTALLED MOUNTING BRACKETS

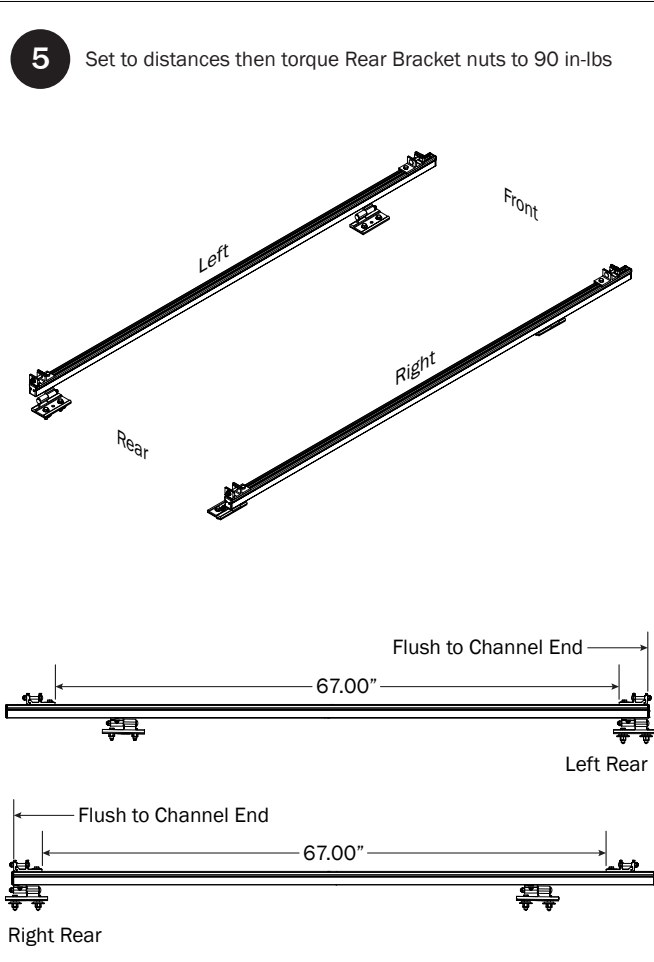
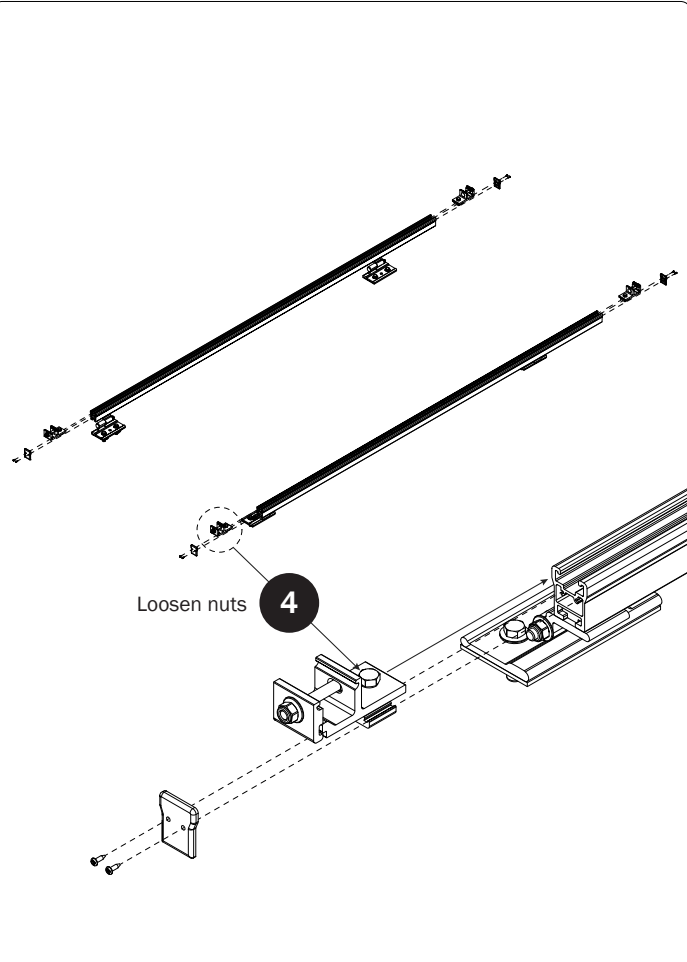
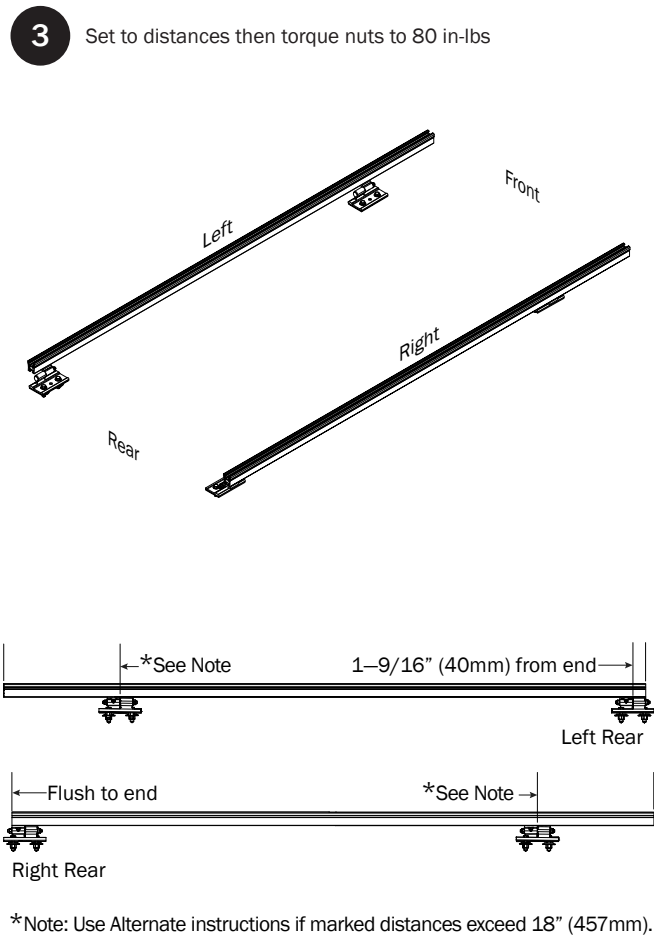
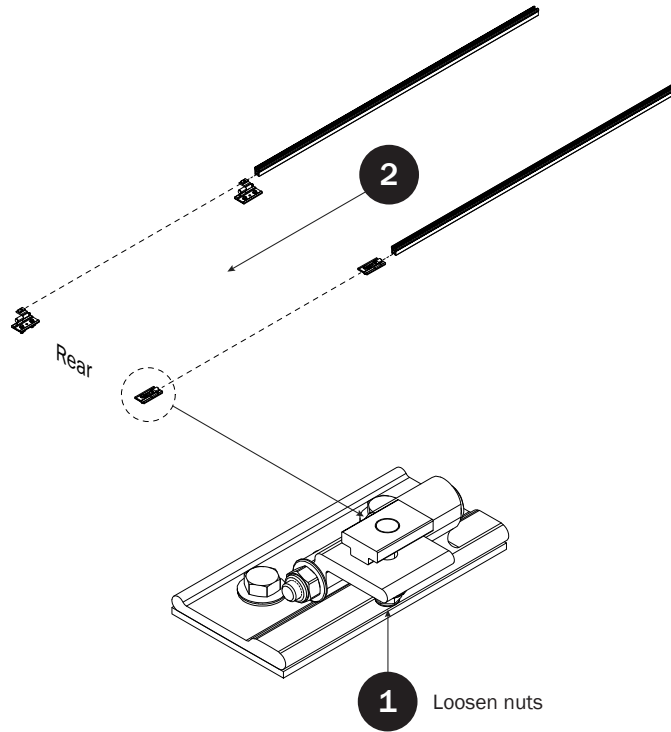

FBM-0001 ALTERNATE
CHANNELS TO PRE-INSTALLED
MOUNTING BRACKETS

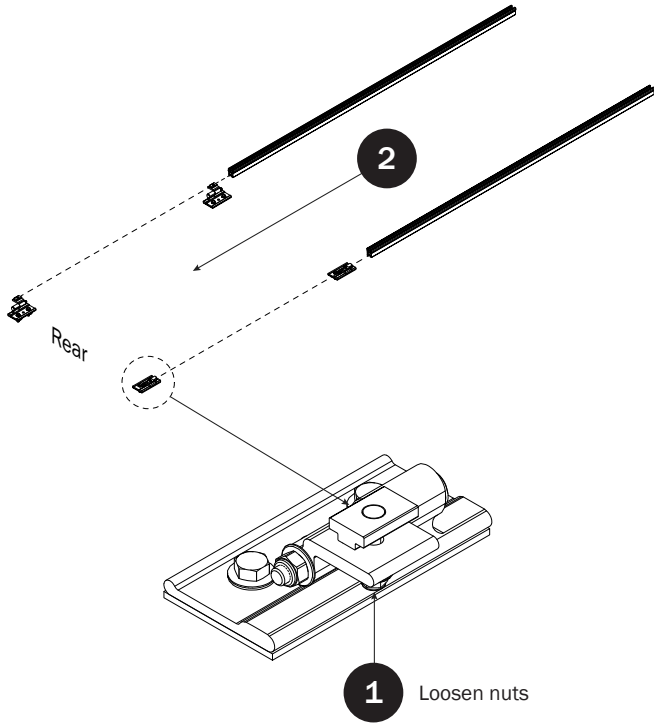

3 Set to distances then torque nuts to 80 in-lbs

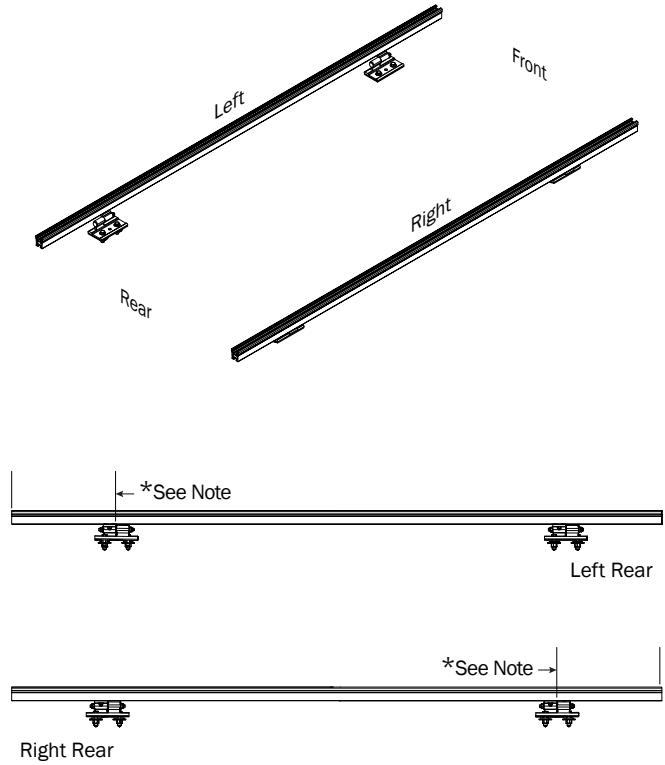

* Move Channels rearward until front distance no longer exceeds 18" (457mm).

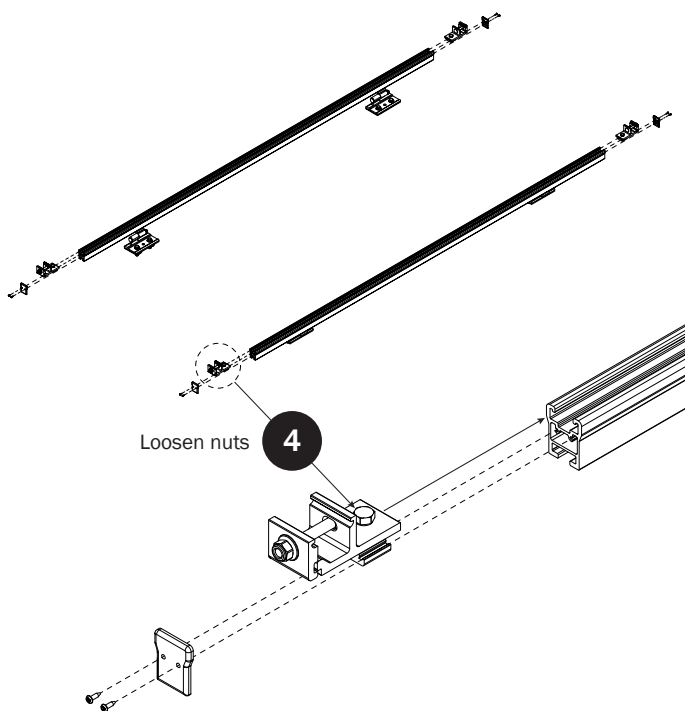

5 Set to distances then torque Rear Bracket nuts to 90 in-lbs

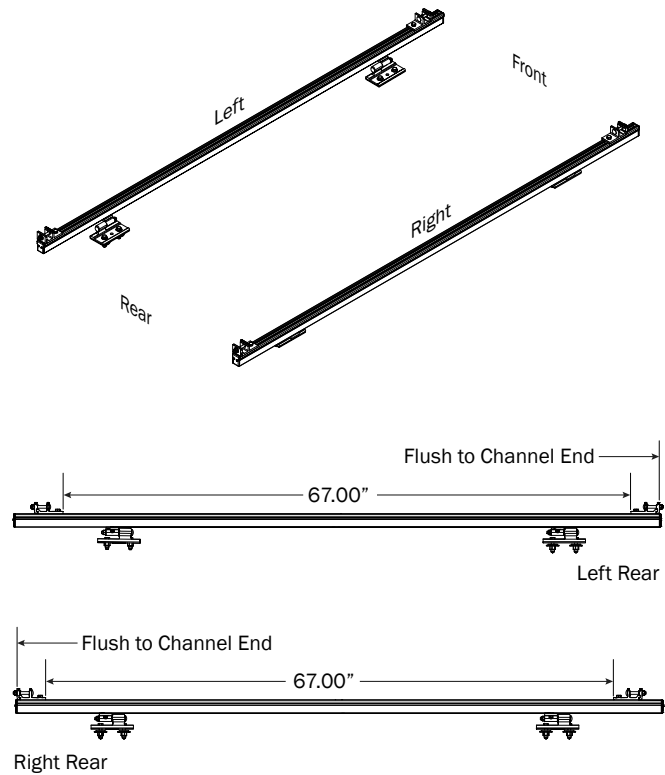

FBM-0001 SLOPED TYPICAL CHANNELS TO PRE-INSTALLED MOUNTING BRACKETS

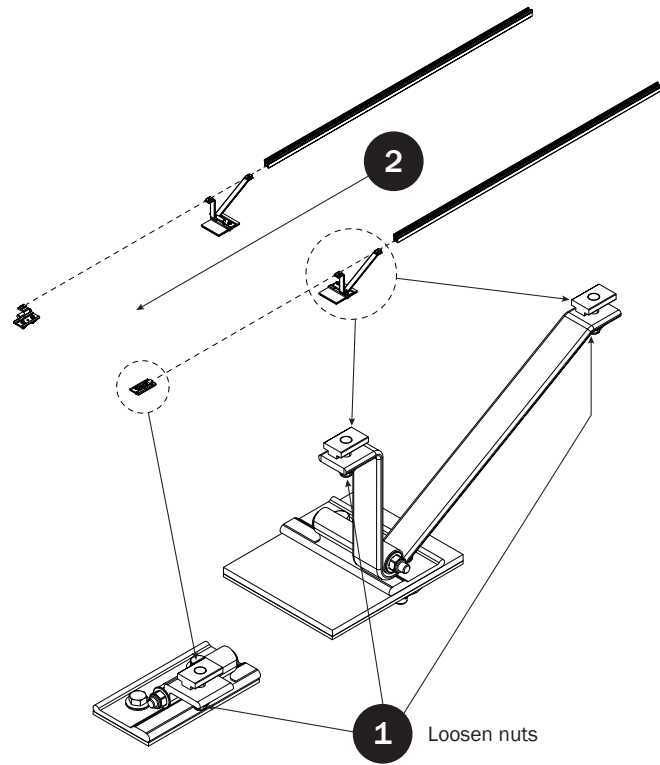

3 Set to distances then torque nuts to 80 in-lbs

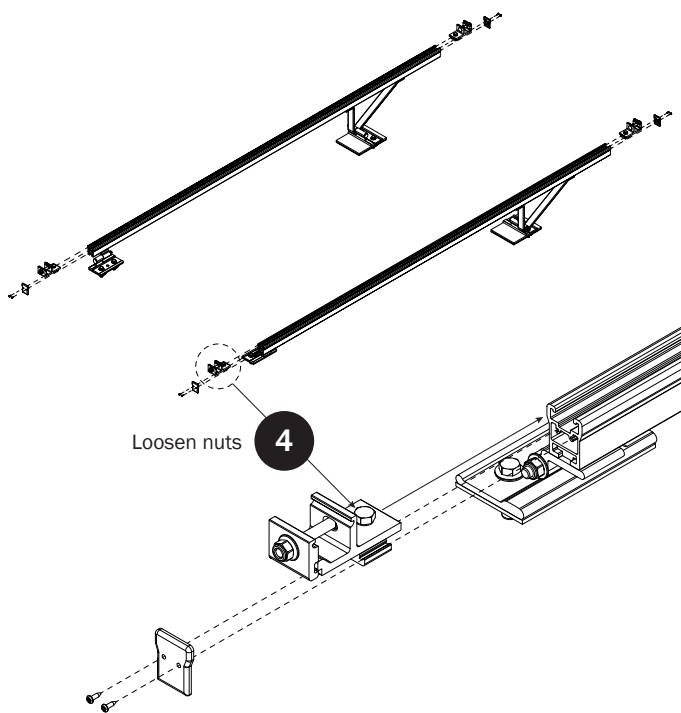
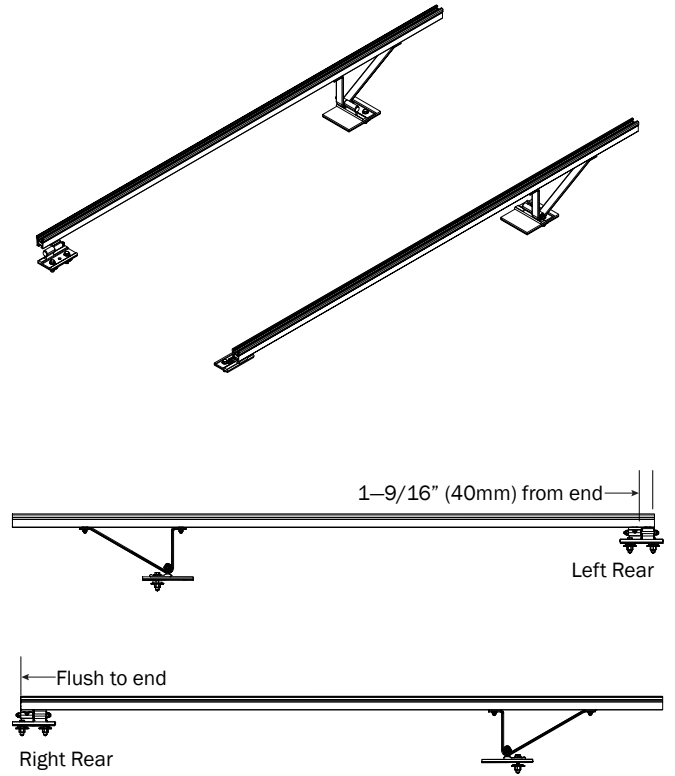

5 Set to distances then torque nuts to 90 in-lbs

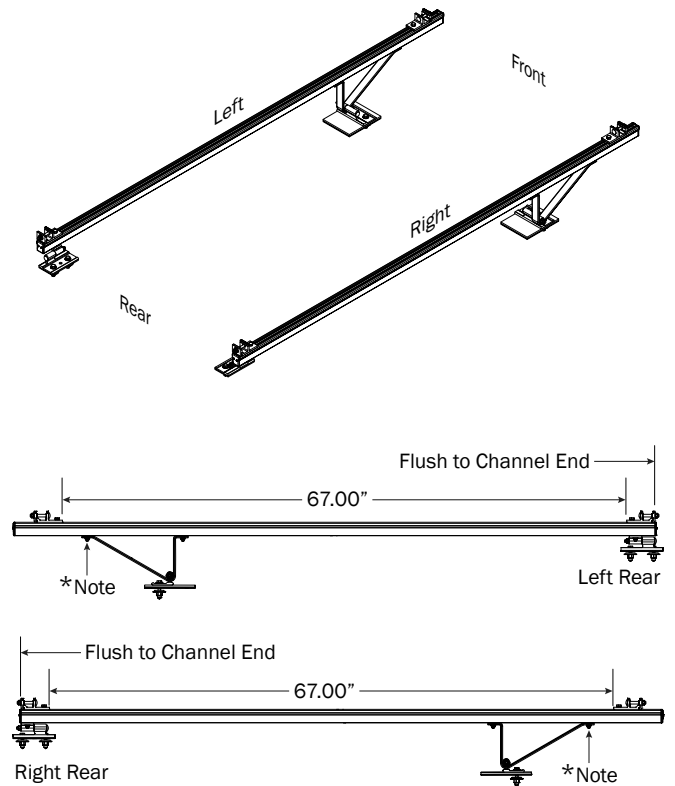

*Note: Use Alternate instructions if mounting point is beyond end of Channel.

FBM-0001 SLOPED ALTERNATE CHANNELS TO PRE-INSTALLED MOUNTING BRACKETS

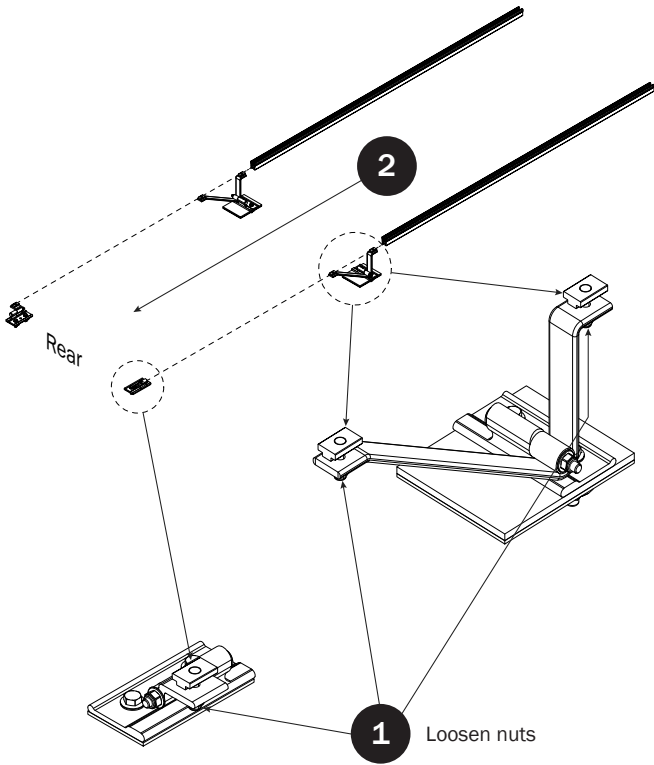

3 Set to distances then torque nuts to 80 in-lbs

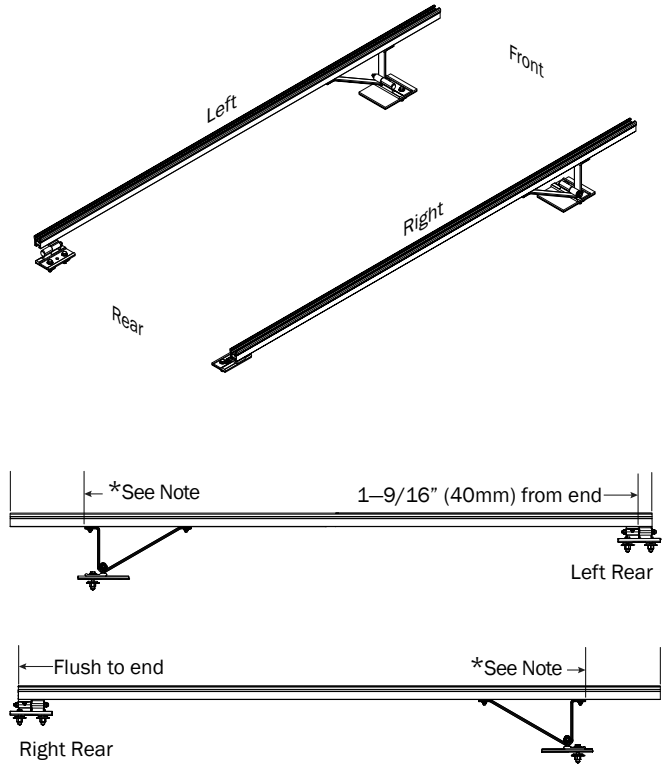

*Note: Use Sloped Typical instructions if front distance exceeds 18" (457mm).

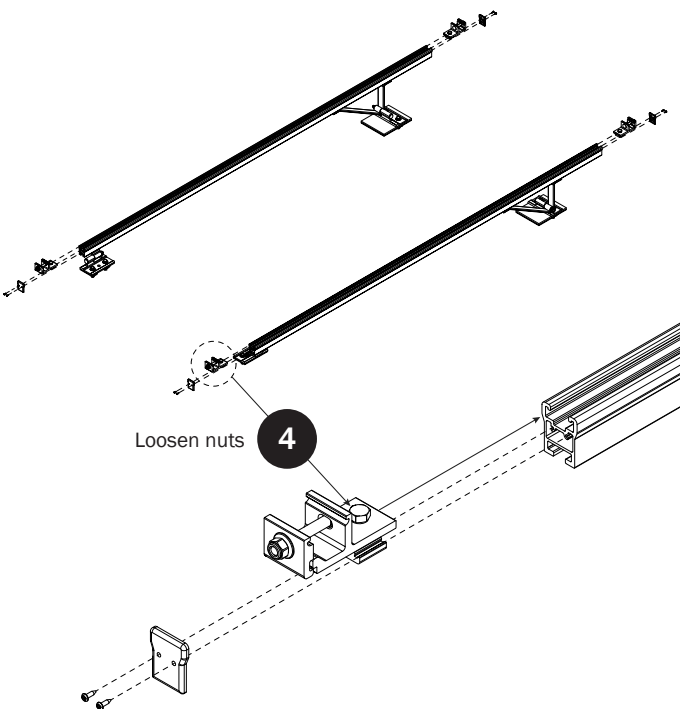

5 Set to distances then torque nuts to 90 in-lbs

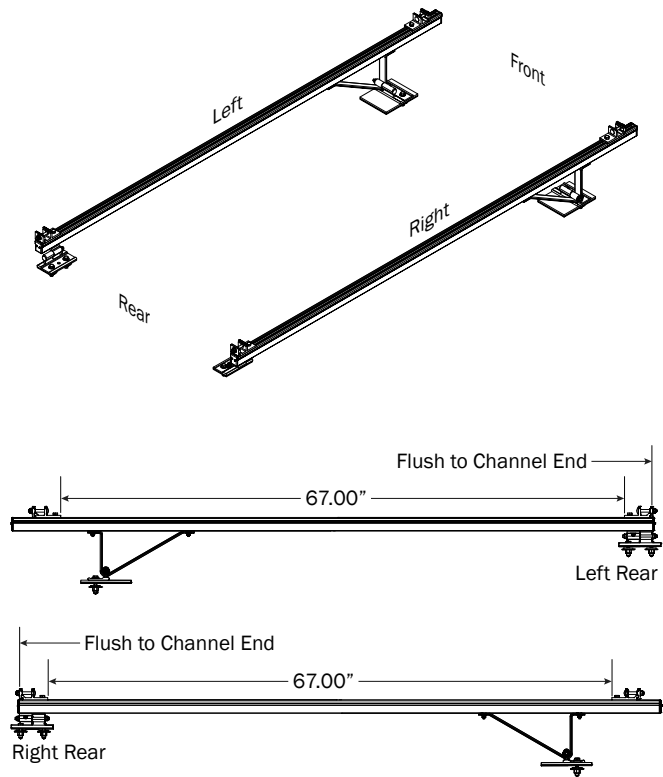

RIGHT ROTATION ASSEMBLY

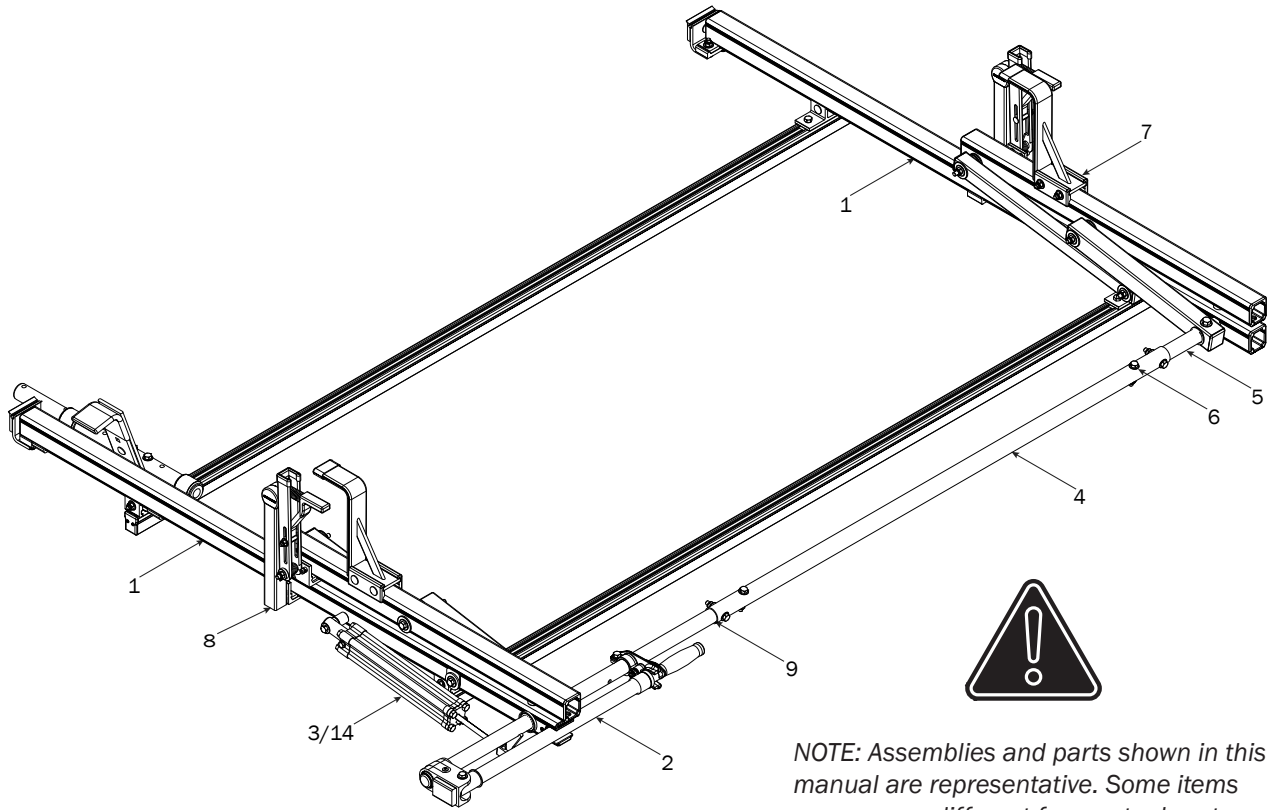

NOTE: Assemblies and parts shown in this manual are representative. Some items may appear different from actual parts, assemblies, or components received.

CROSSBARS

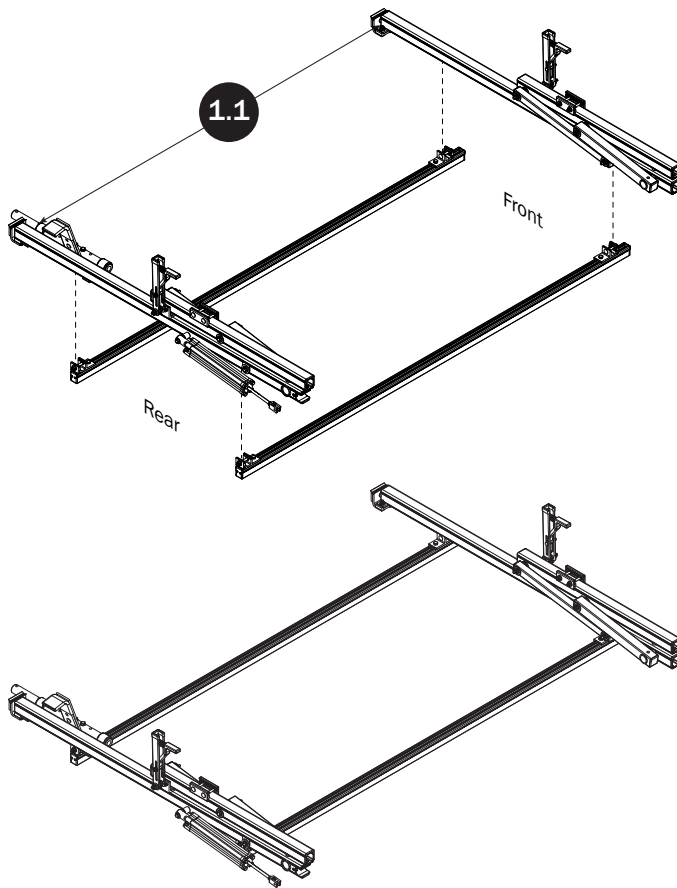

CROSSBAR ADJUSTMENT

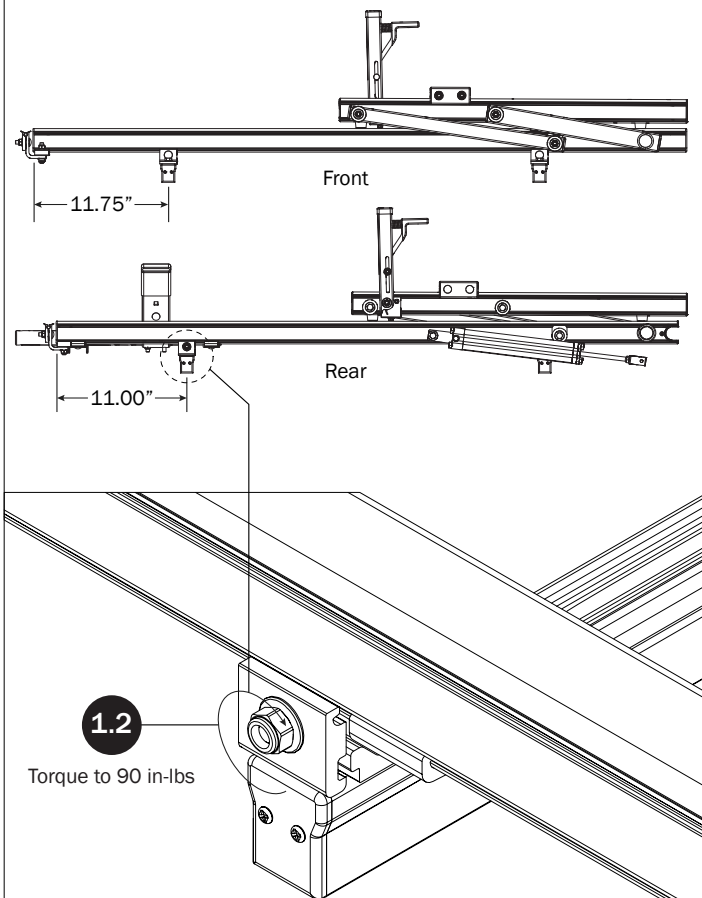

REAR DRIVE SHAFT

NOTE: For instructional clarity, the FBM Mounting System will not be shown for the remainder of this Assembly Manual.

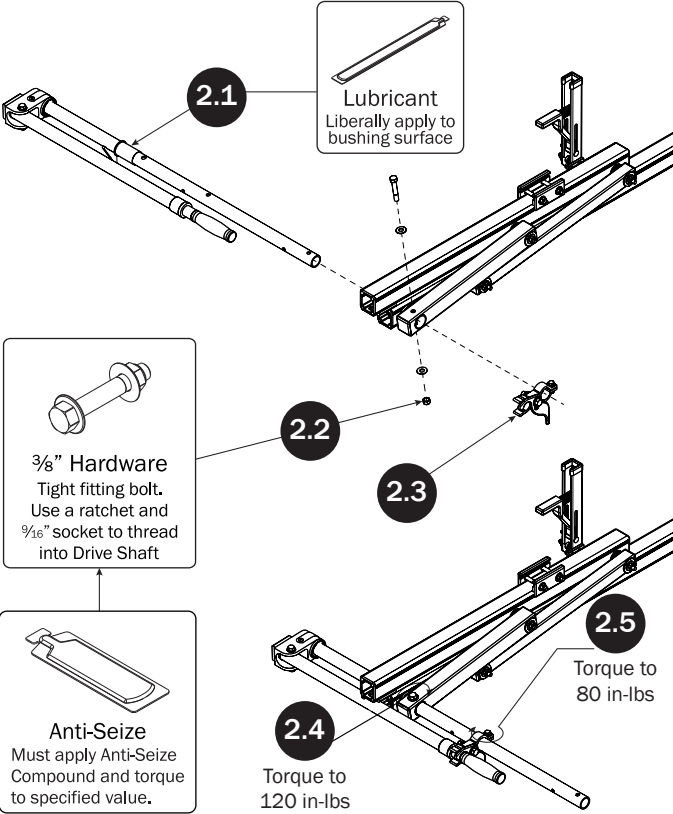

CYLINDER HARDWARE

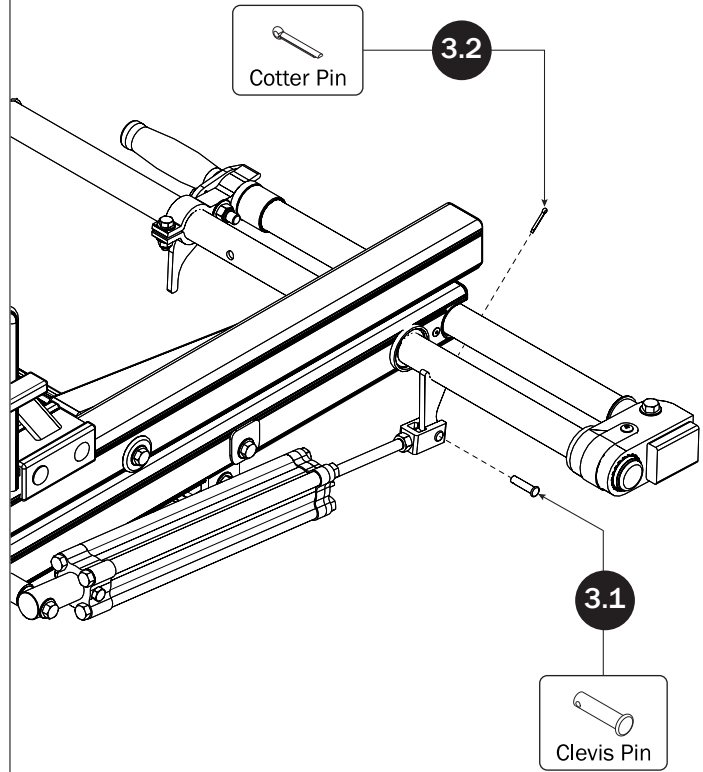

CONNECTING BAR

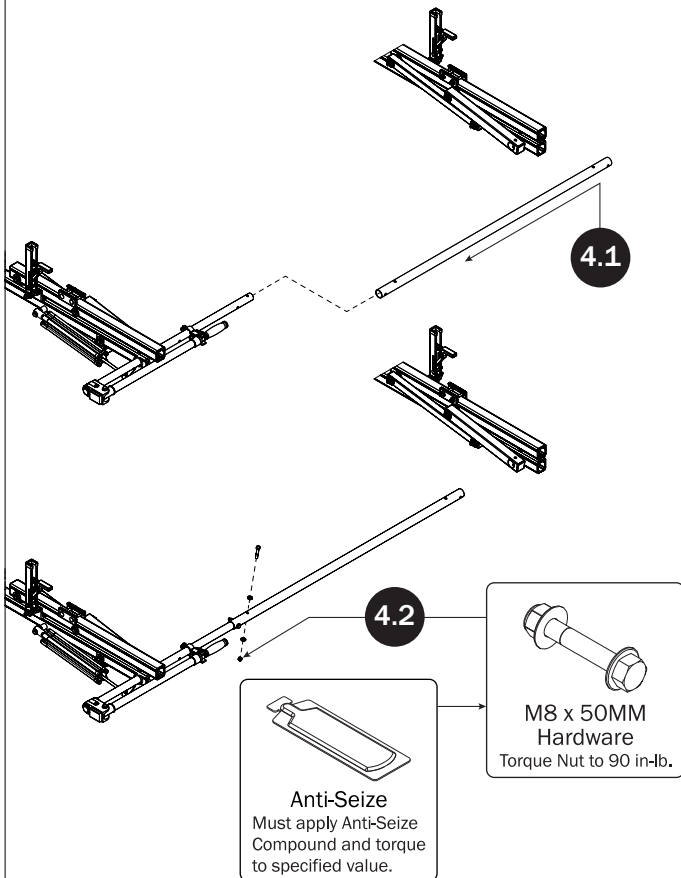

FRONT DRIVE SHAFT

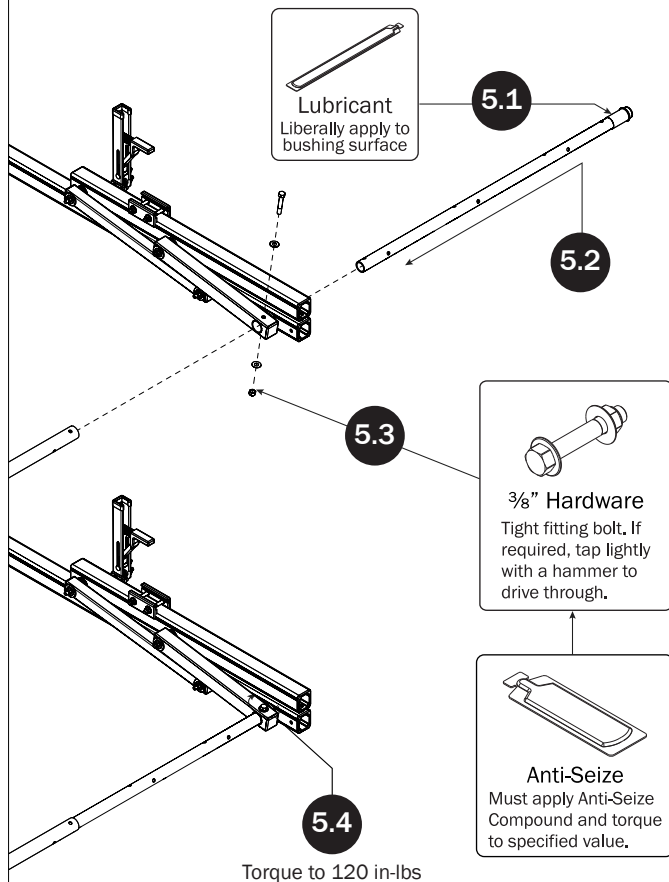

CONNECTING BAR FASTENERS

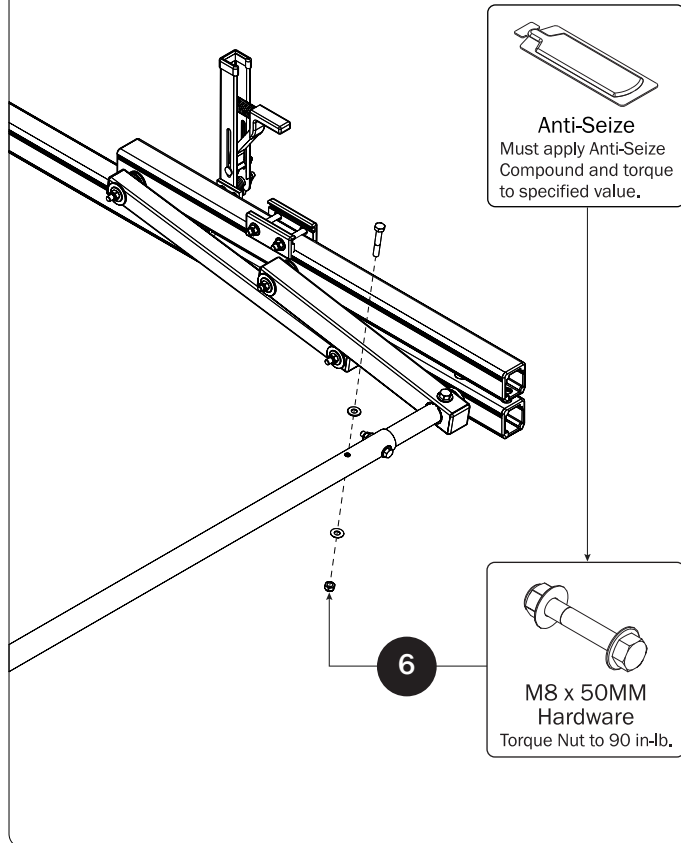

Z POSTS

SEE QUICK START GUIDE FOR ADJUSTMENTS

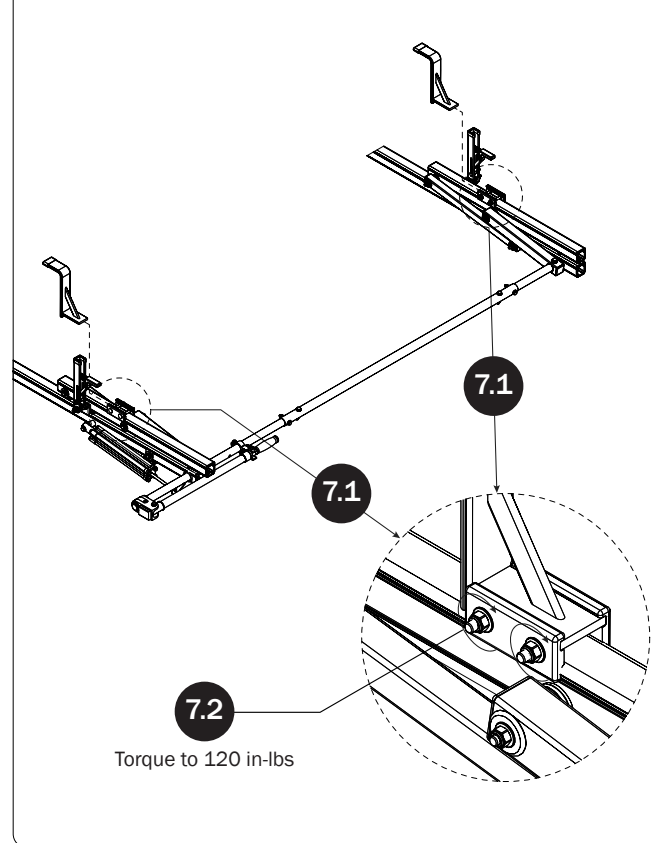

L POSTS

SEE QUICK START GUIDE FOR ADJUSTMENTS

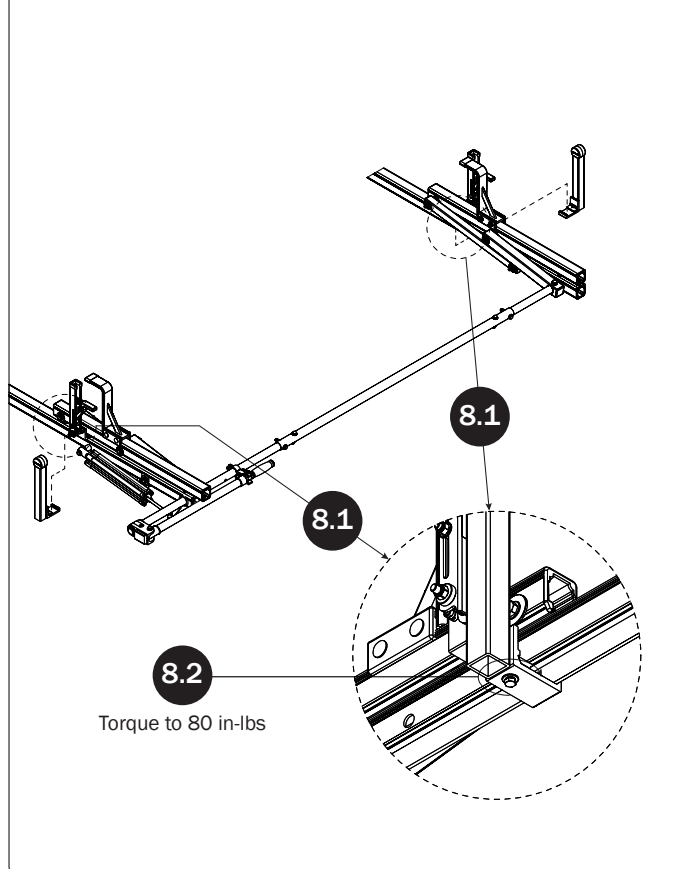

DRIVE SHAFT SEALING

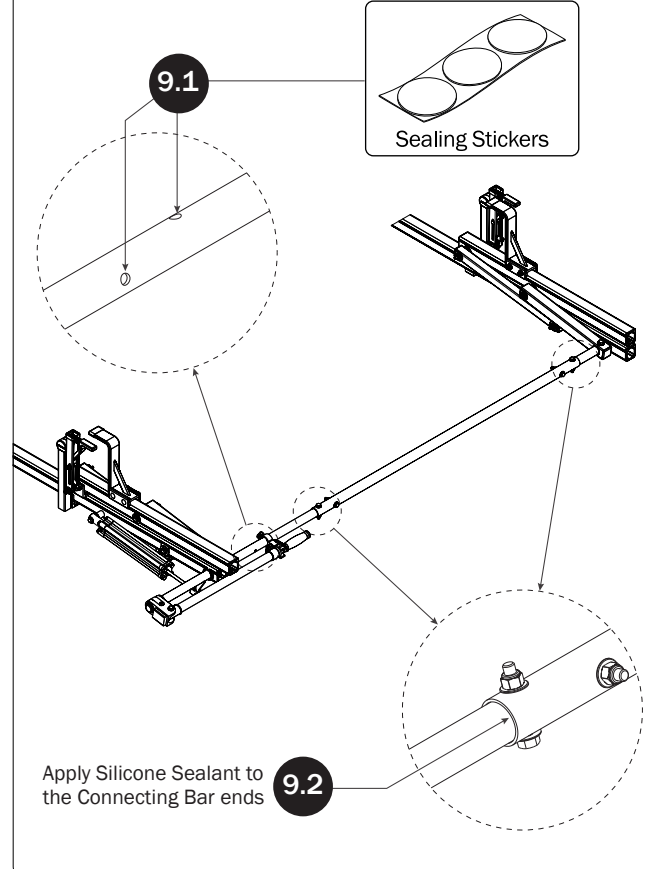

LEFT CLAMP DOWN

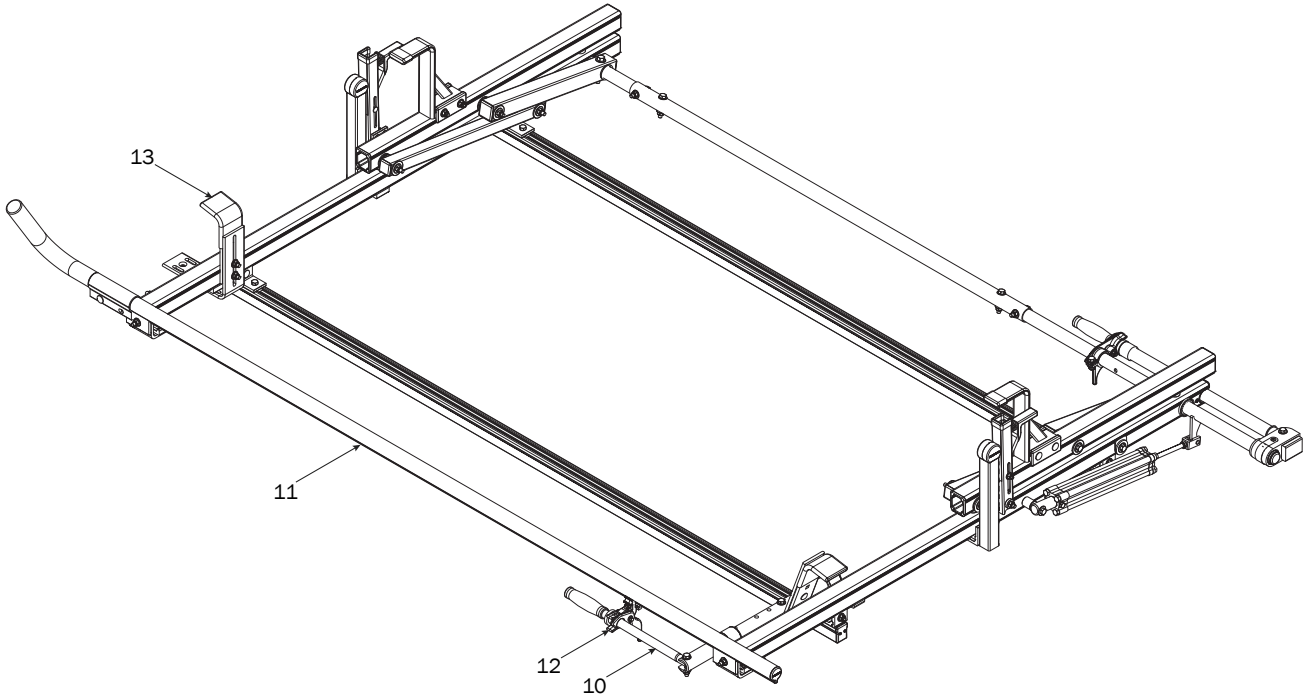

CLAMP DOWN HANDLE

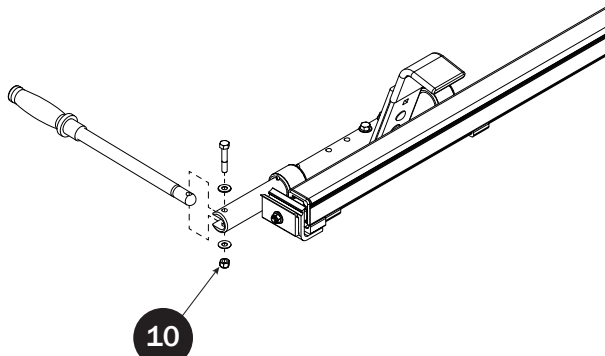

10



M8 x 45MM
Hardware
Torque Nut to 90 in-lb.

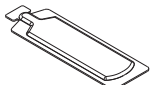

Anti-Seize
Must apply Anti-Seize
Compound and torque
to specified value.

CLAMP DOWN TUBE

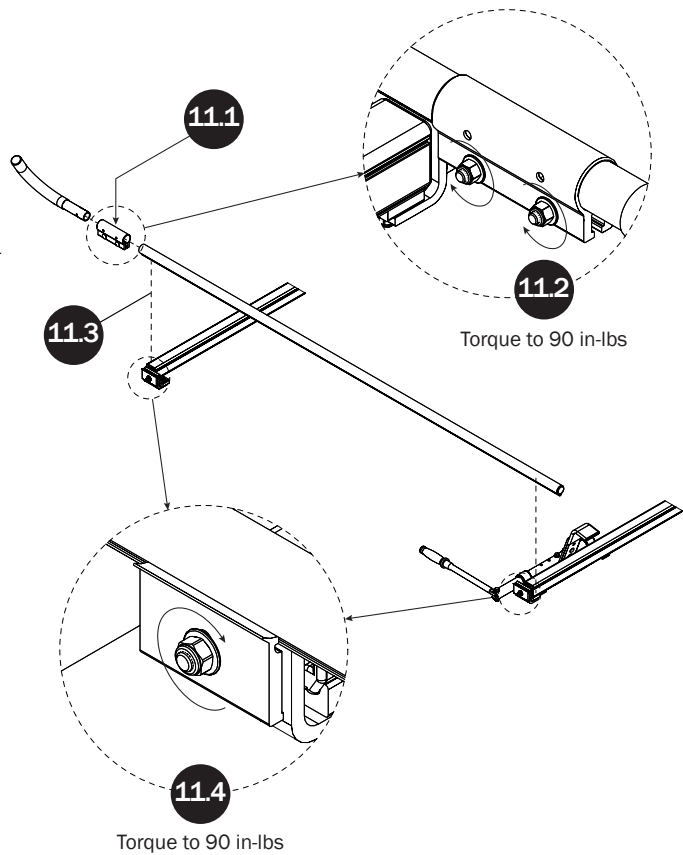

HANDLE LATCH

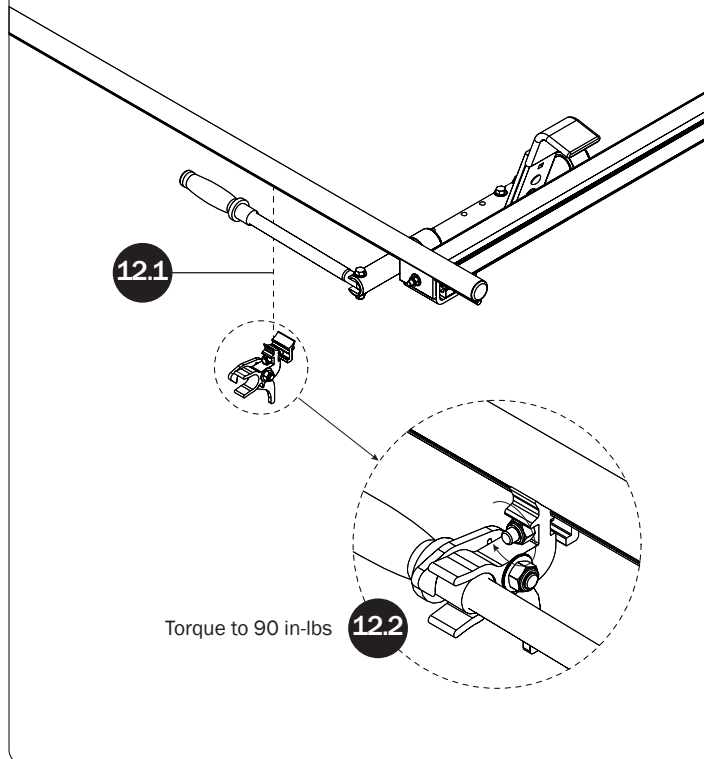

FRONT LADDER HOOK SEE QUICK START GUIDE FOR ADJUSTMENTS

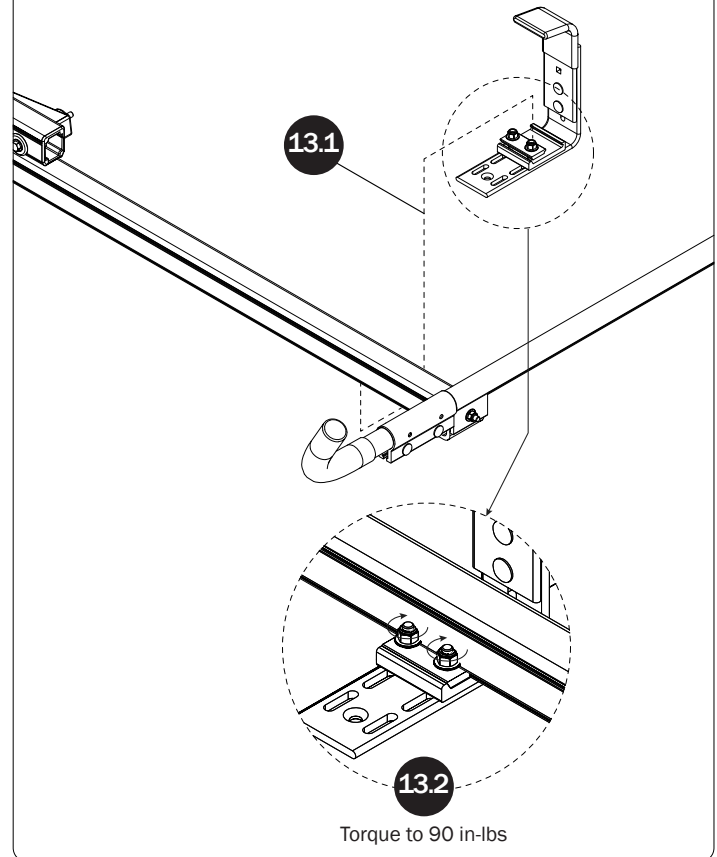

CYLINDER ADJUSTMENT

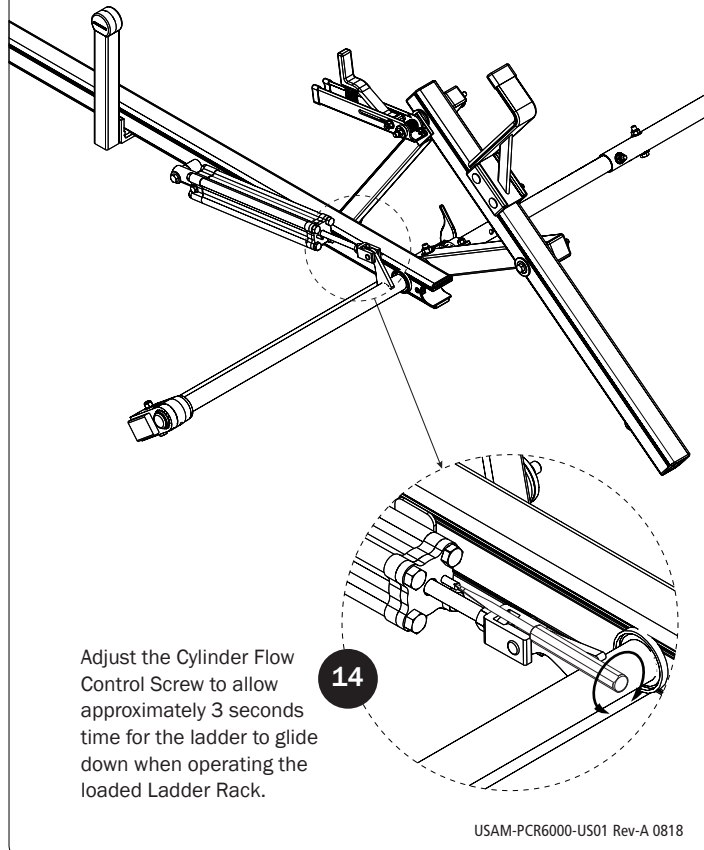

USAM-PCR6000-US01 Rev-A 0818