

# PRIME DESIGN™

A Safe Fleet Brand

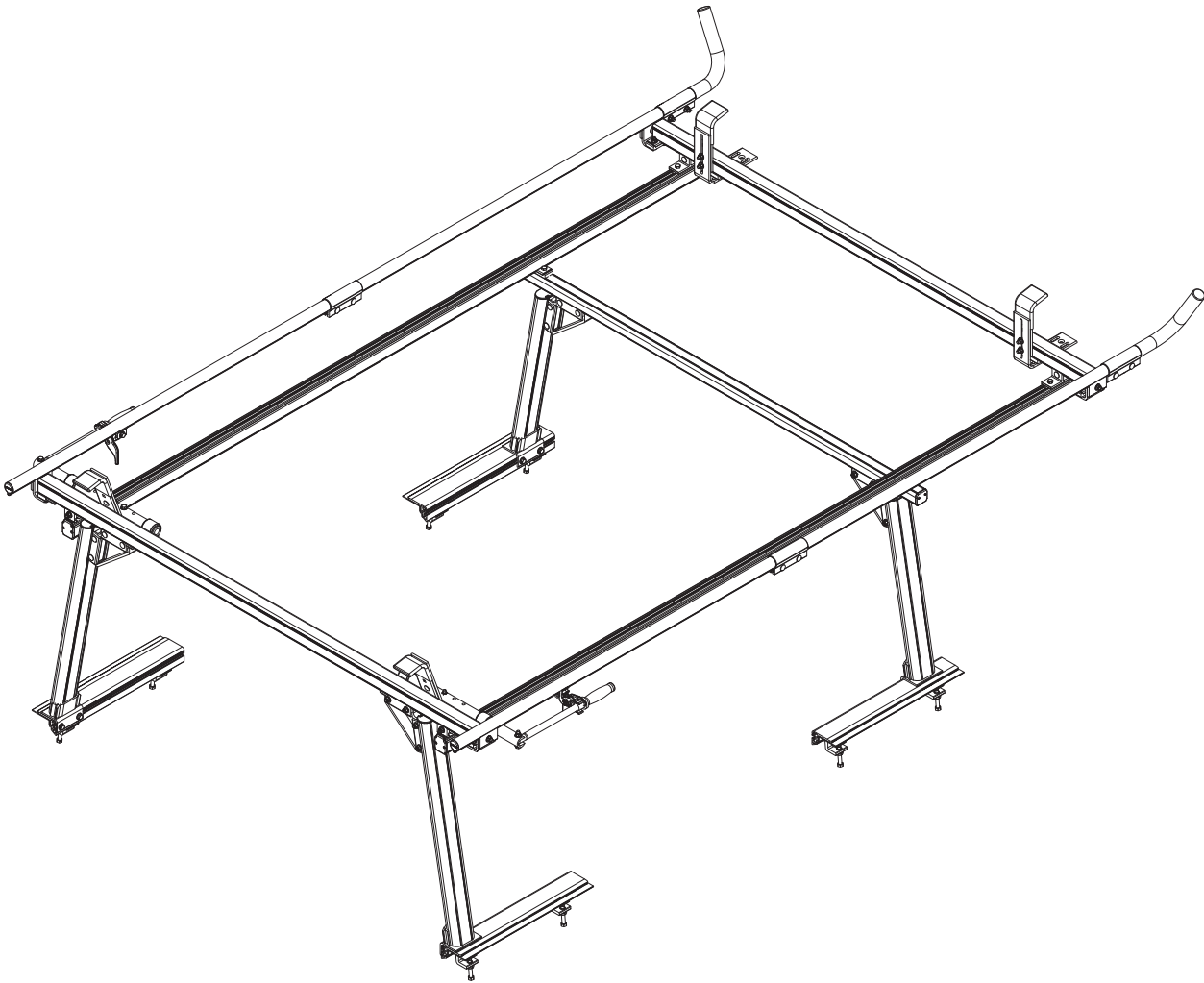

PCC 0021

PRIME DESIGN, A SAFE FLEET BRAND

Address: 580 Opperman Drive, Eagan, MN 55123 • Toll Free: 1.8.PRIME.RACK

Fax: 651-552-1799 • Email: [info@primedesign.net](mailto:info@primedesign.net) • Website: [www.primedesign.net](http://www.primedesign.net)

CONTENTS OVERVIEW

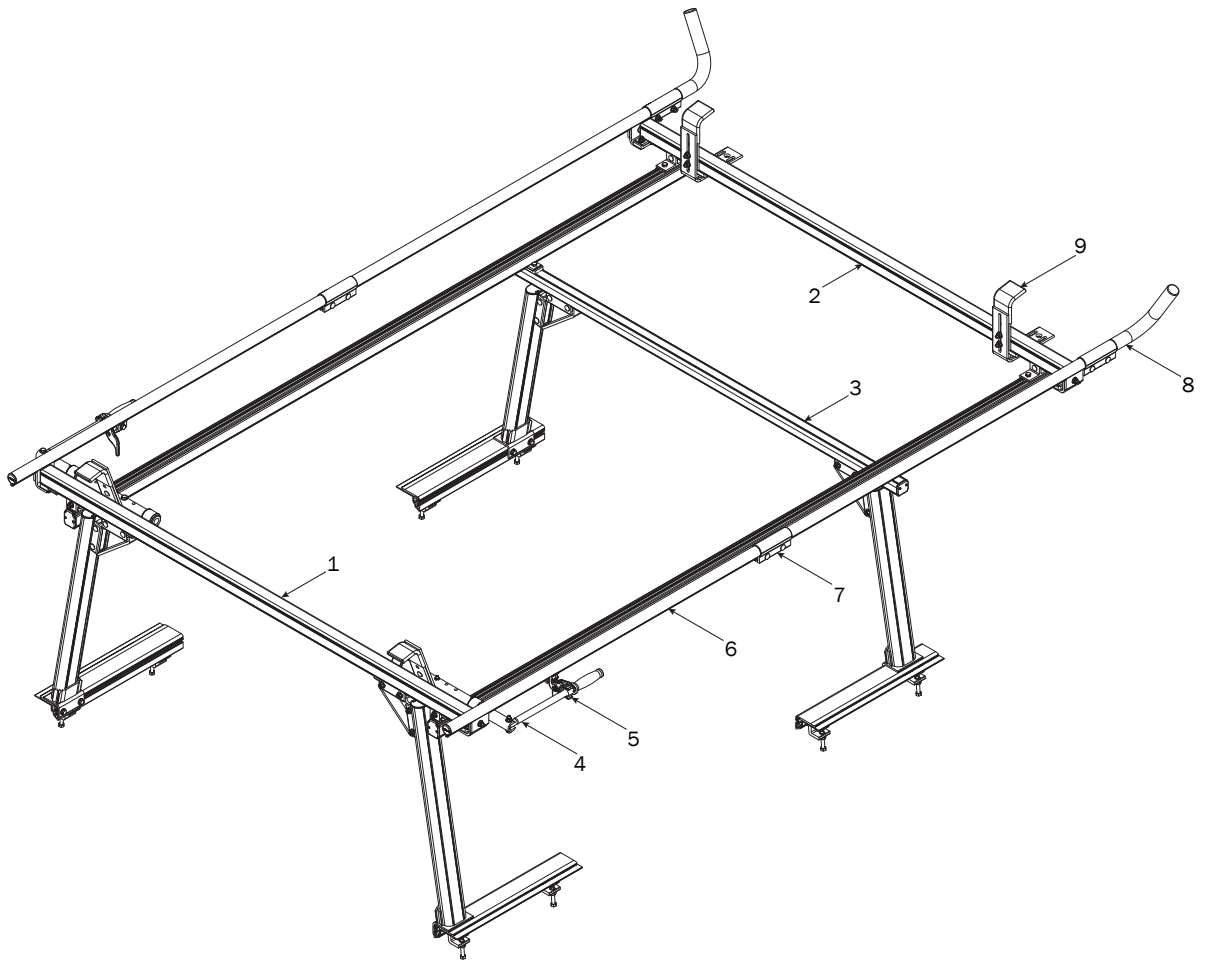

1—Rear Crossbar Assembly..... (Qty 1)



2—Front Crossbar Assembly ..... (Qty 1)



3—FBM-0062..... (Qty 1)  
PTR Suspended ErgoRack Mounting System

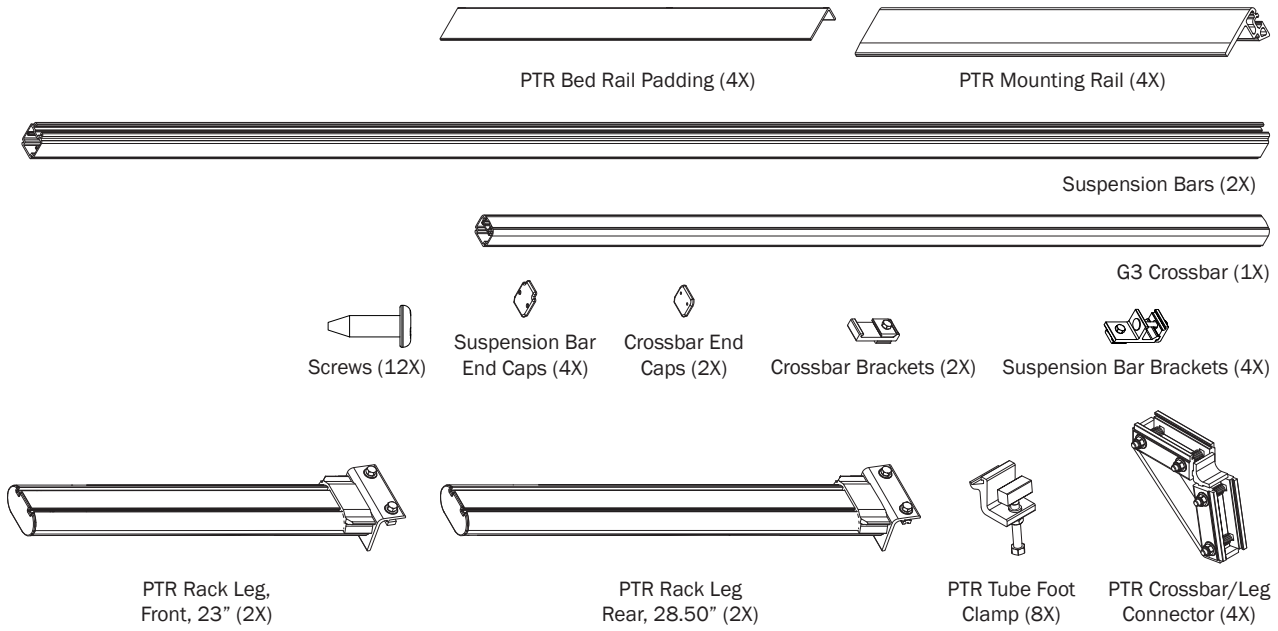

4—Clamp Down Handle Assembly ..... (Qty 2)

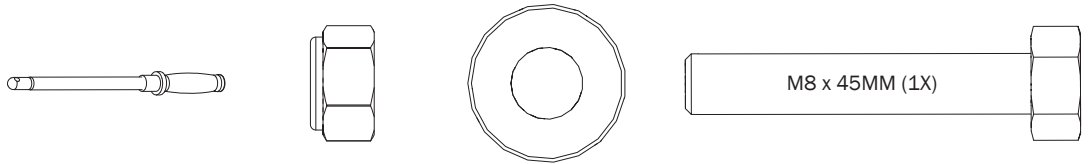

5—Clamp Down Handle Latch Assembly ..... (Qty 2)

6—Clamp Down Tube ..... (Qty 4)  
52.00"

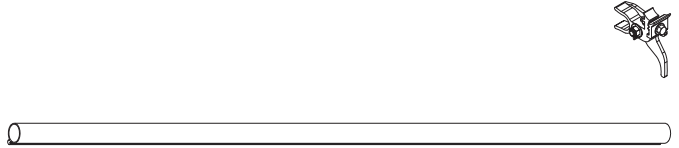

7—Quick Clamp Tube Splice Assembly ..... (Qty 4)  
5.00"

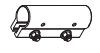

8—Removeable Horn with Cap ..... (Qty 2)  
15.00"

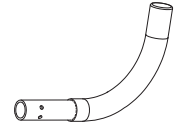

9—Front Hook Assembly ..... (Qty 2)

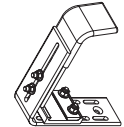

**FBM-0062 ASSEMBLY SEQUENCE**

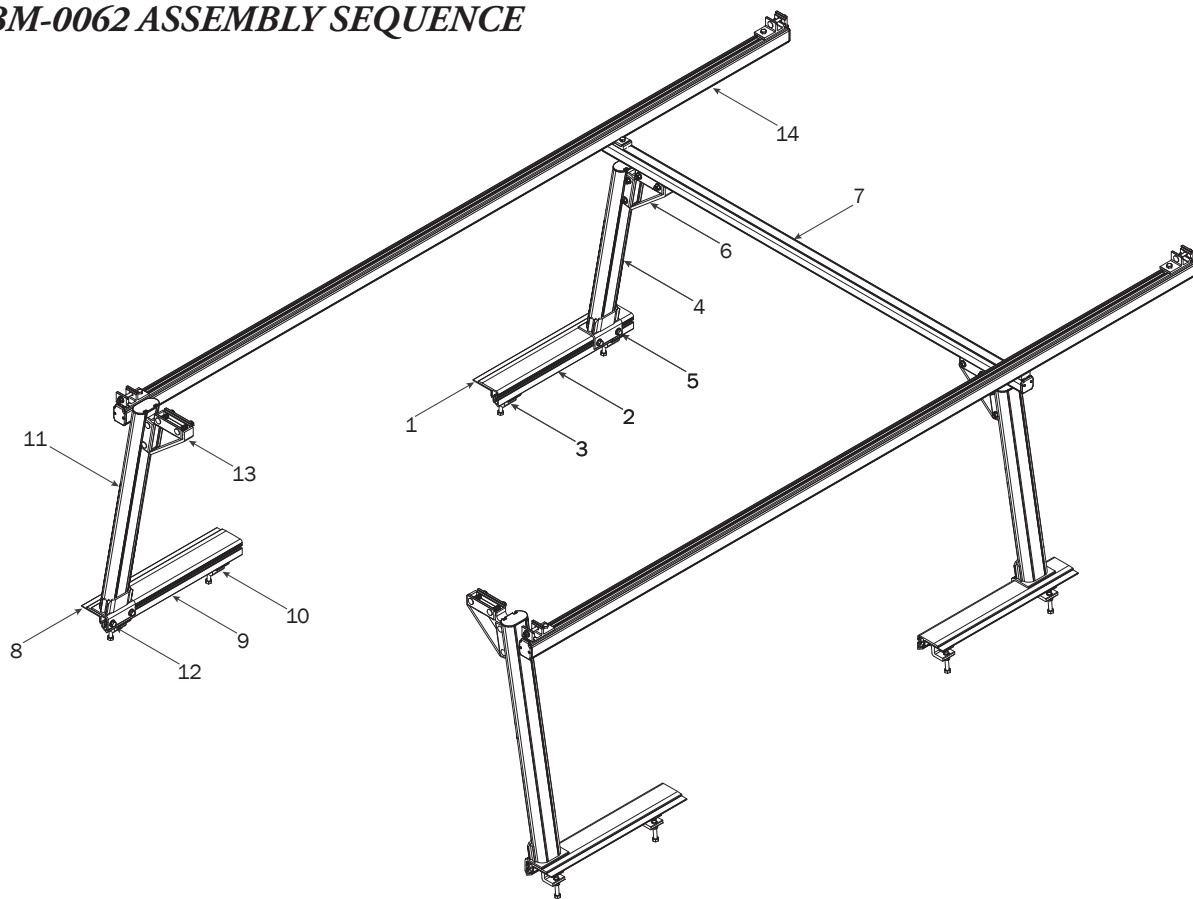

**1** Place the PTR Foot Pad onto the truck's bed rail.

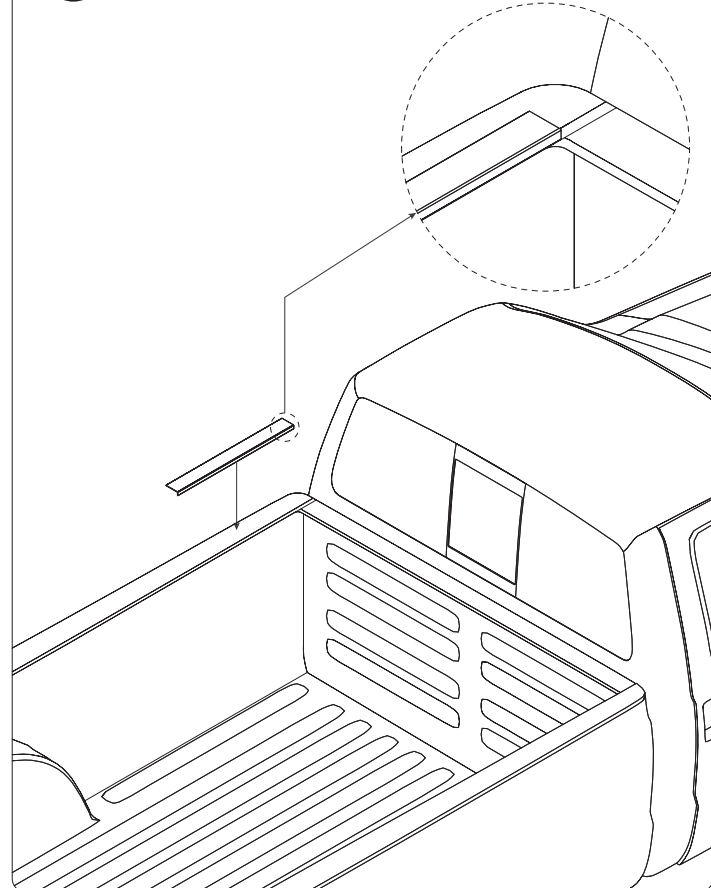

**2** Place the PTR Tube Foot on top of the bed rail Foot Pad.

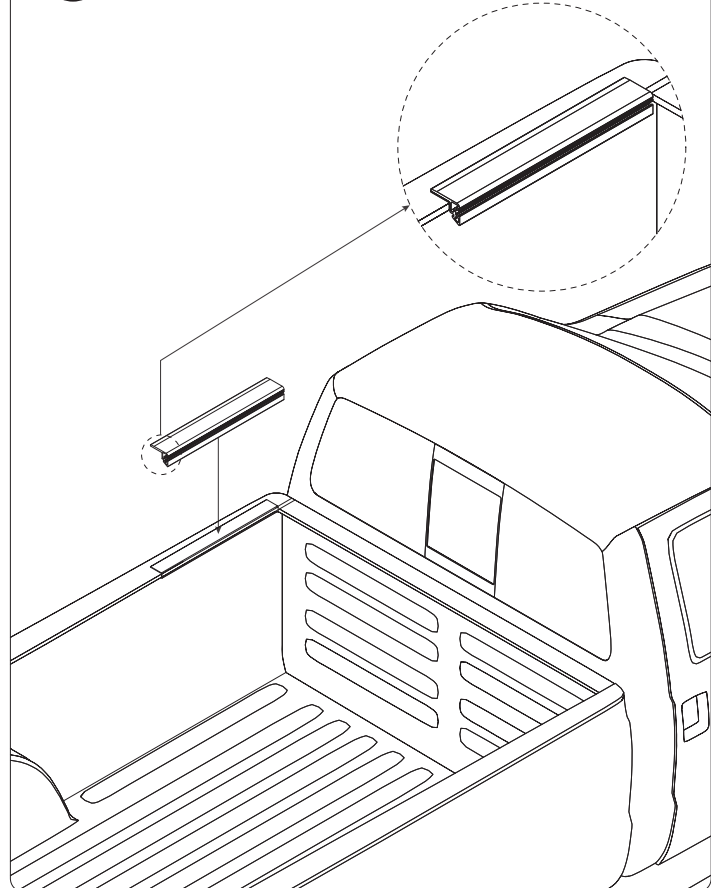

**PCC-0021 RACK ASSEMBLY—FBM ASSEMBLY**

**PRIME DESIGN™**  
A Safe Fleet Brand

**3.1** Set Clamps according to Step 3.2 before sliding onto the PTR Tube Foot.

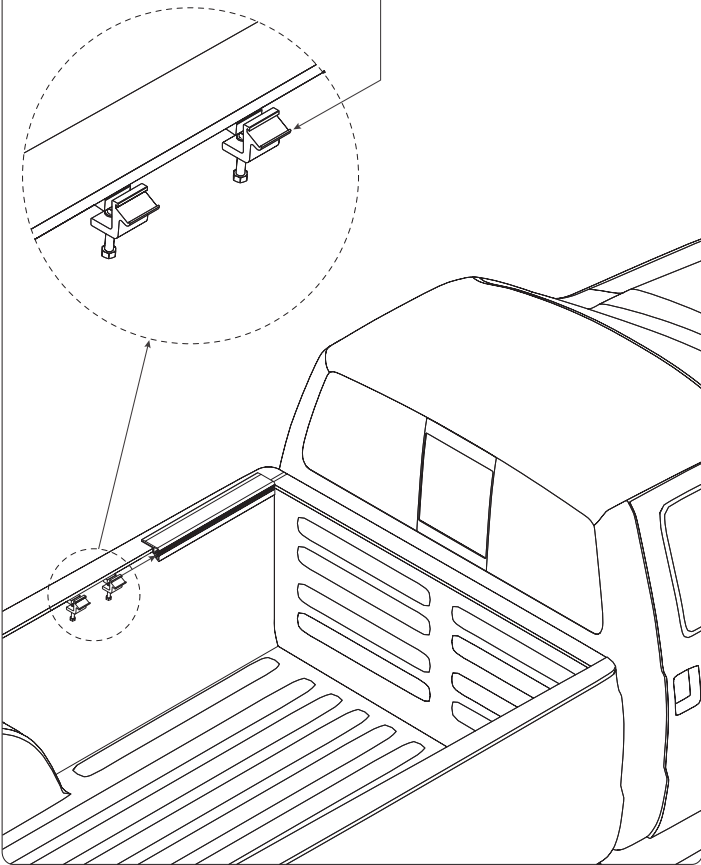

**3.2** Place Truck Clamp Pad on threaded end of the Tube Foot Clamp Bolt. The Truck Clamp Pad has an offset hole. Set Clamp Pad according to Figures A or B.

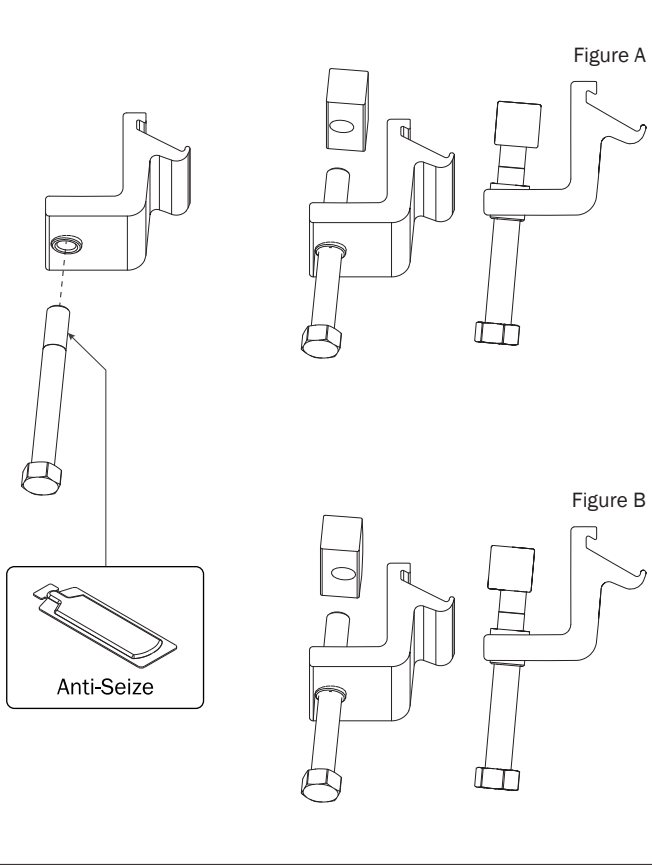

For most applications, the thick side of the Truck Clamp Pad should face inward toward the Tube Foot Clamp as shown in Figure C.

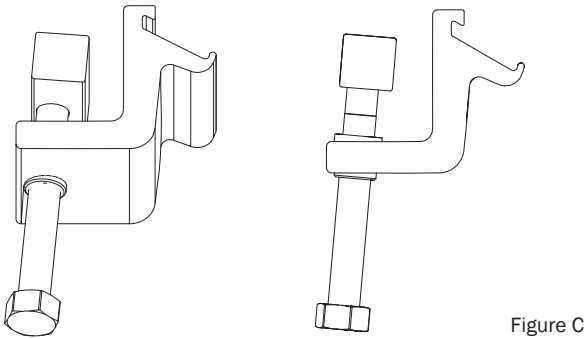

Position the Truck Clamp Pad to Figure D if extra clearance is required for a properly seated installation.

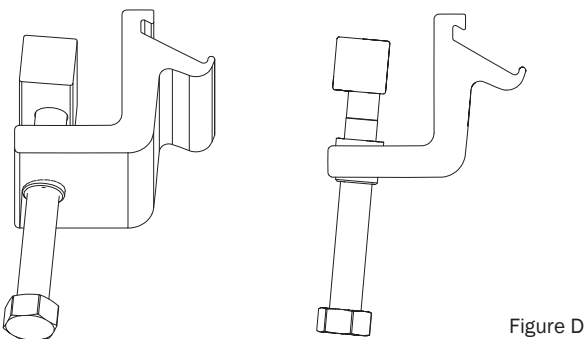

**3.3** Whenever possible, it's preferred to place the Clamps on the thickest metal sections of the bed rail. Place Clamp A as far rearward as possible while still on double wall. Place Clamp B as far forward as possible while still on double wall. Torque Clamp Bolts to 120 in-lbs.

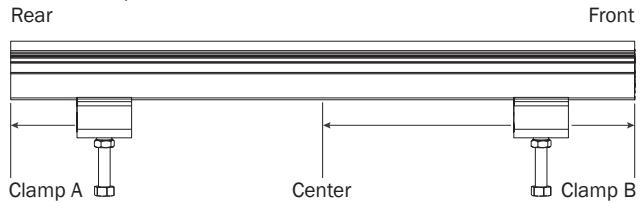

**Note:** Do not position Clamp B rearward of the center of the Tube Foot.

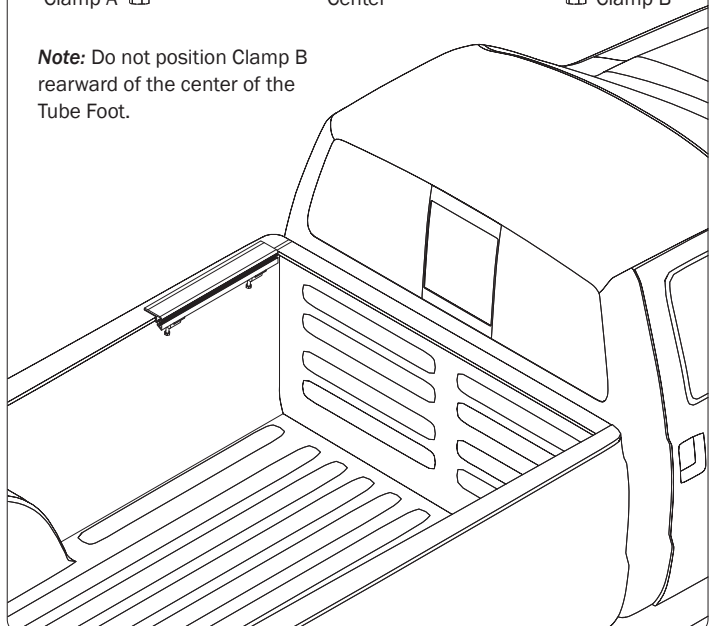

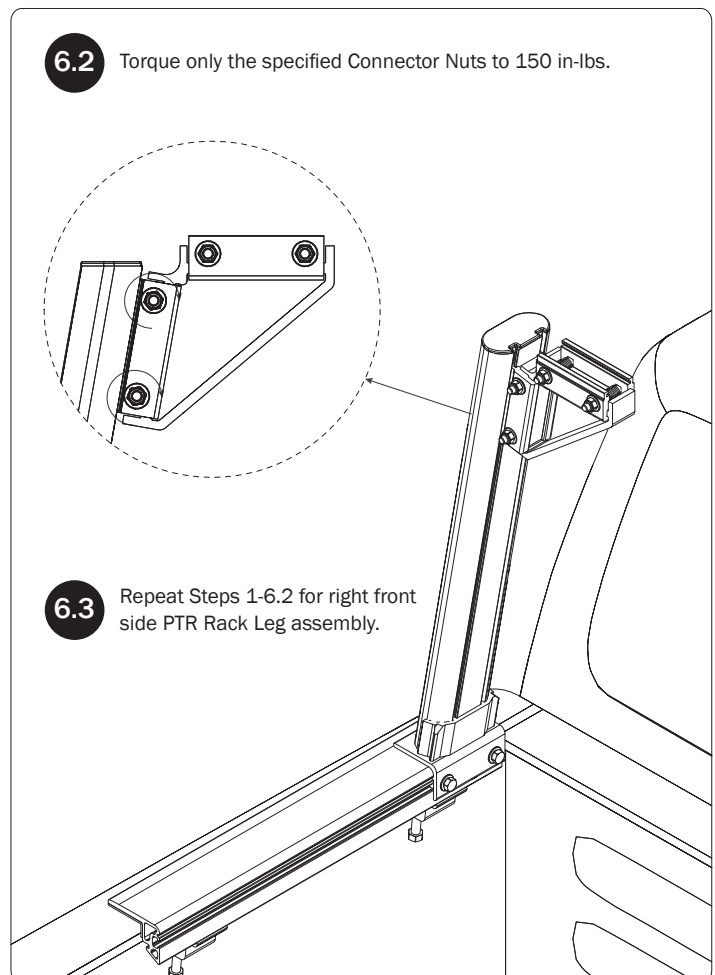
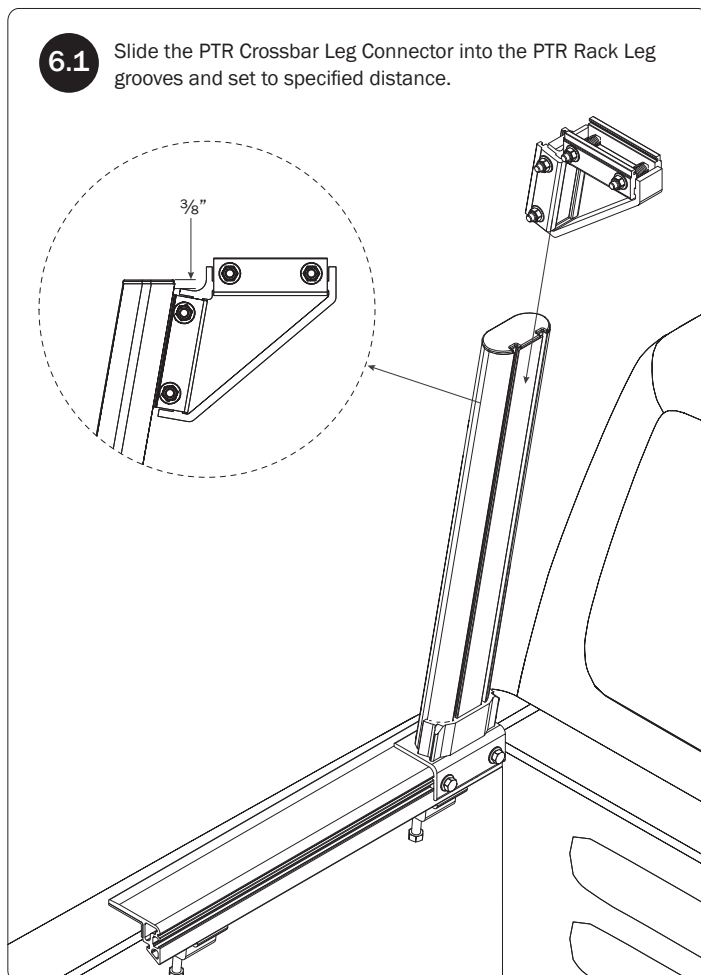
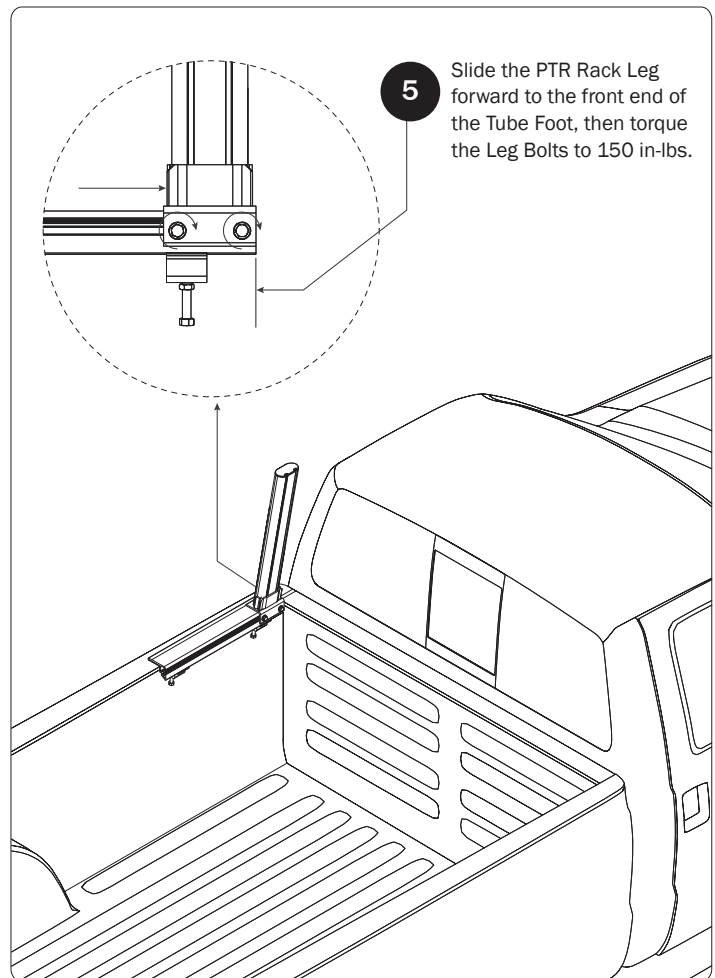
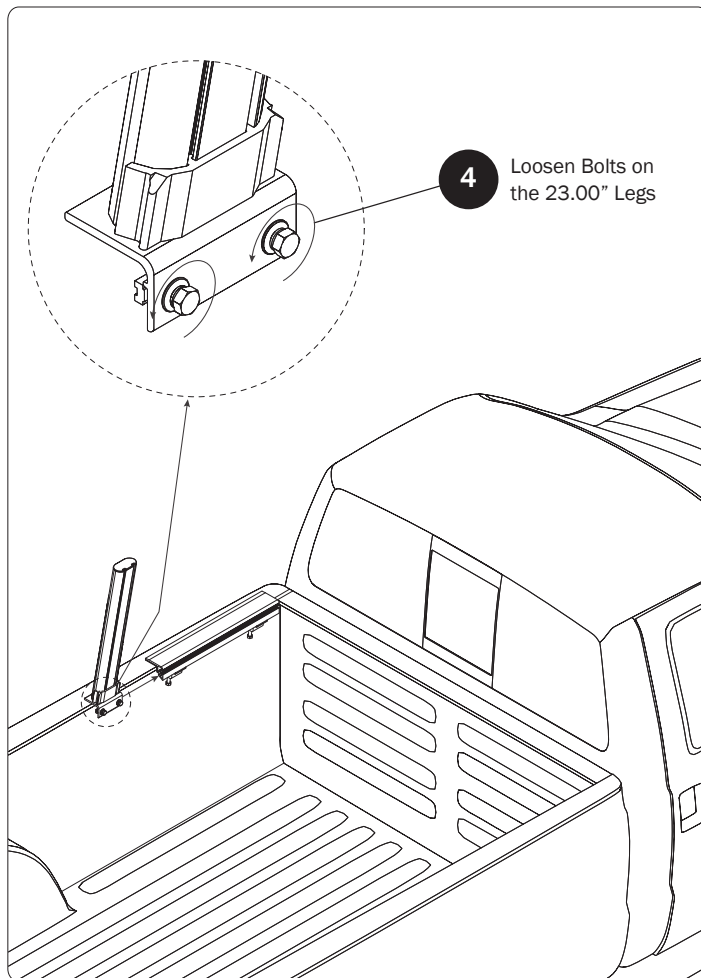

**7.1** Place the Crossbar onto the PTR Rack Leg Connectors.

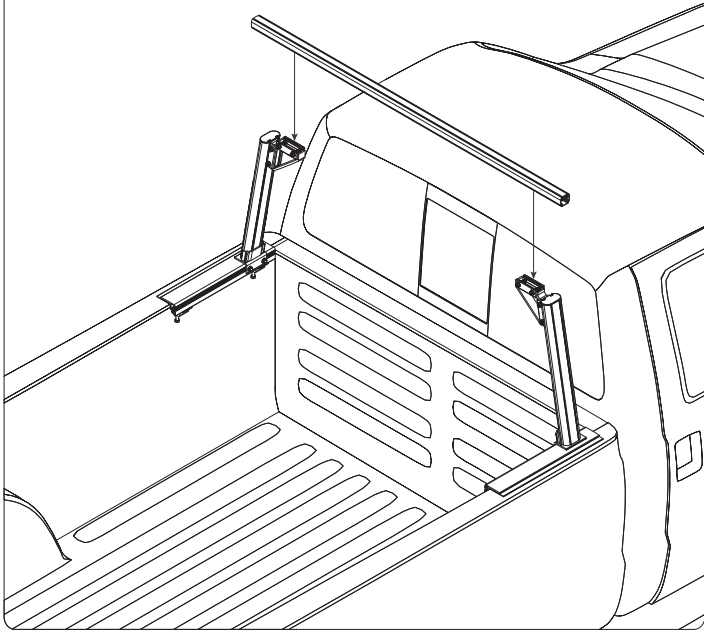

**7.2** Center the Crossbar onto the PTR Rack Legs as shown.

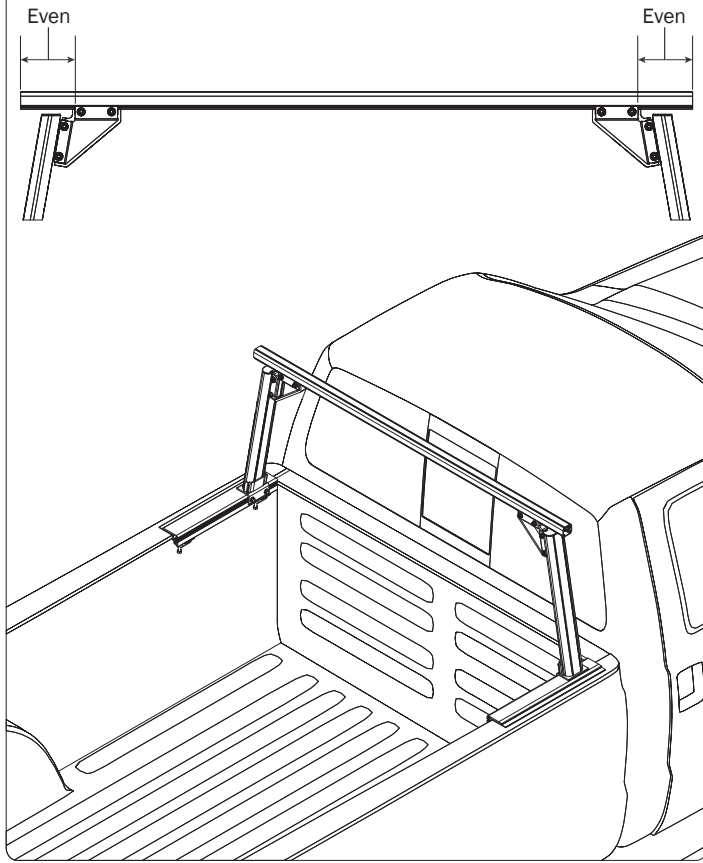

**7.3** Torque nuts to 150 in-lbs.

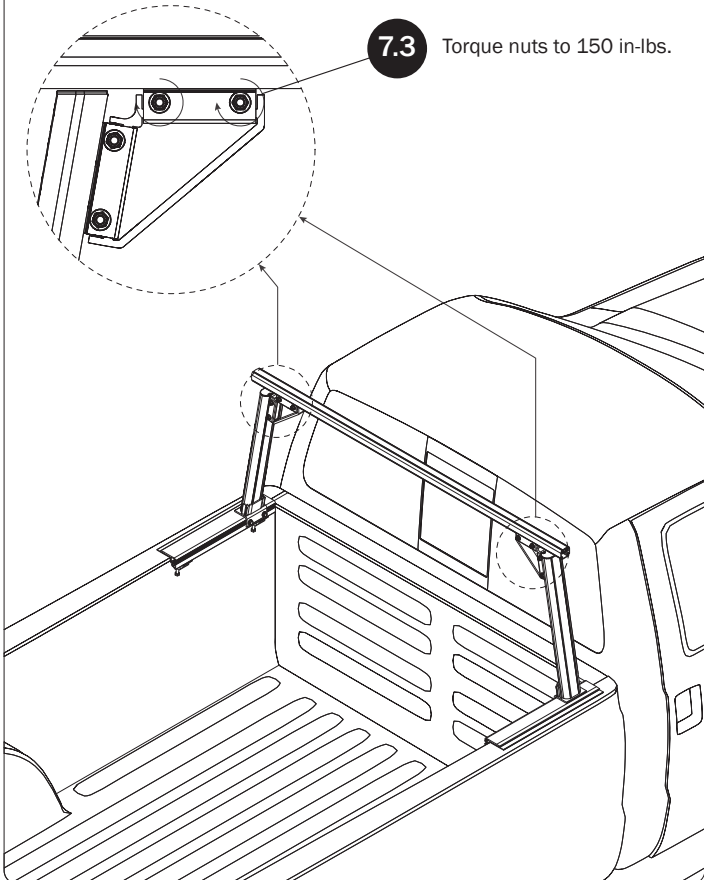

**7.4** Position the Crossbar Brackets onto Crossbar and position as shown. Do not tighten Brackets until Step 16.6. Install the Crossbar End Caps using the supplied screws.

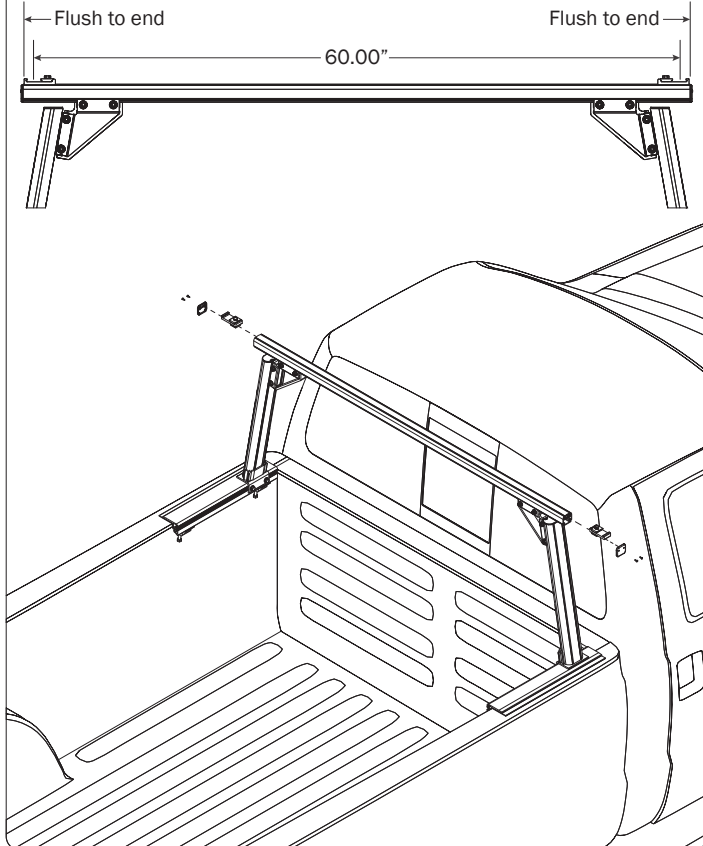

**8** Place the Foot Pad onto the truck's bed rail.

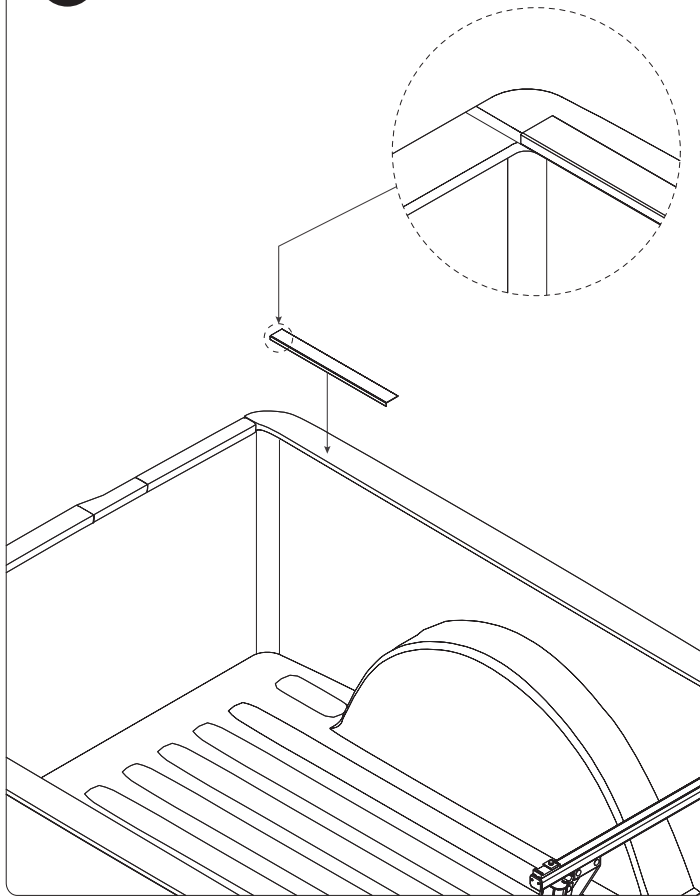

**9** Place the PTR Tube Foot on top of the bed rail Foot Pad.

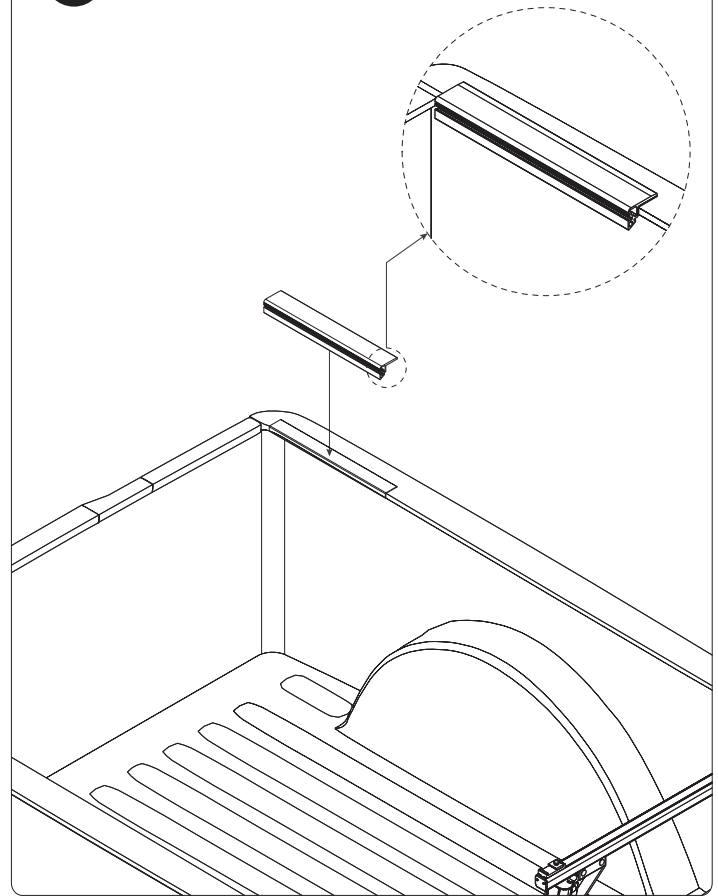

**10.1**

Set Clamps according to Step 10.2 before sliding onto PTR Tube Foot.

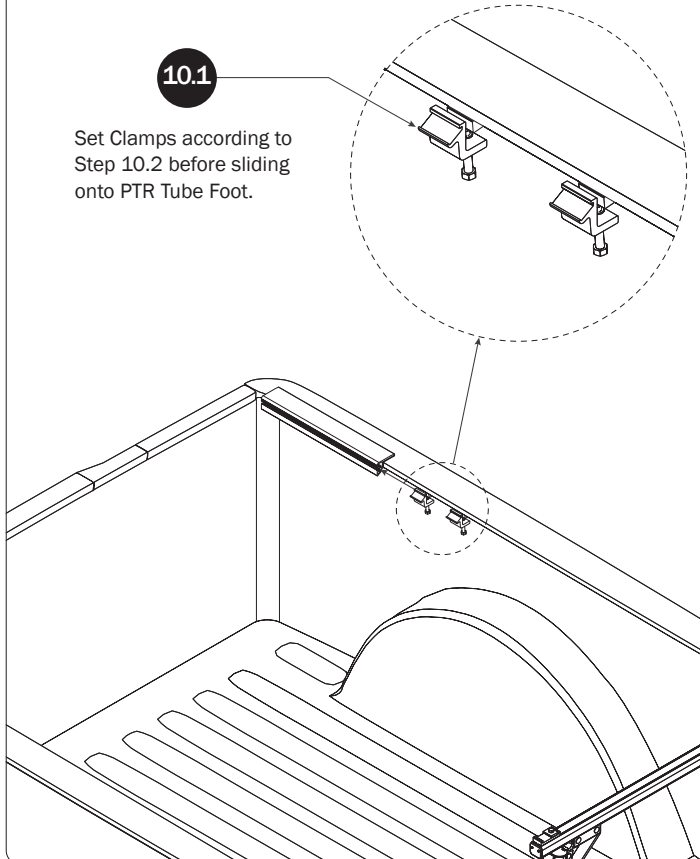

**10.2**

Place Truck Clamp Pad on threaded end of the Tube Foot Clamp Bolt. The Truck Clamp Pad has an offset hole. Set Clamp Pad according to Figures E or F.

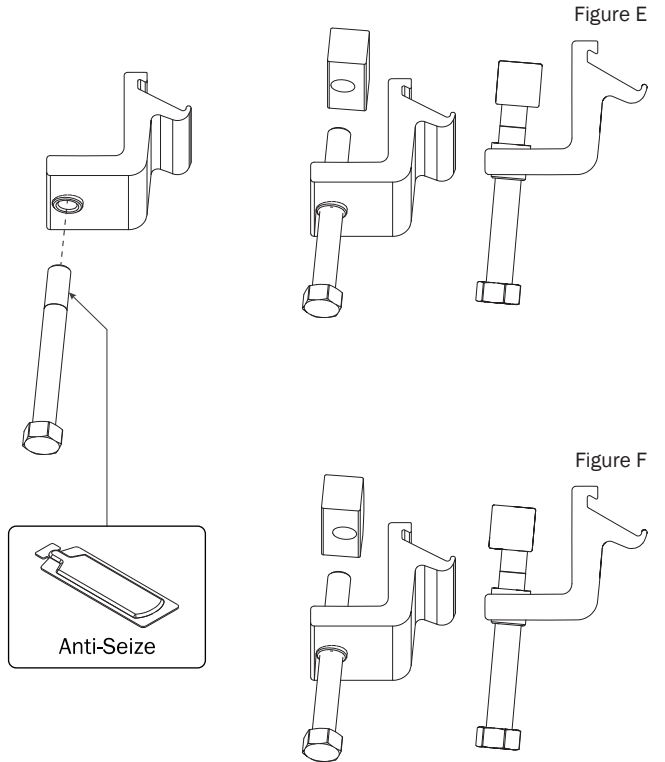



For most applications, the thick side of the Truck Clamp Pad should face inward toward the Tube Foot Clamp as shown in Figure E.

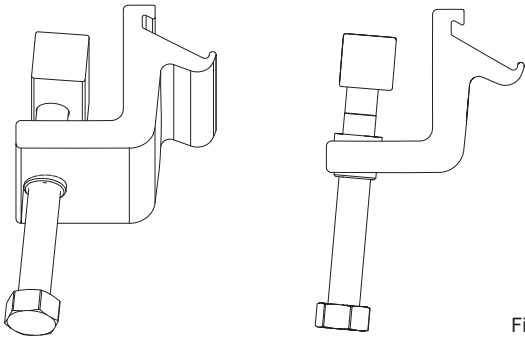

Figure E

Position the Truck Clamp Pad to Figure F if extra clearance is required for a properly seated installation.

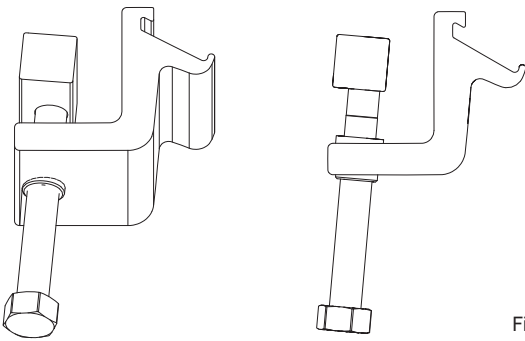
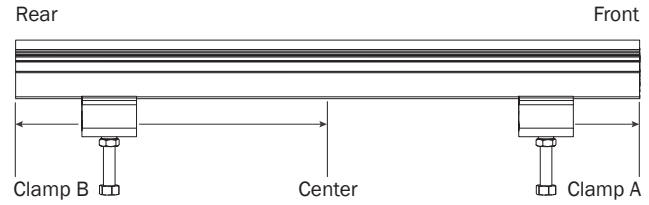

Figure F

10.3

Whenever possible, it's preferred to place the Clamps on the thickest metal sections of the bed rail. Place Clamp A as far forward as possible while still on double wall. Place Clamp B as far rearward as possible while still on double wall. Torque Clamp Bolts to 120 in-lbs.



**Note:** Do not position Clamp B rearward of the center of the Mounting Foot.

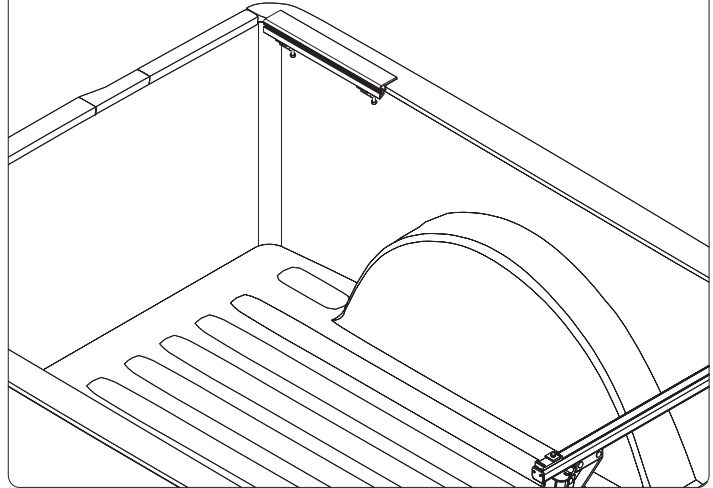

11

Loosen Bolts on the 28.50" Legs

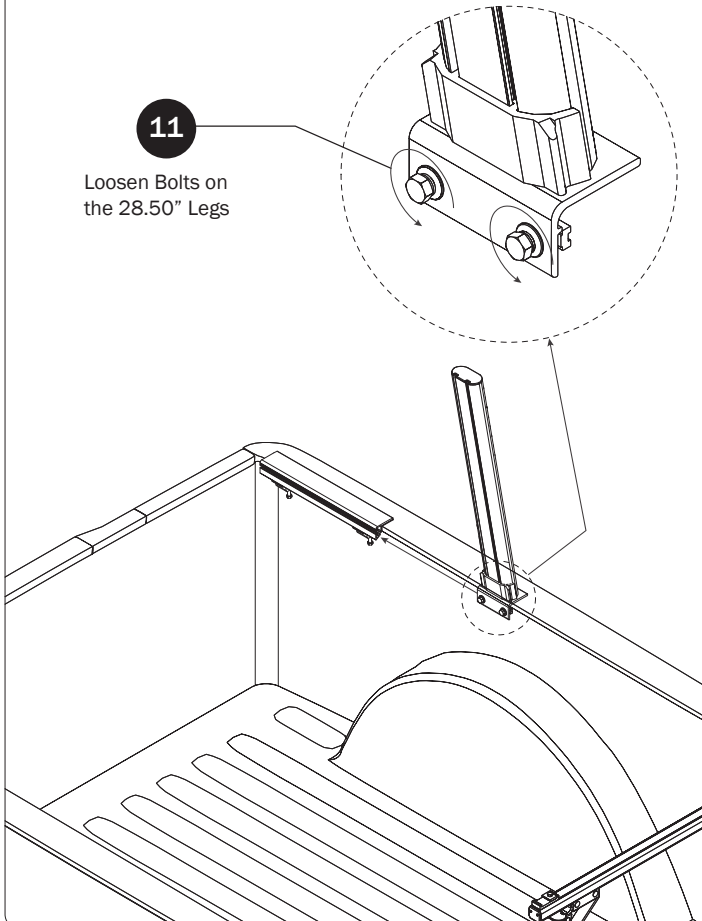

12

Slide the PTR Rack Leg rearward to the back end of the Tube Foot, then torque the Rack Leg Bolts to 150 in-lbs.

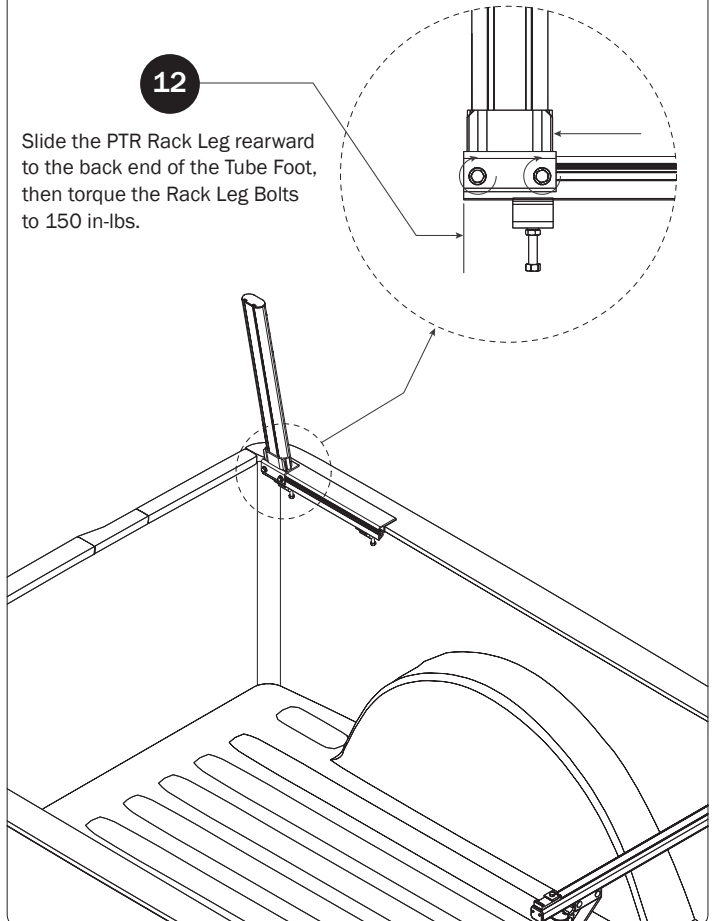

**13.1** Slide the PTR Crossbar Leg Connector into the PTR Rack Leg grooves and set to specified distance.

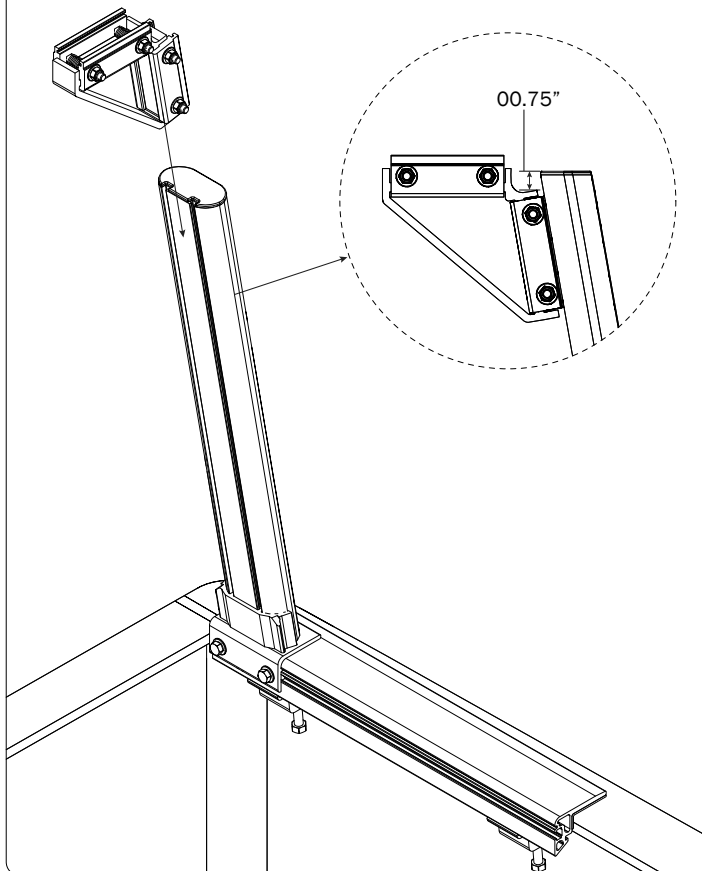

**13.2** Torque only the specified Connector nuts to 150 in-lbs.

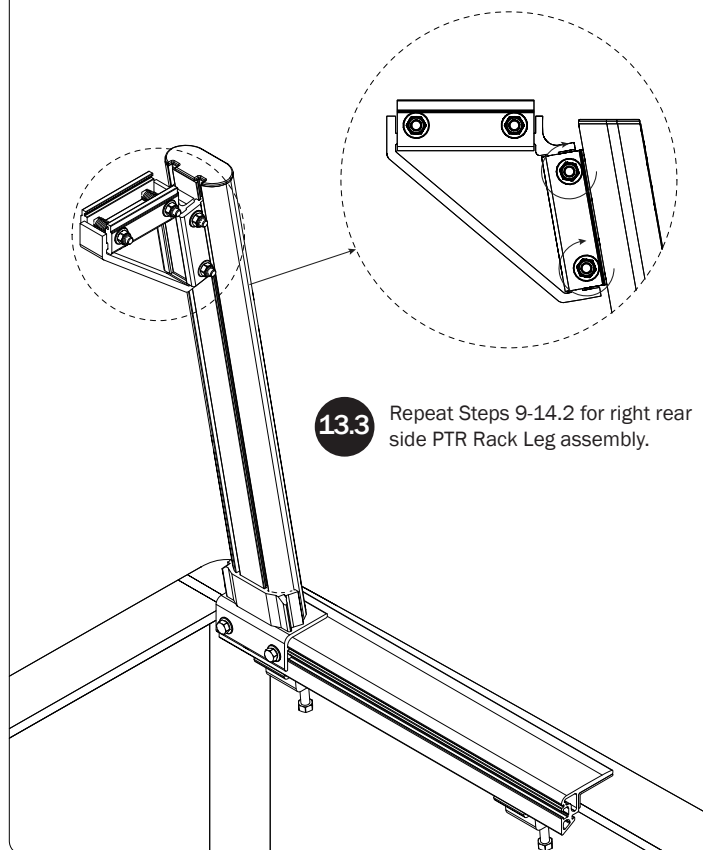

**13.3** Repeat Steps 9-14.2 for right rear side PTR Rack Leg assembly.

**14.1** Loosen the 30MM Hex Head Bolt to allow the Aluminum Strip Nut into the Suspension Bar's upper groove. Loosen the clamp nuts for Crossbar installation on Steps 15.1 and 17.1.

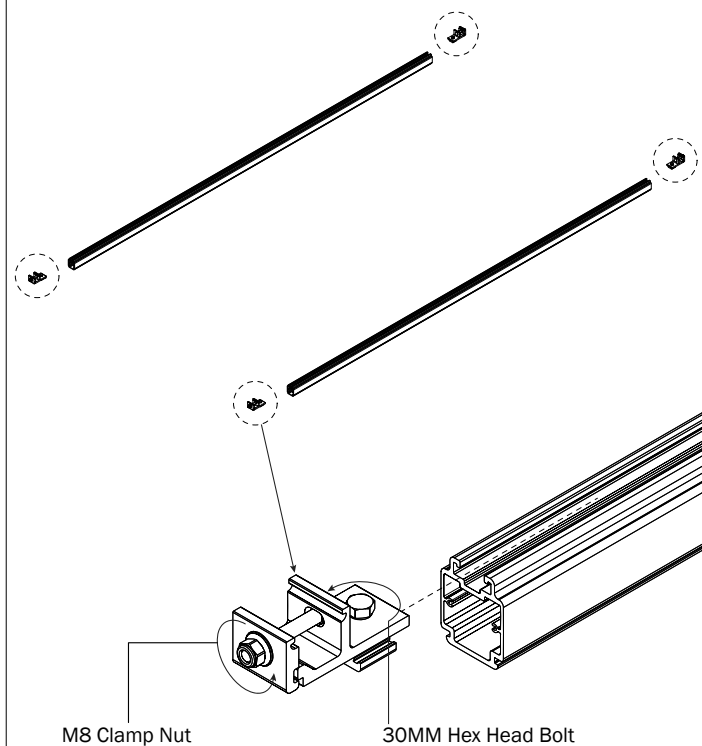

**14.2** Attach the Suspension Bar End Caps using supplied screws.

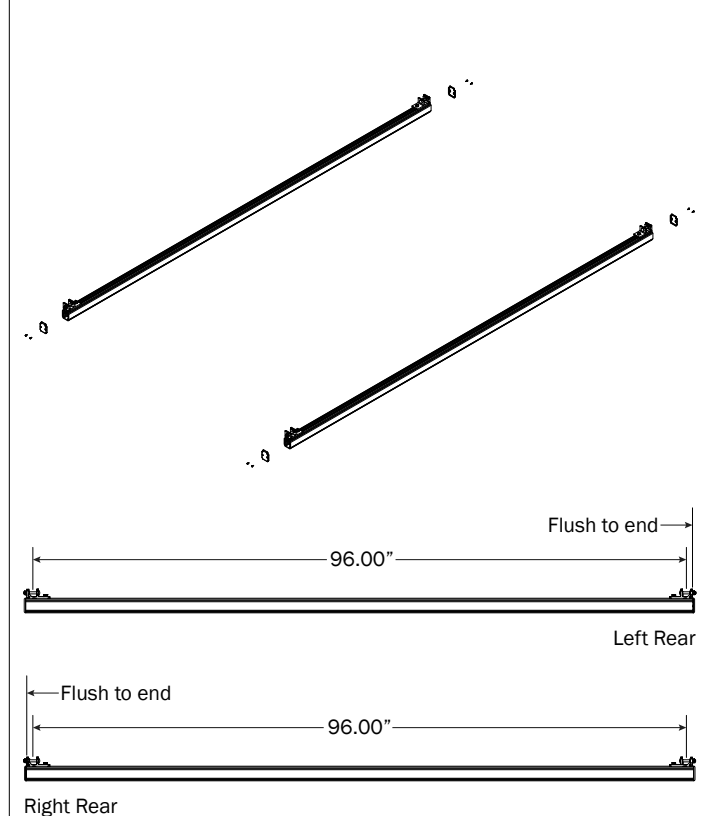

**RIGHT ROTATION  
ASSEMBLY SEQUENCE**

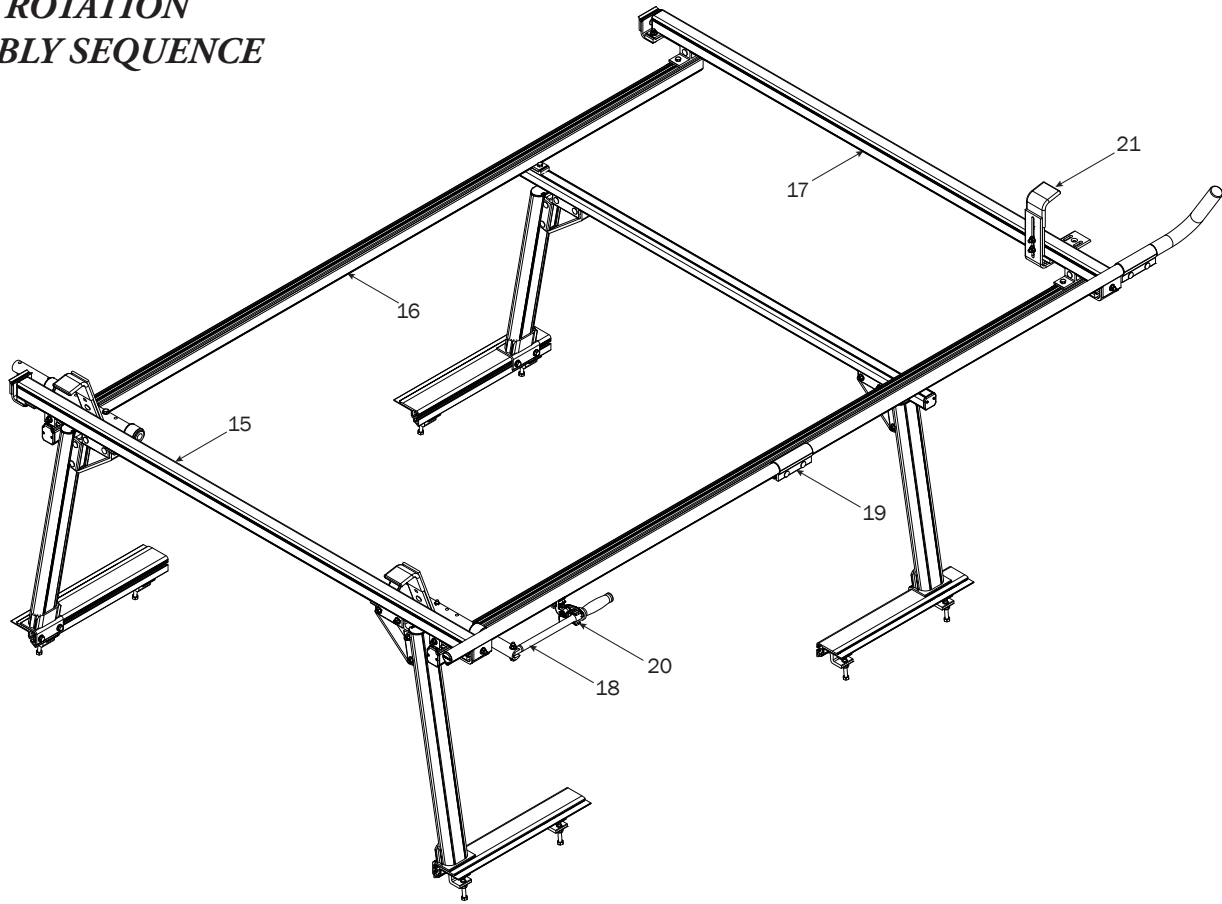

**REAR CROSSBAR**

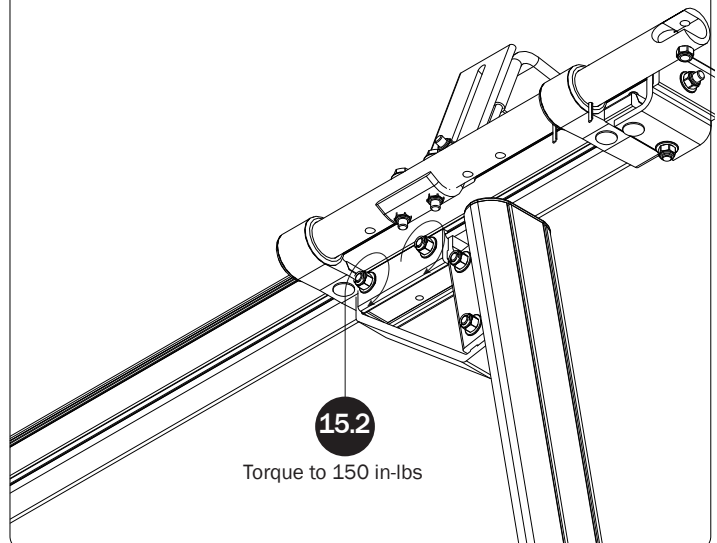
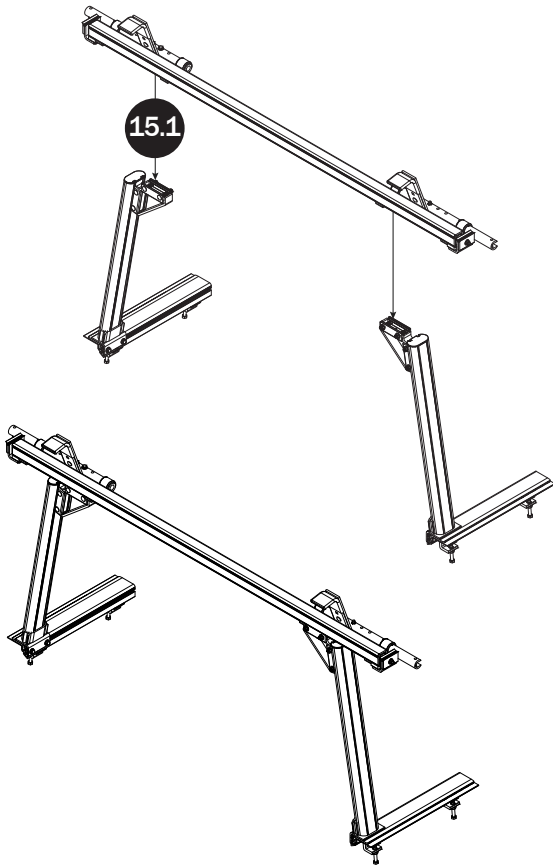

**SUSPENSION BARS**

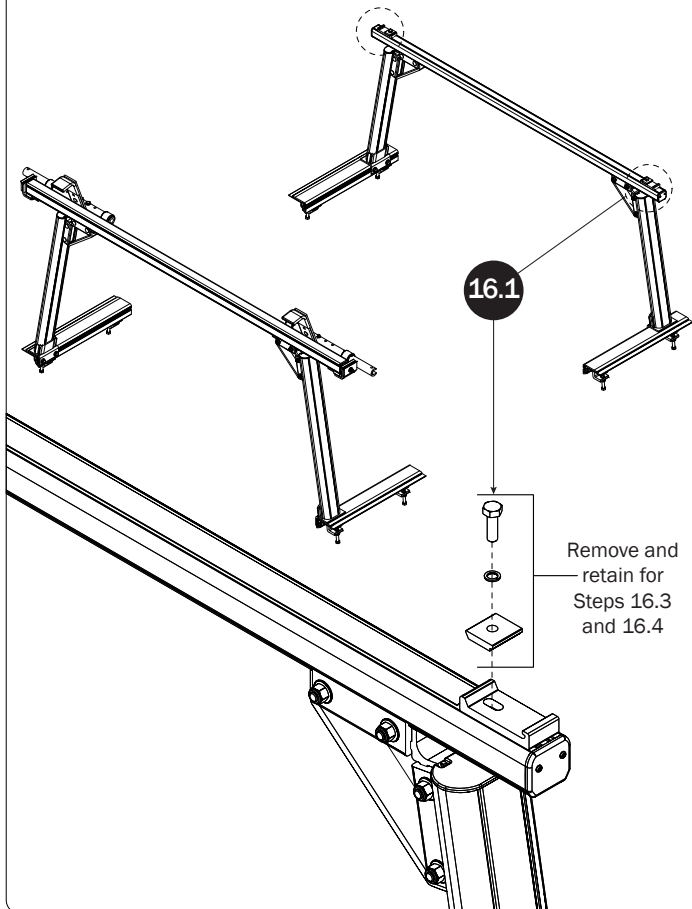

**16.2** Place the Suspension Bars on the Front Crossbar Clamps as shown in Figure H, then attach the rear Suspension Bar Clamps to the bottom of the Rear Crossbar as shown in Figure G.

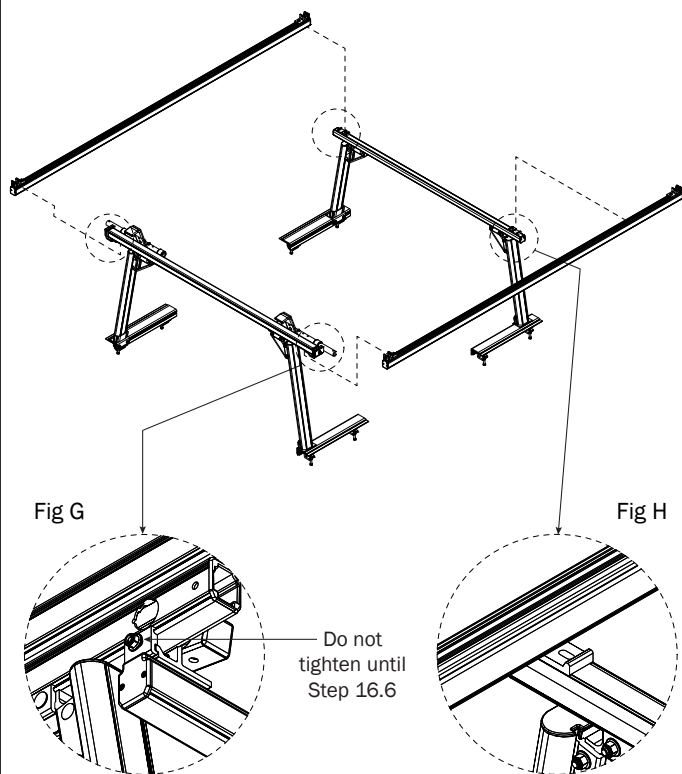

**16.3** Slide the Bracket Clamp into the Crossbar groove and slide onto the Crossbar Mounting Bracket aligning the bolt holes.

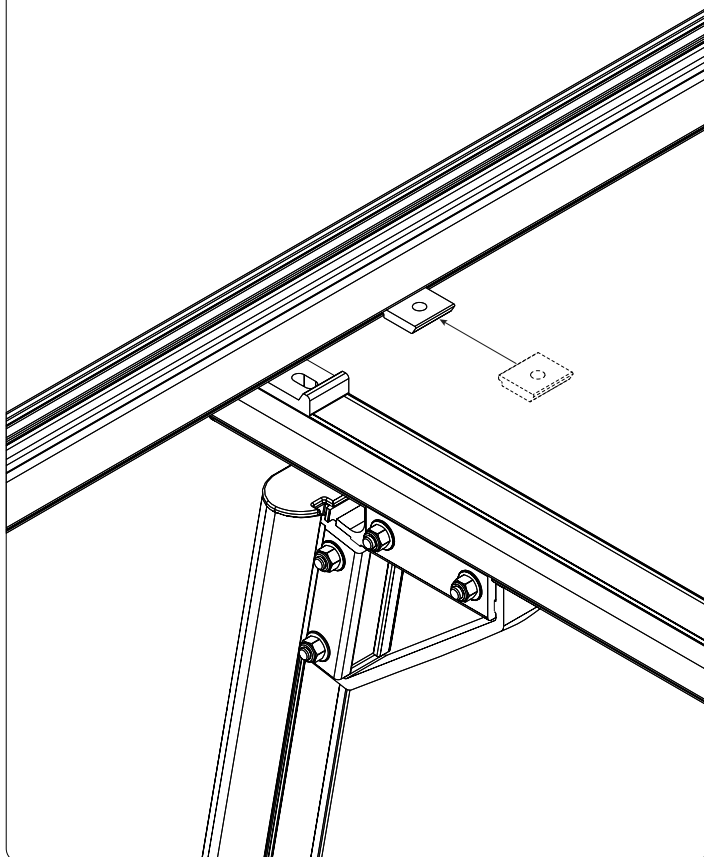

**16.4** Install the Crossbar Mounting Bracket hardware, but do not tighten until Step 16.6.

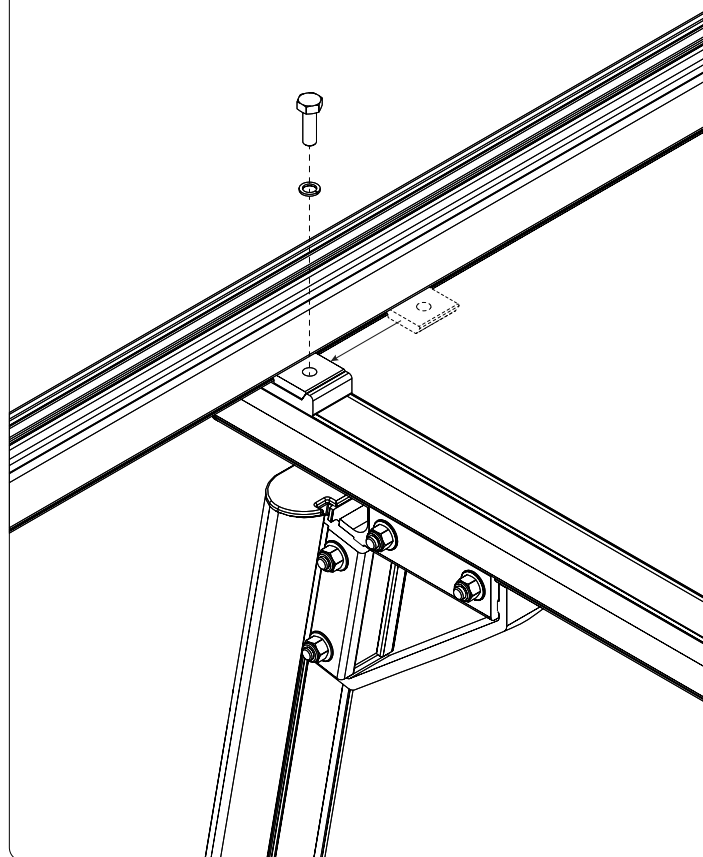

16.5 Adjust Suspension Bar according to Figure I

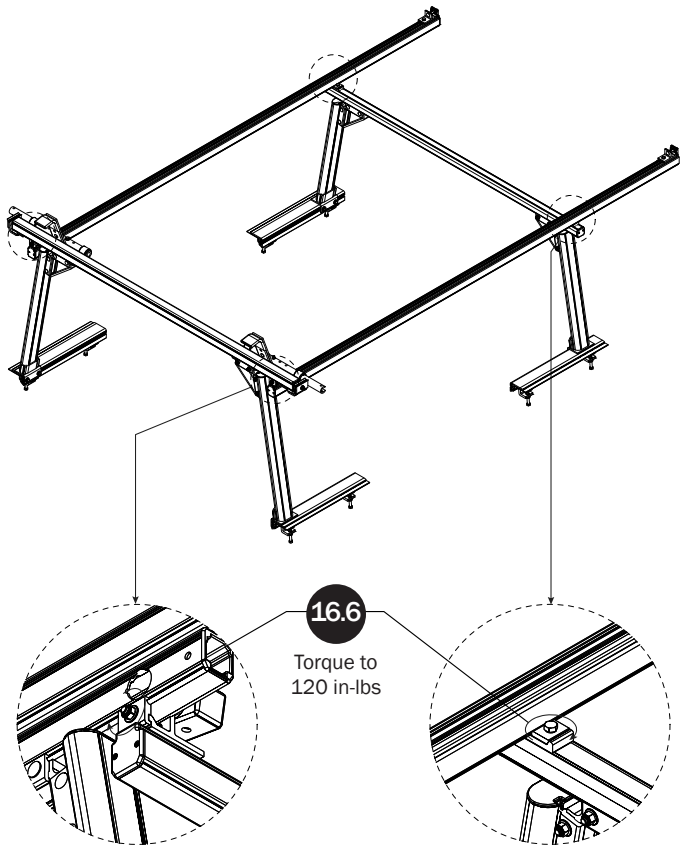
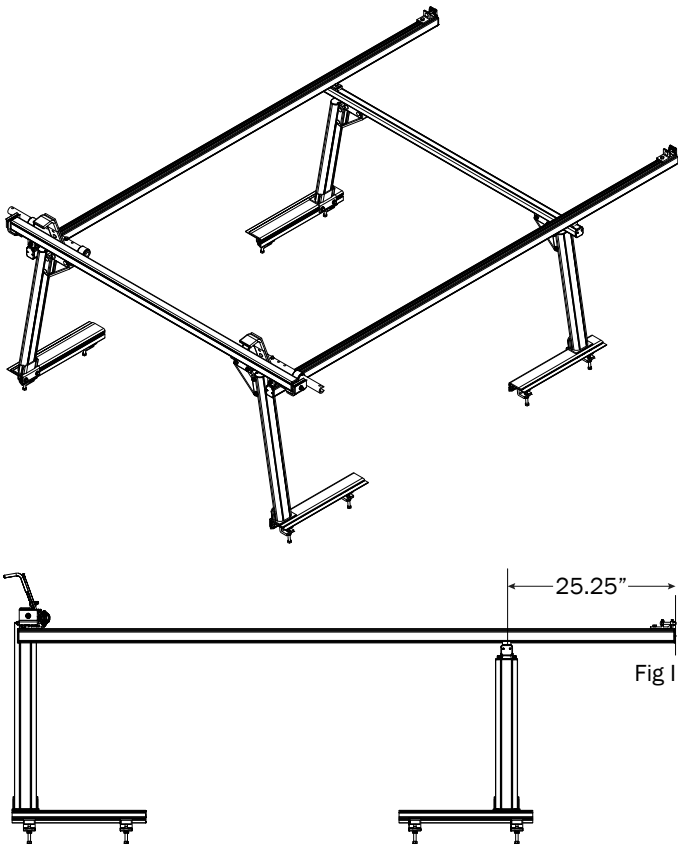

**FRONT CROSSBAR**

17.1

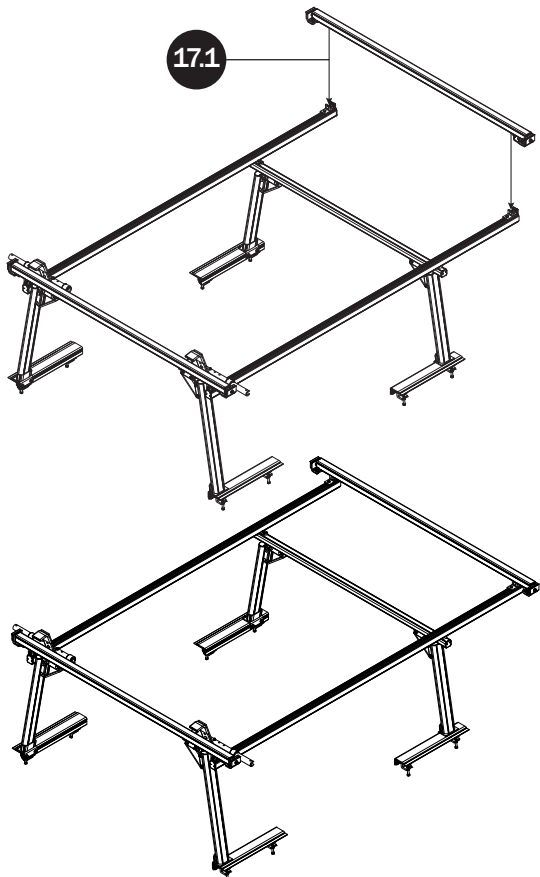

17.2 Adjust Front Crossbar on Suspension Channels as shown.

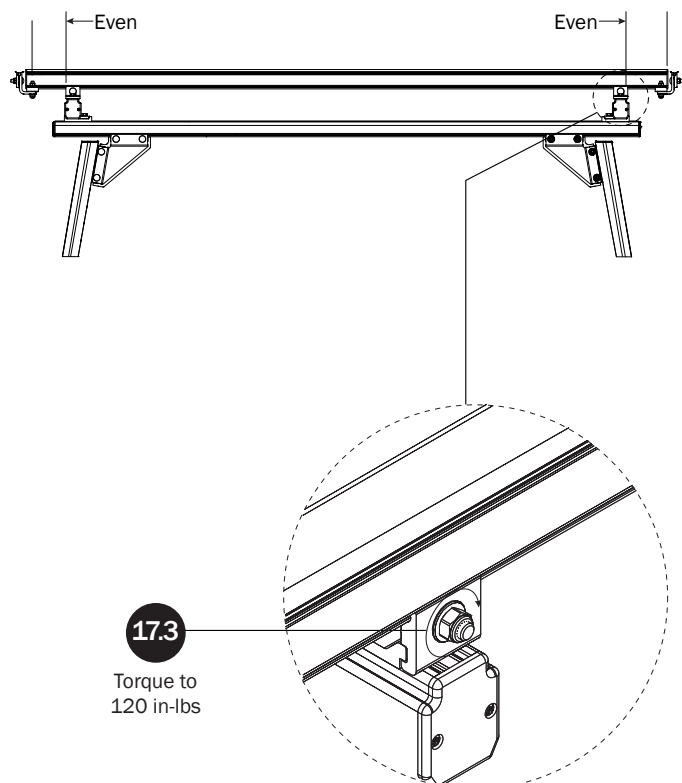

### CLAMP DOWN HANDLE

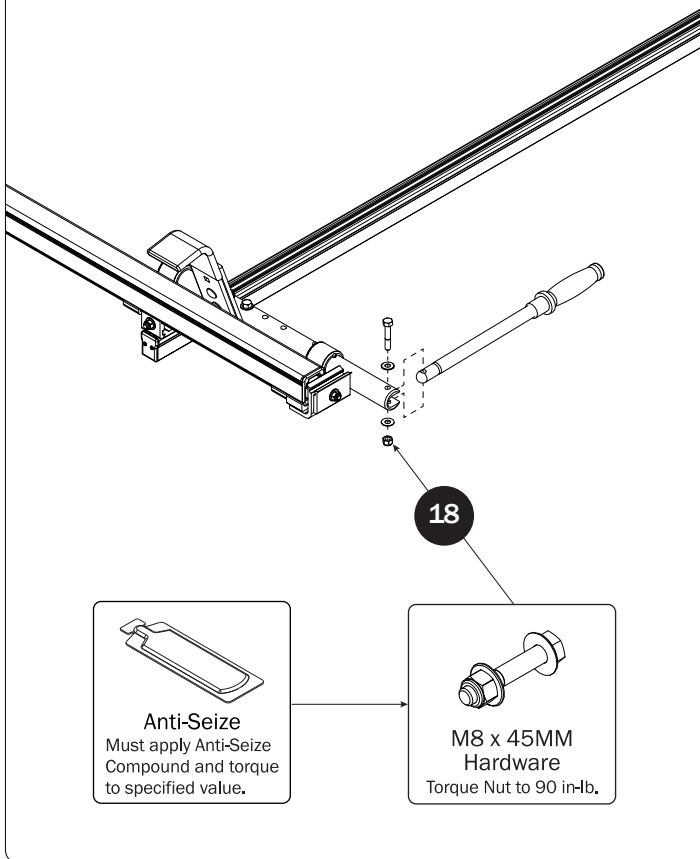

### CLAMP DOWN TUBE

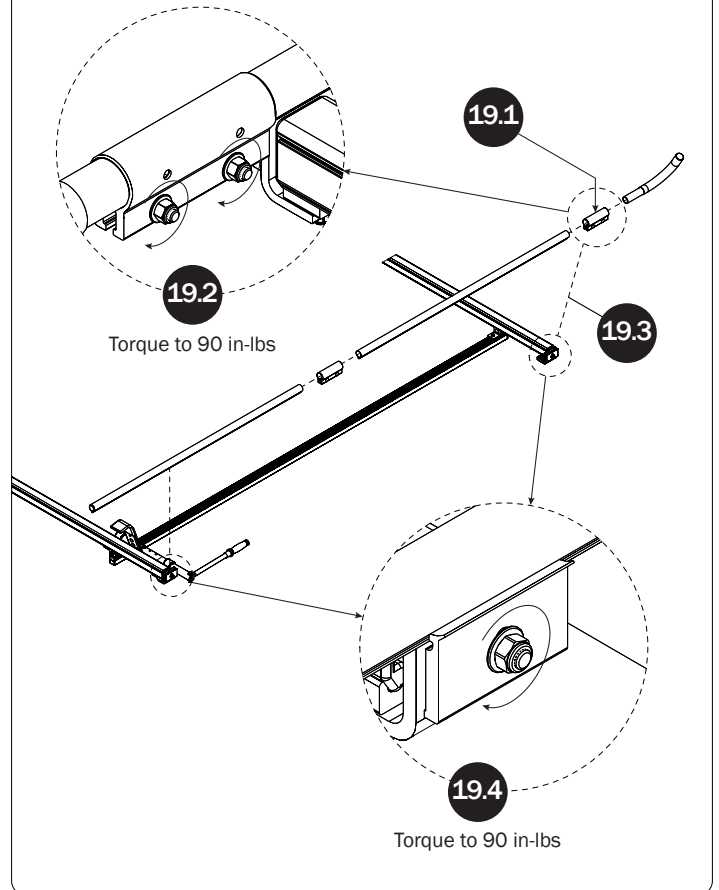

### HANDLE LATCH

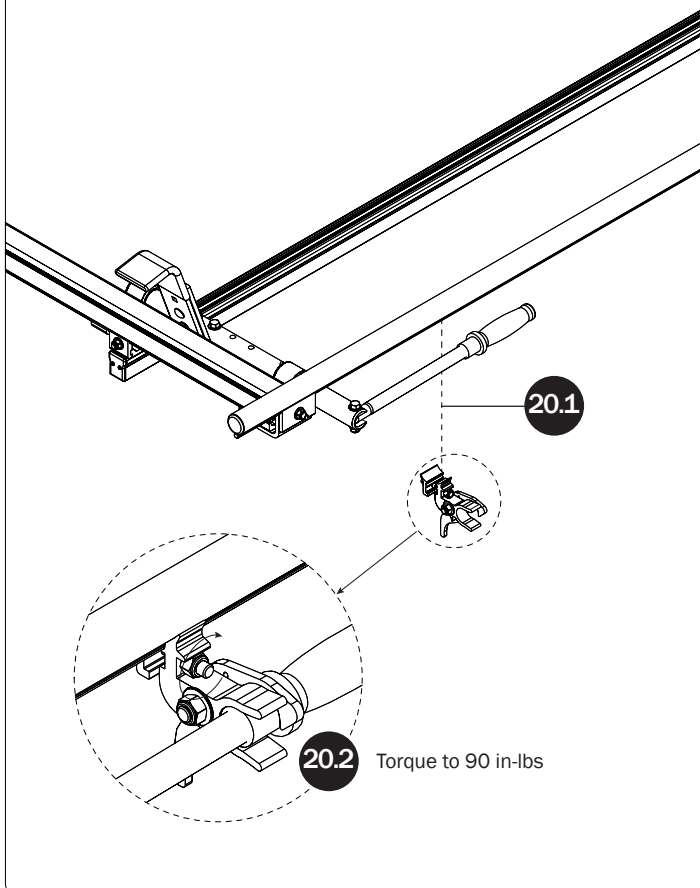

### FRONT LADDER HOOK

SEE QUICK START GUIDE FOR ADJUSTMENTS

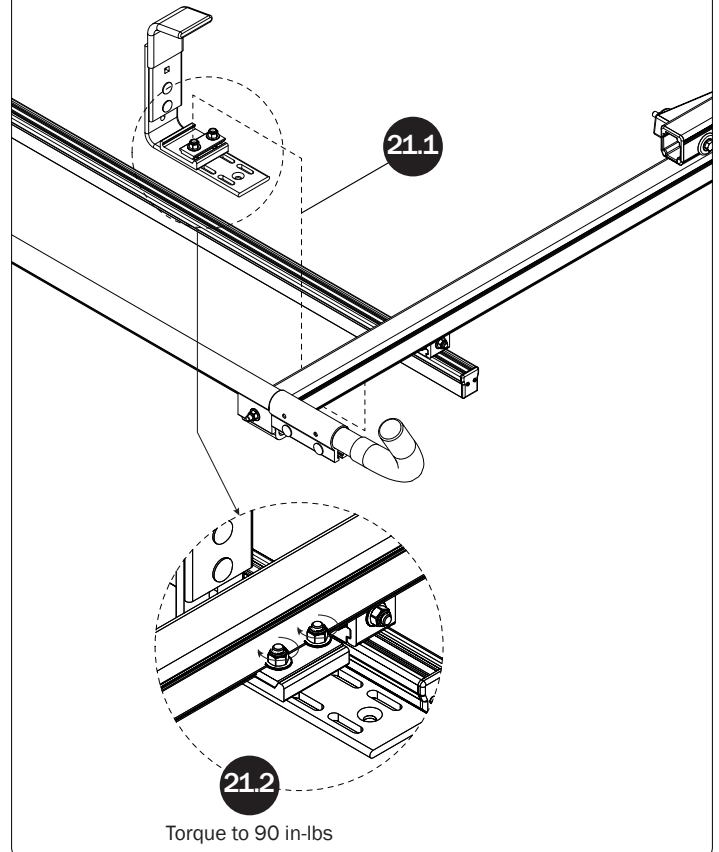

**LEFT CLAMP DOWN  
ASSEMBLY SEQUENCE**

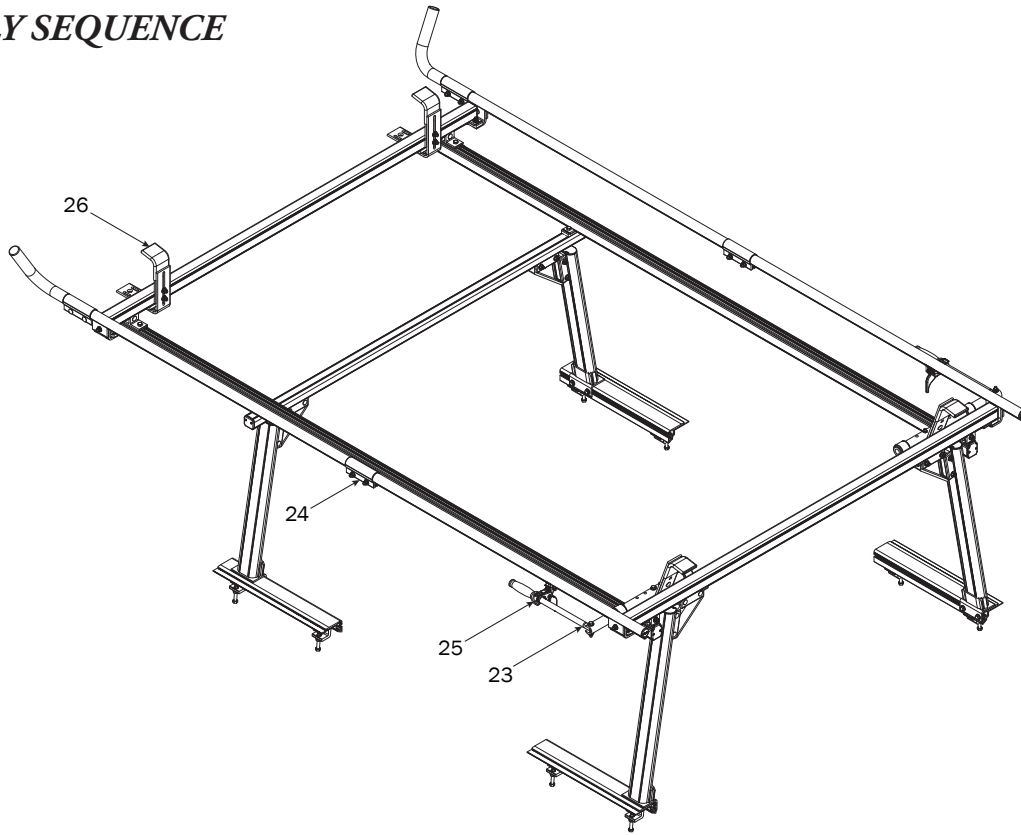

**CLAMP DOWN HANDLE**

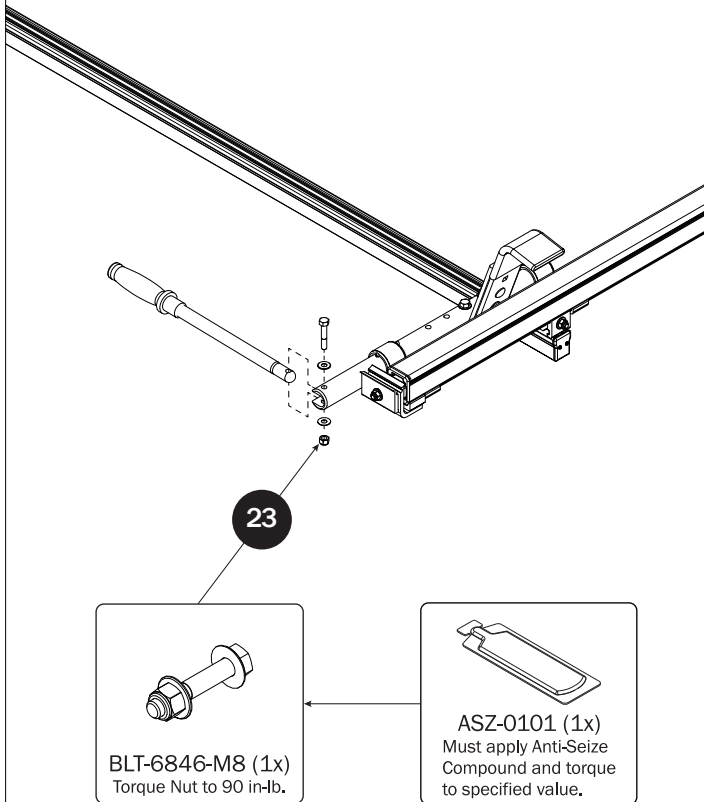

**CLAMP DOWN TUBE**

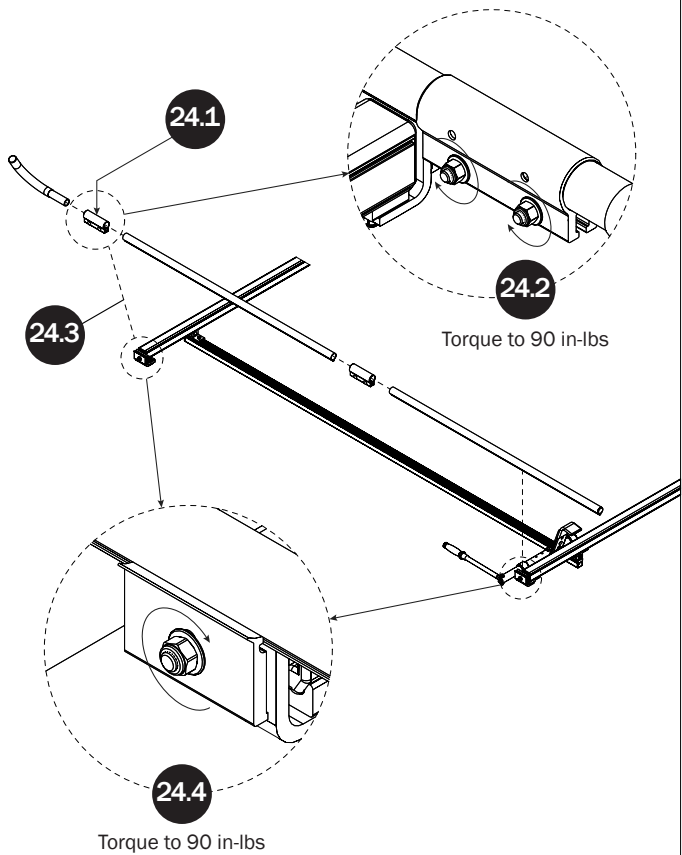

**HANDLE LATCH**

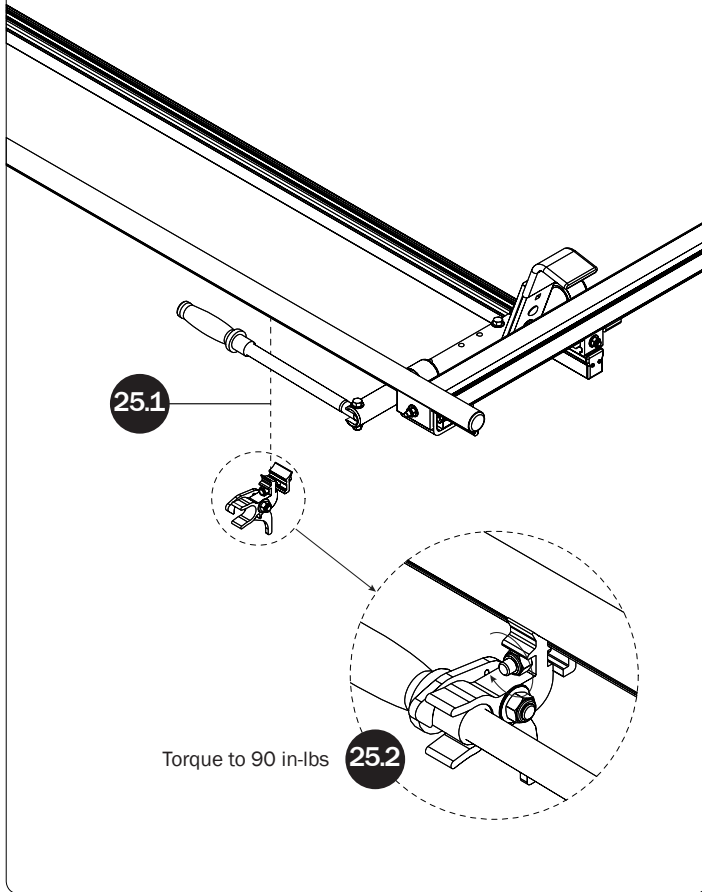

**FRONT LADDER HOOK**

SEE QUICK START GUIDE FOR ADJUSTMENTS

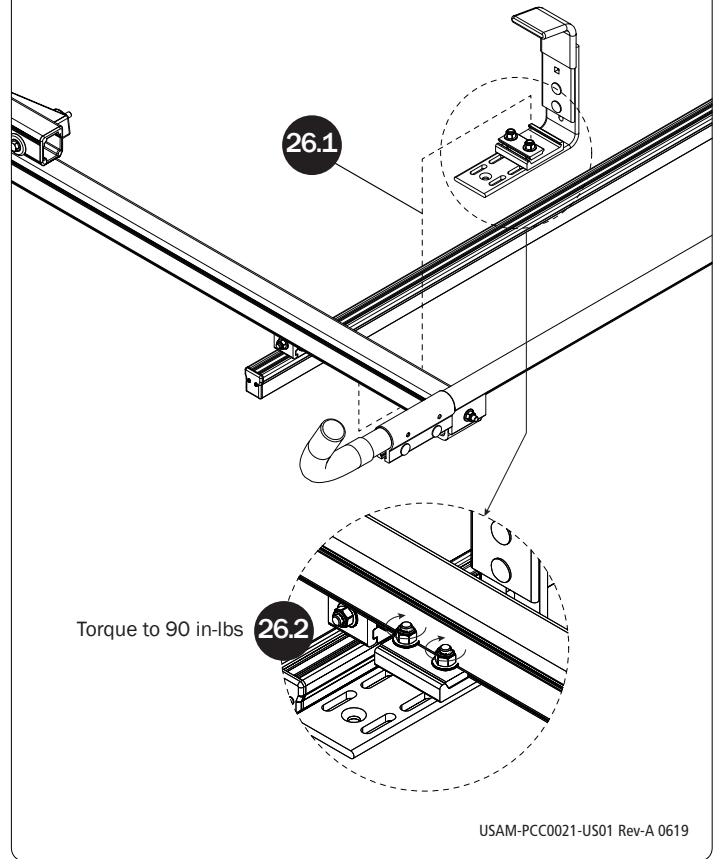

USAM-PCC0021-US01 Rev-A 0619