

PRIME DESIGN™

A Safe Fleet Brand

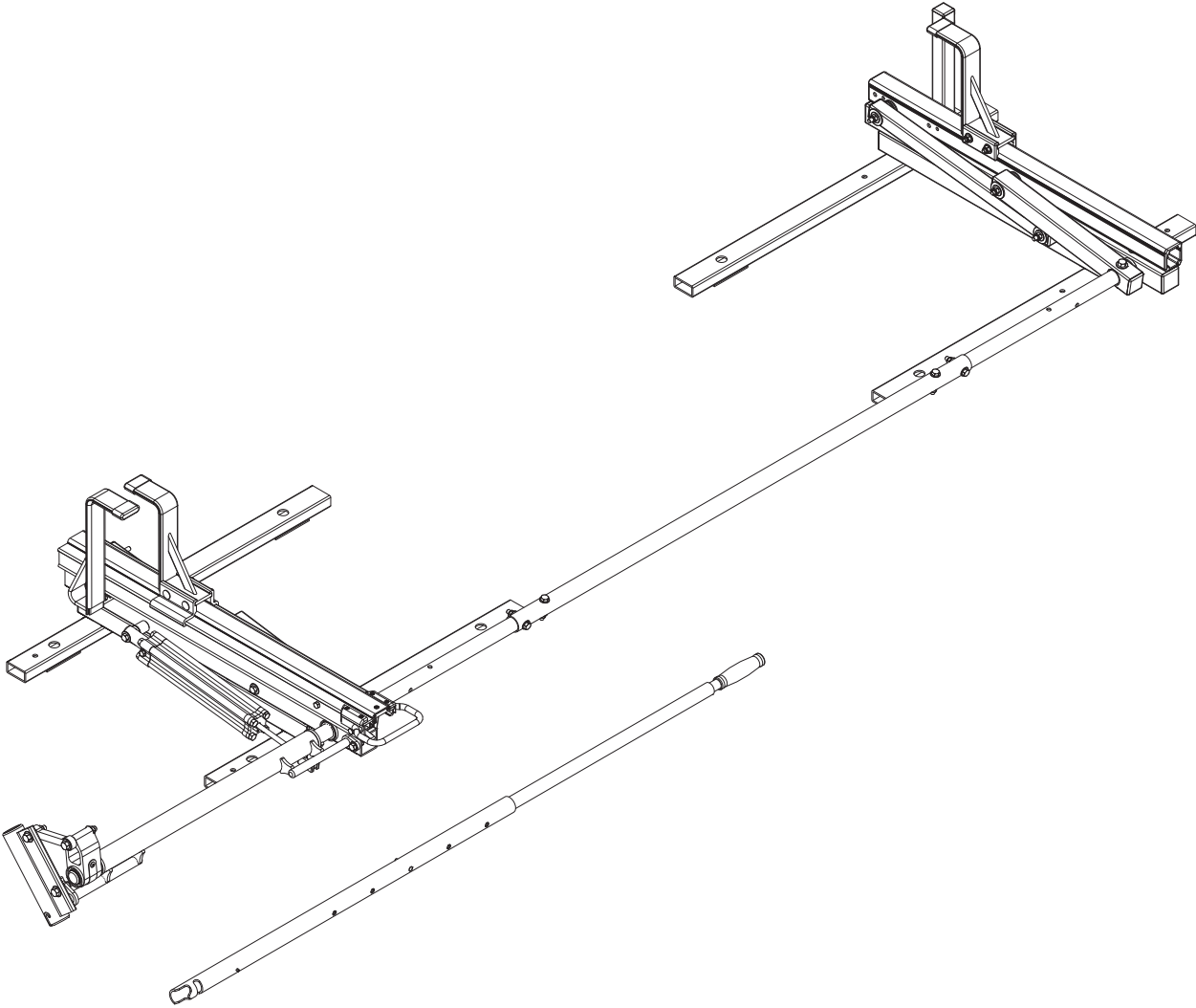

HXR
009-F

CONTENTS OVERVIEW

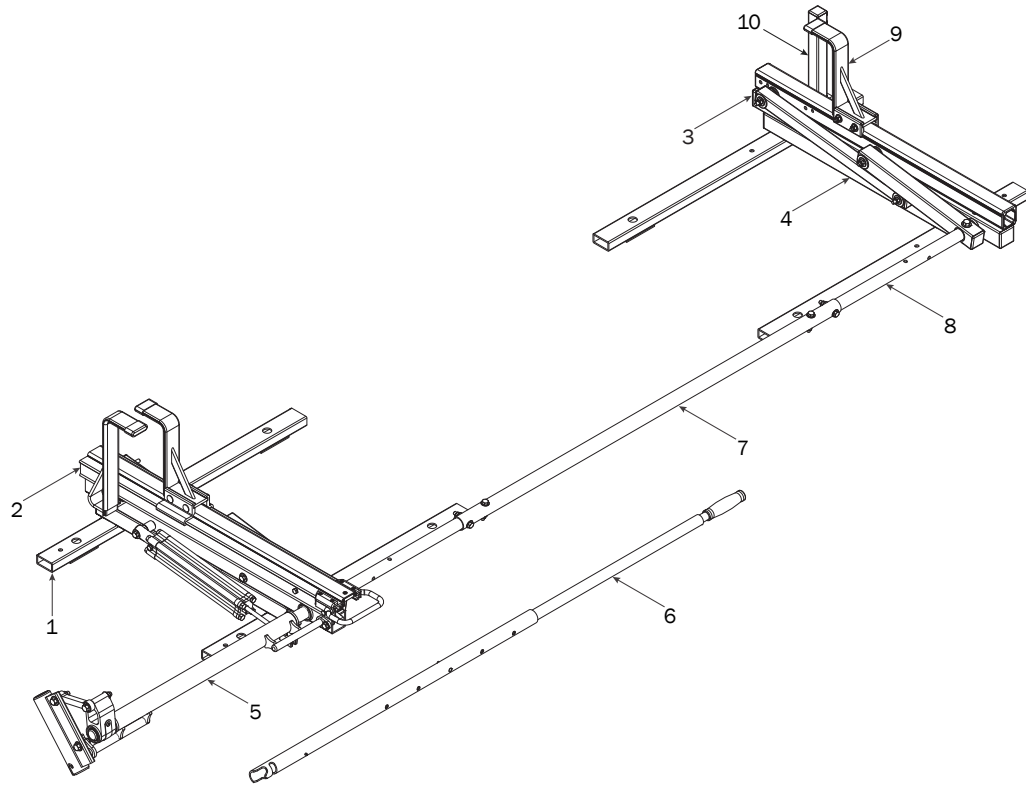

1—Mounting Base Assembly (Qty 4)
Mounting w/Hardware Kit

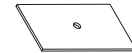

Foam Pad (2X)

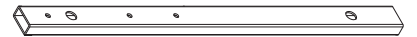

Mounting Base (1X)

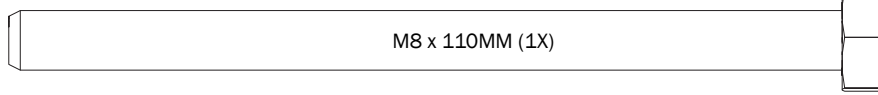

M8 x 110MM (1X)

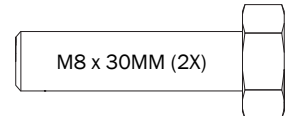

M8 x 30MM (2X)

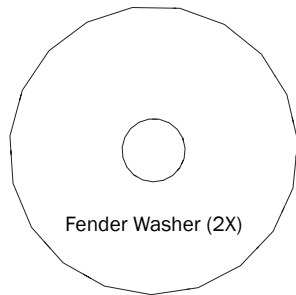

Fender Washer (2X)

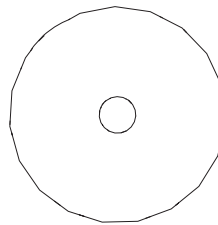

Neoprene Washer (2X)

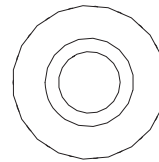

Sealing Washer (2X)

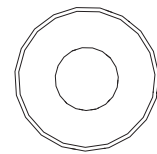

Flat Washer (2X)

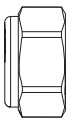

Lock Nut (3X)

2—Rear Crossbar Assembly (Qty 1)

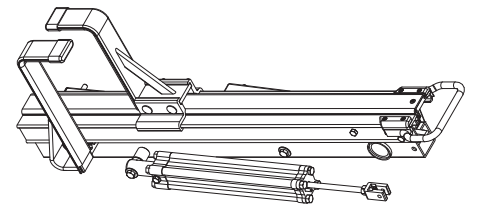

3—Front Crossbar Assembly (Qty 1)

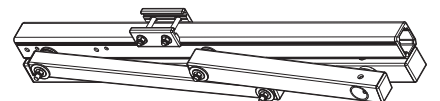

4—Canopy Top Base (Qty 2)
24.00"

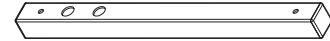

5—Rear Drive Shaft (Qty 1)
Right Hand, A Version, 50.00"

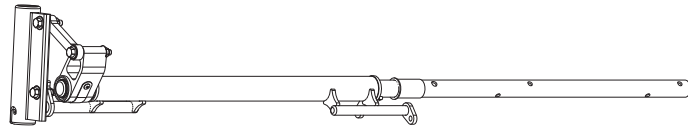

6—HHR Handle Assembly (Qty 1)
35.00"

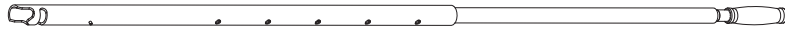

7—Connecting Bar (Qty 1)
4.00'

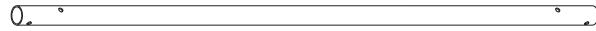

8—Front Drive Shaft (Qty 1)
B Version, 35.75"

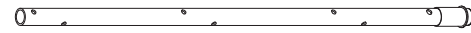

9—Z Post (Qty 1)
Adjustment, 7.25"

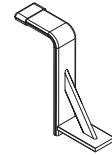

10—L Post (Qty 1)
9.25", Gen1

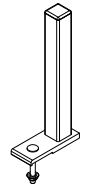

11—HKT-8163 (Not called out in Overview) (Qty 1)

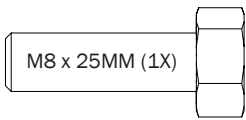

M8 x 25MM (1X)

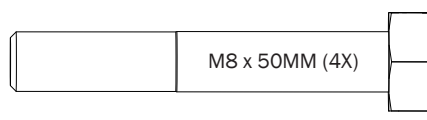

M8 x 50MM (4X)

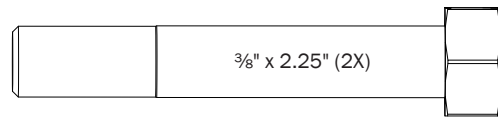

3/8" x 2.25" (2X)



Cotter Pin (1X)

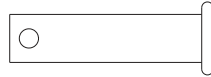

Clevis Pin (1X)

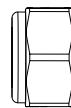

M8 Lock Nut (5X)



3/8" Lock Nut (2X)

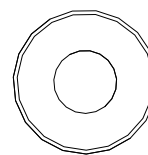

5/16" Flat Washer (10X)

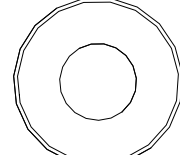

3/8" Flat Washer (4X)

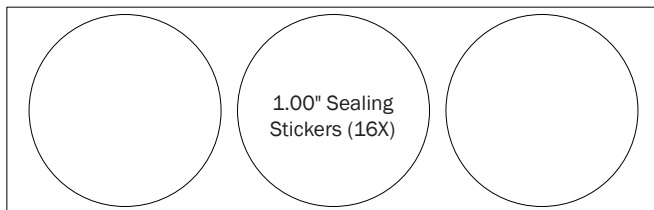

1.00" Sealing Stickers (16X)



Anti-Seize (2X)

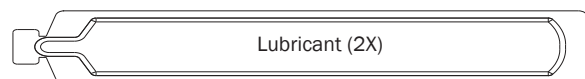

Lubricant (2X)

MOUNTING DIMENSIONS

0.1 6.00 Ft: Drill holes into the service body mounting location according to dimensions shown.

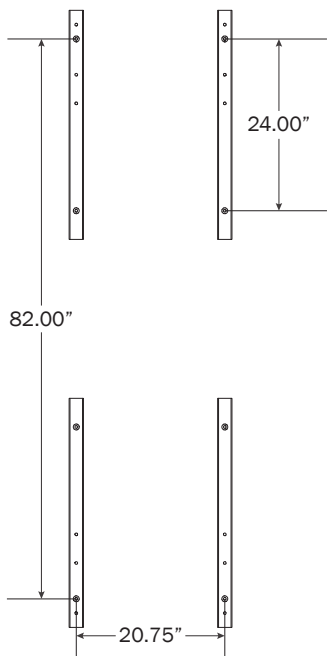

0.2 7.00 Ft: Drill holes into the service body mounting location according to dimensions shown.

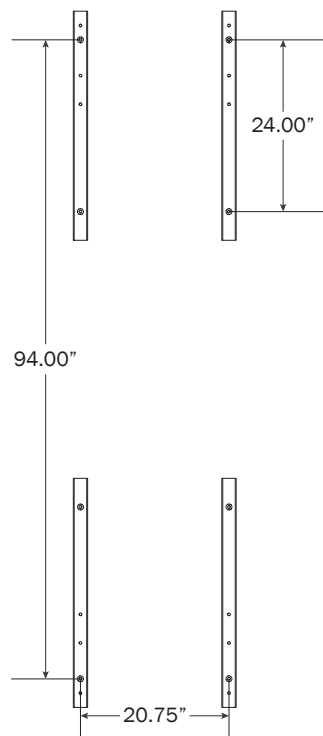

0.3 8.00 Ft: Drill holes into the service body mounting location according to dimensions shown.

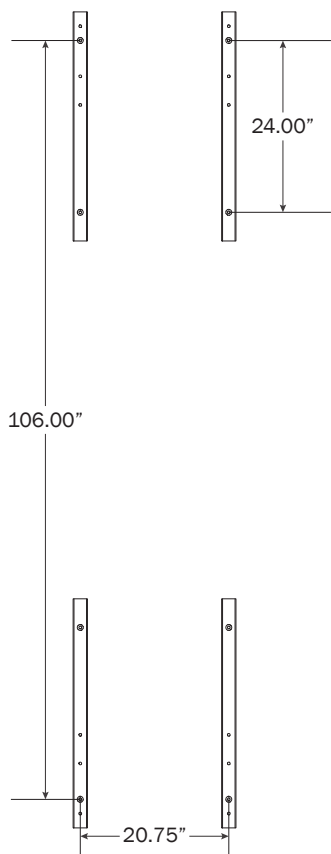

0.4 Assemble unto vehicle roof as shown, then torque the Mounting Feet nuts to 130 in-lbs.

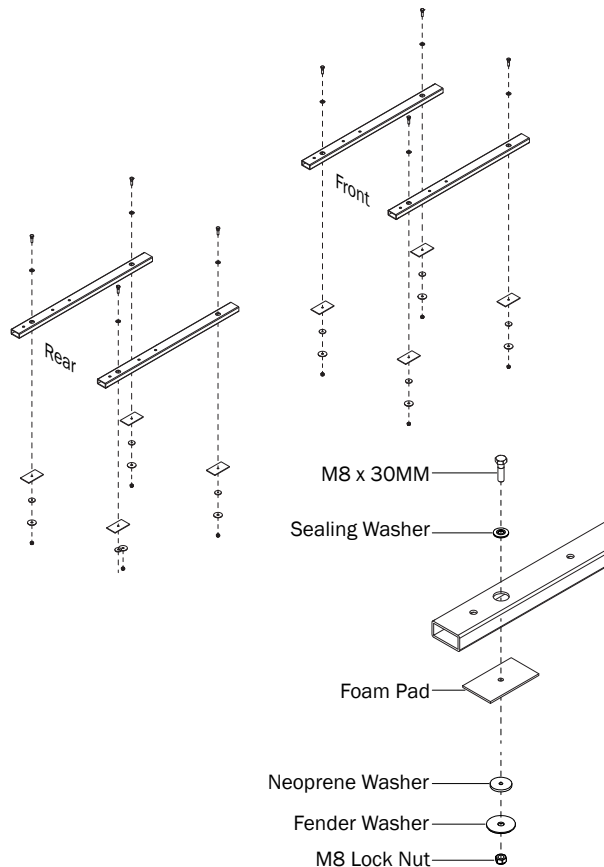

RIGHT ROTATION ASSEMBLY SEQUENCE

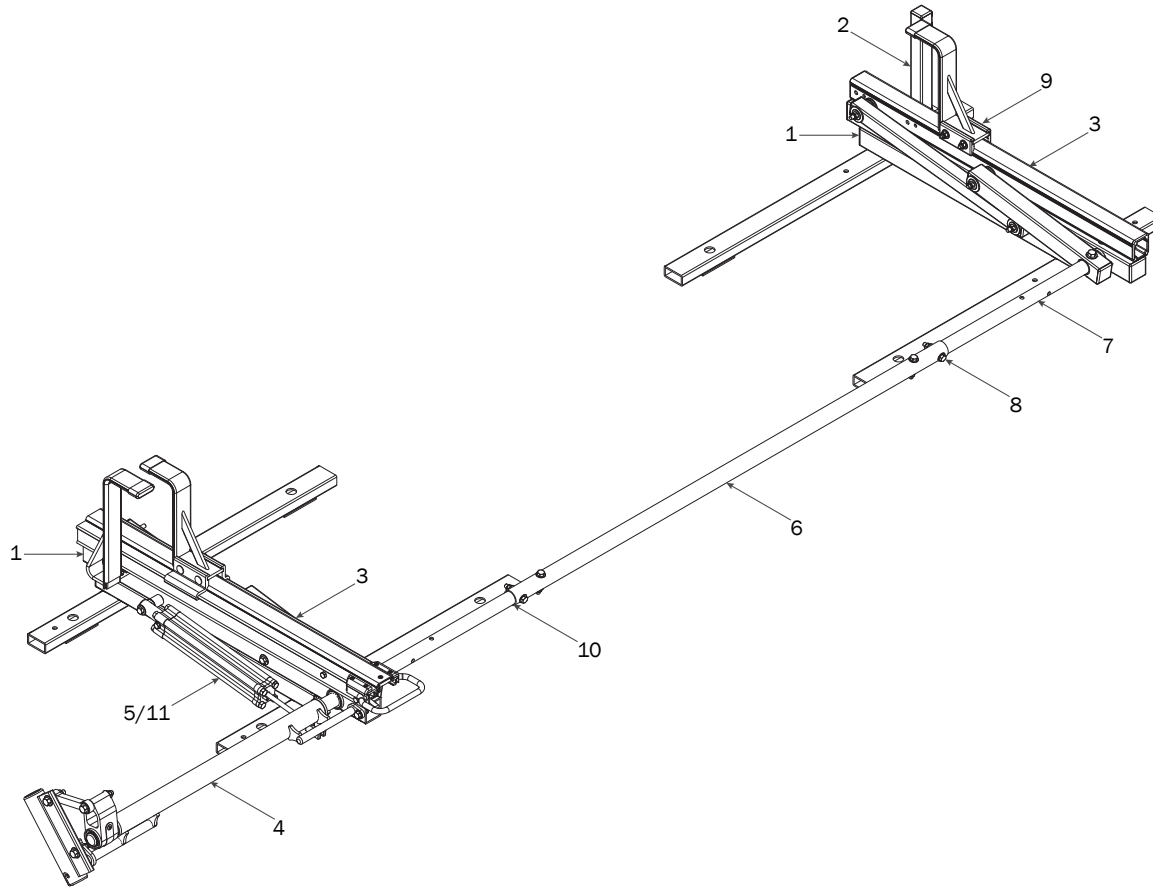

MOUNTING BASE—24.00"

- 1 Center the 24" Mounting Base onto Mounting Brackets.

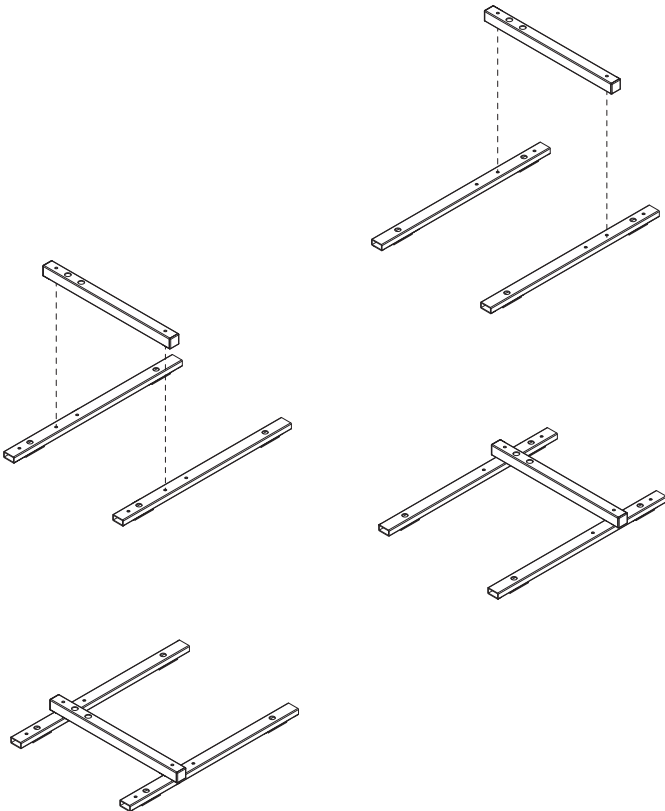

L POST

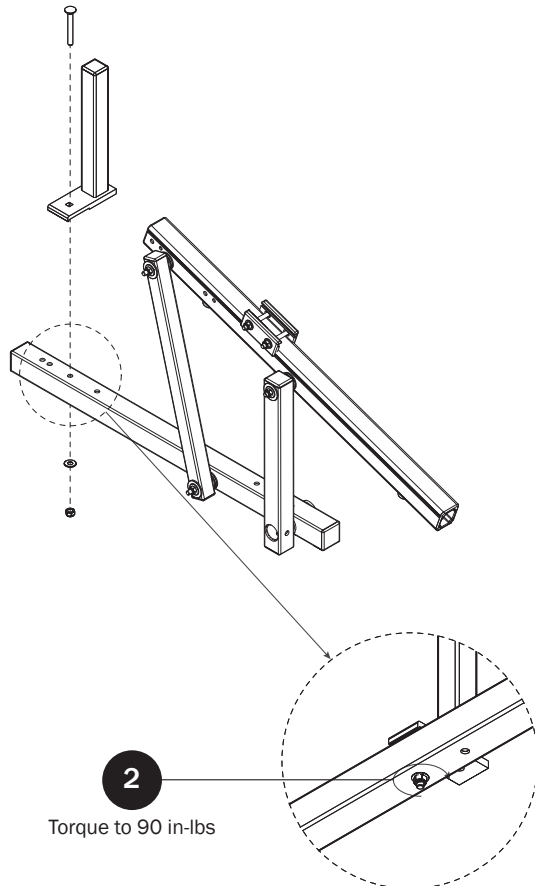

CROSSBARS

3 Attach the Crossbars to the Mounting Brackets using the supplied hardware and torque to 90 in-lbs.

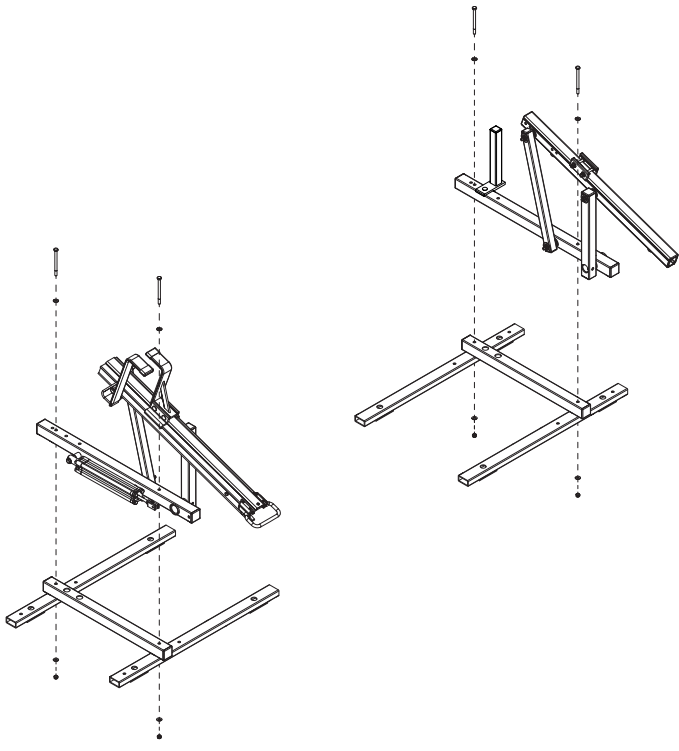

REAR DRIVE SHAFT

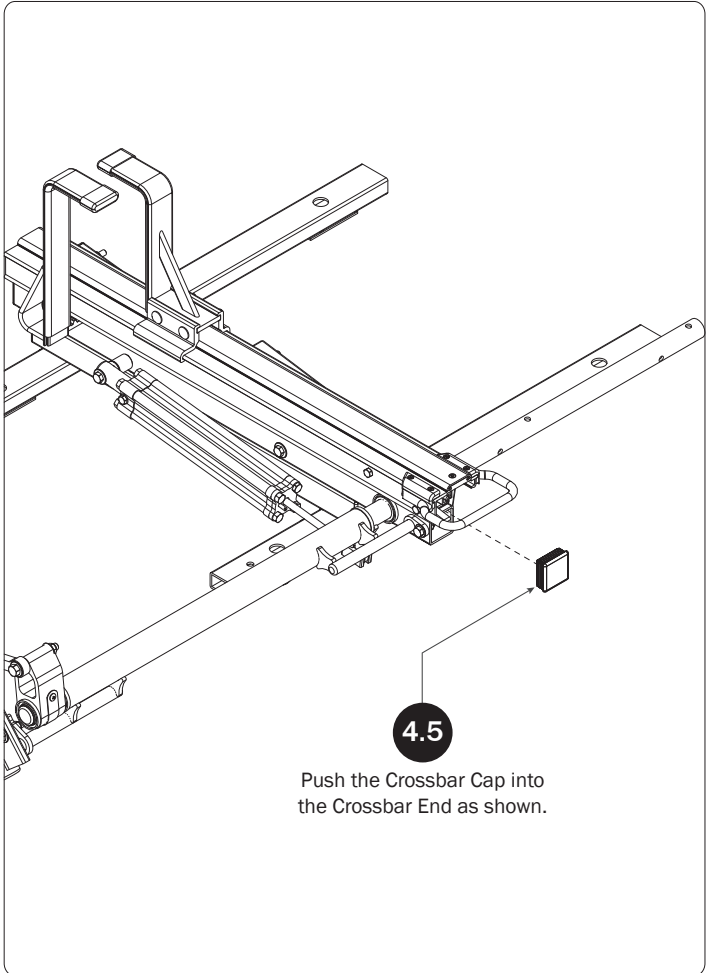
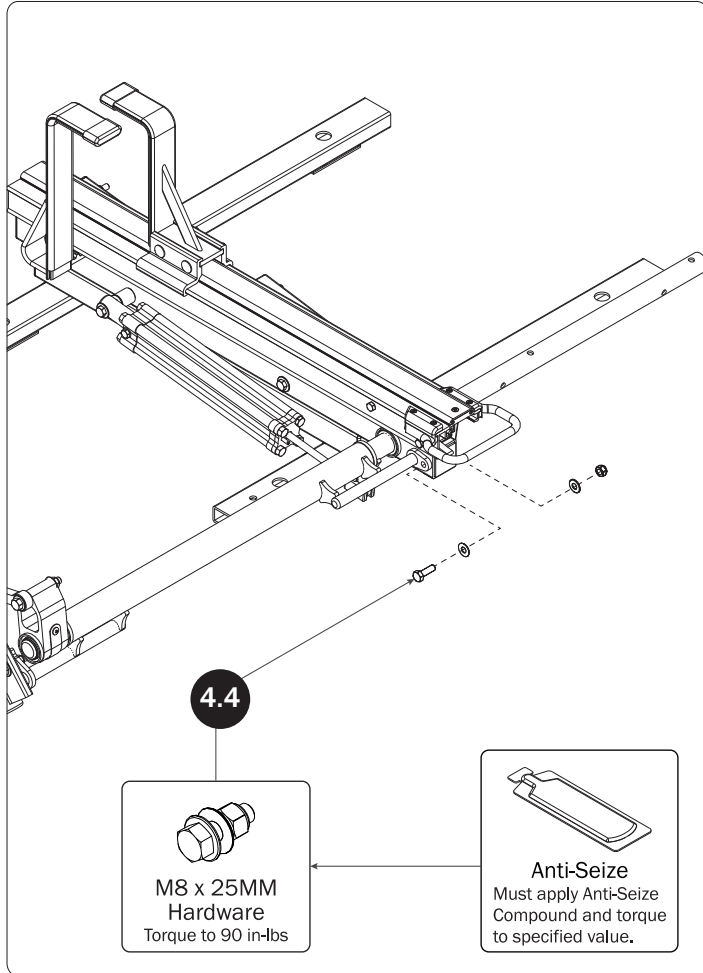
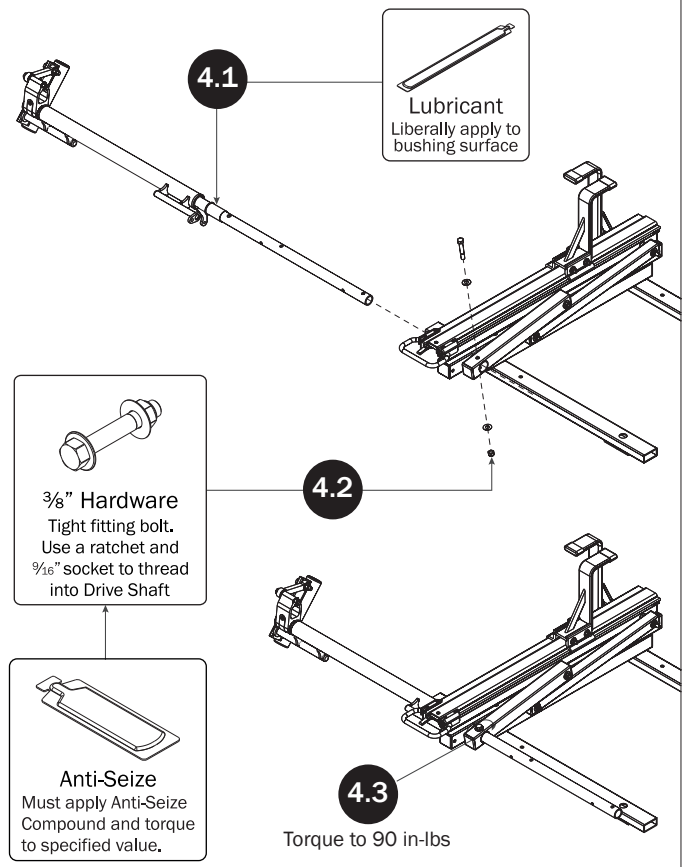

CYLINDER HARDWARE

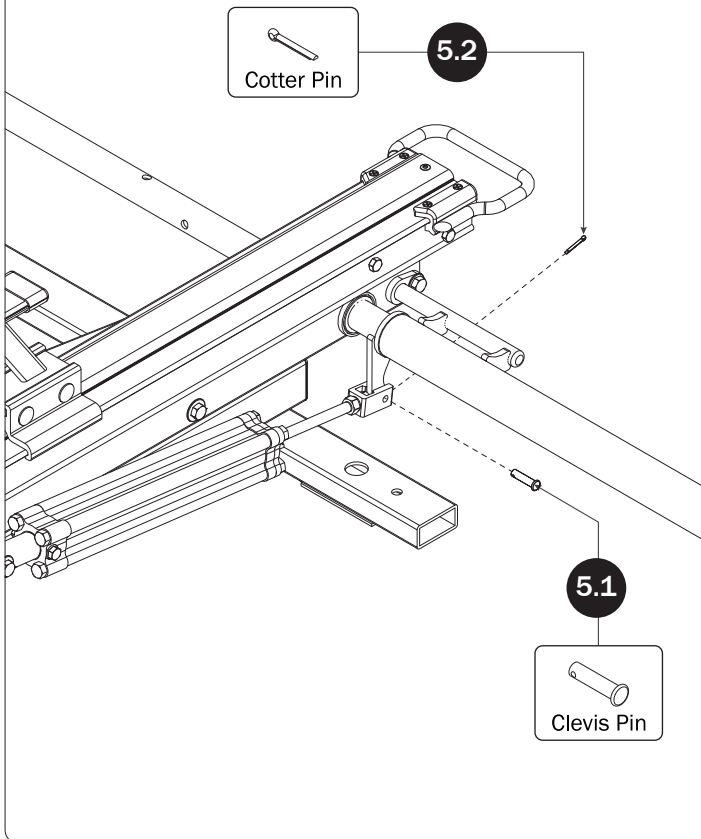

CONNECTING BAR

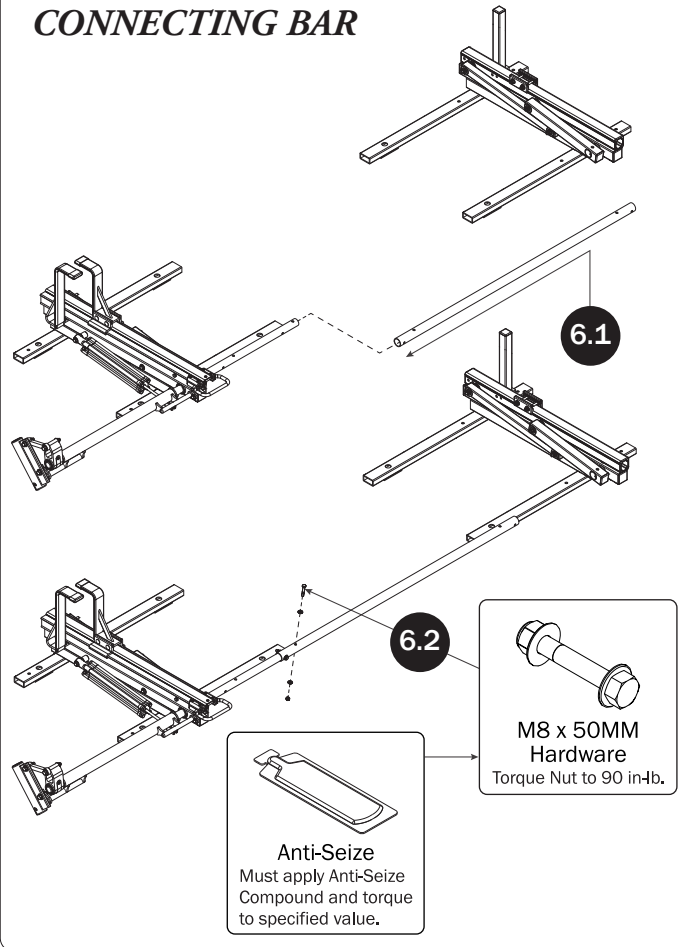

FRONT DRIVE SHAFT

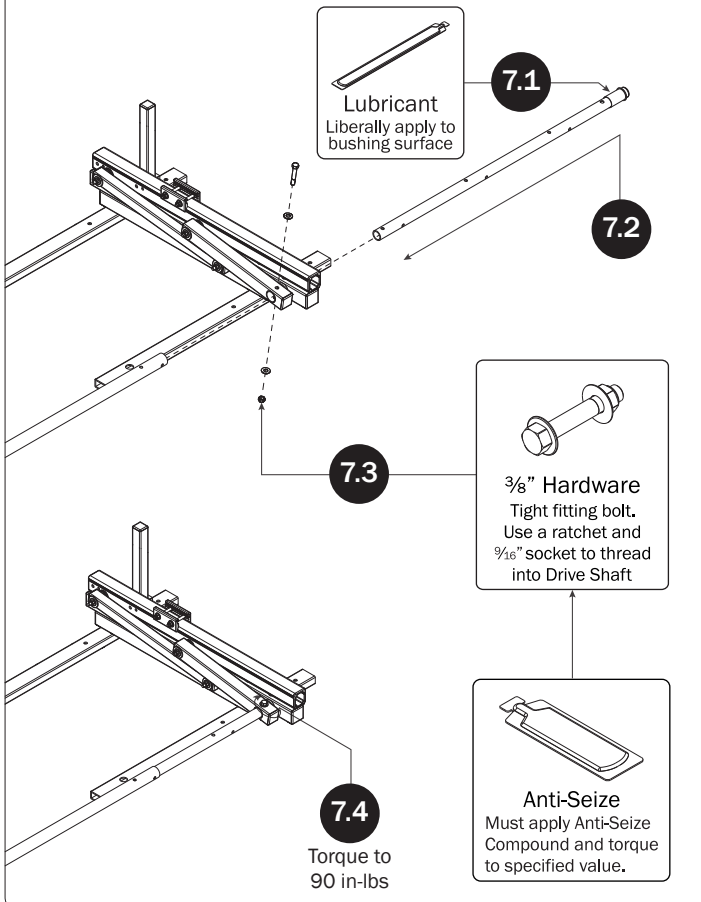

CONNECTING BAR FASTENERS

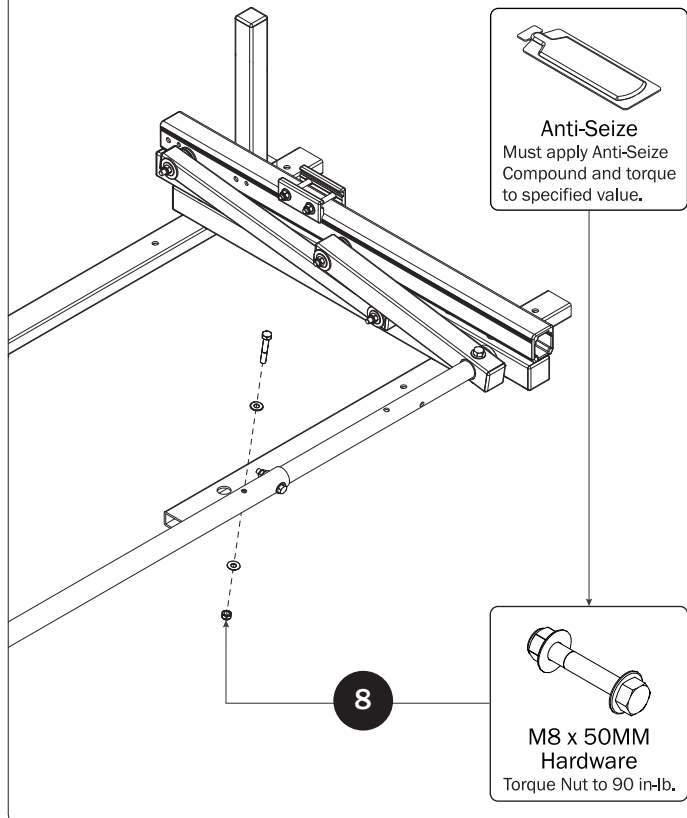

Z POST

SEE QUICK START GUIDE FOR ADJUSTMENTS

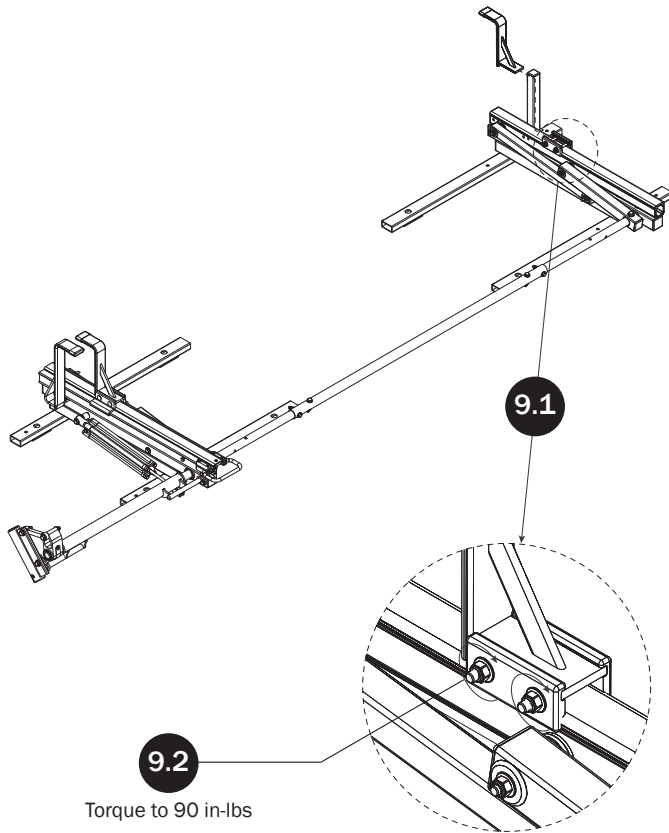

DRIVE SHAFT SEALING

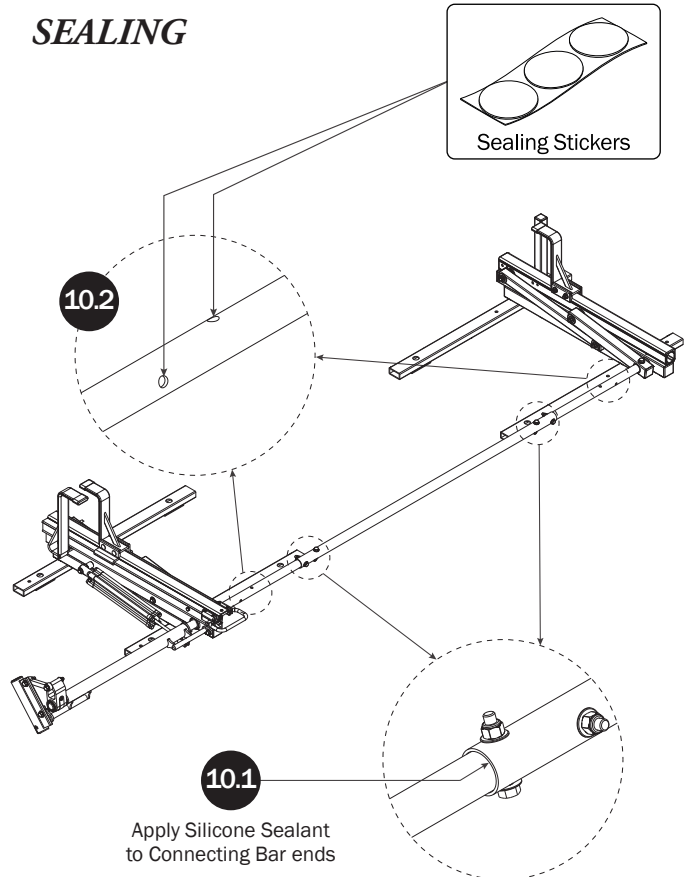

CYLINDER ADJUSTMENT

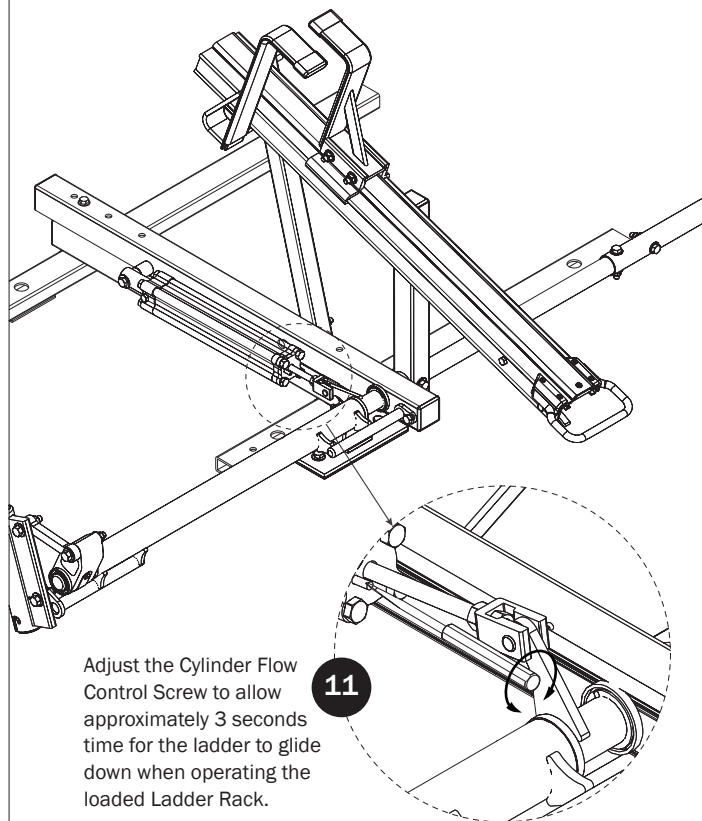

USAM-HXR009E-US01 Rev-A 0220