

HBR-E-NV-HM

ErgoRack, Nissan NV

Two Crossbars, Powder Coat Finish
Rack Weight (empty): 76 lbs

*Callouts in this Configuration Overview indicate full module assemblies only.

For details on individual parts, please refer to the linked Module Overviews below.

- A: [FBM-1010-BLK Mounting System](#)
- B: [CBA-3007 Hybrid Crossbar Assembly](#)
- C: [FEA-0019 Rotation Driveshaft Assembly](#)

[Modular Assembly Manuals](#)

ErgoRack Van—Load specifications:

Check vehicle manufacturer recommendations for roof capacity weight limits.

CROSSBAR SPACING	STEP LADDER	EXT. LADDER
4 ft Spacing	6 – 8 ft.	16 – 20 ft.
5 ft Spacing	8 – 10 ft.	16 – 24 ft.
6 ft Spacing	8 – 12 ft. [†]	16 – 28 ft.
7 ft Spacing	10 – 12 ft. [†]	20 – 32 ft.
8 ft Spacing	10 – 12 ft. [†]	20 – 36 ft.

[†]Rotation Configurations: 12 ft. step ladders require an extended upper add-on component.

*Example shown with H1 (84" Roof Height) Configuration

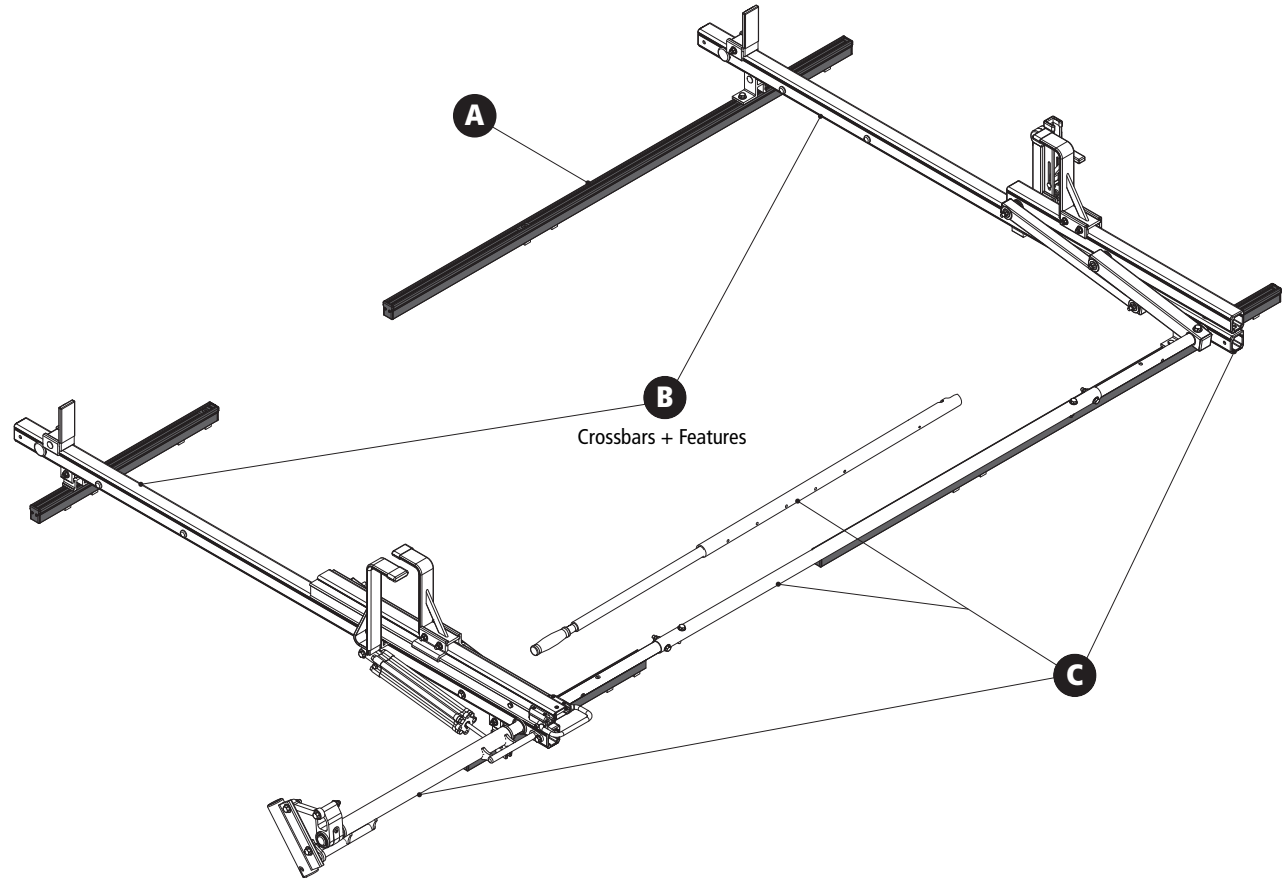

HBR-E-NV-HM

ErgoRack, Nissan NV

Approximate dimensions as shown:

All Heights

- A: Rack Width 76"
- B: Rack Height 16.50"
- C: Rear Crossbar Offset (L&R) Even
- D: Mount Spacing L/R Set at install

H1 (84")

- E: Total Crossbar Spacing 6'–8'
- F: Rack Length 108"–132"

H2 (105")

- G: Total Crossbar Spacing 6'–7'
- H: Rack Length 105–117"

Compatible Accessories Available

(Sold Separately)

- Retractable Ratchet Tie-Down [ACC-8000](#)
- Rear Access Ladder [AAL Series](#)
- 8'–12' Conduit Carriers [CON Series](#)
- WorkPro LED Lighting [LED Series](#)
- Systems and Safety Components [RVS Series](#)
- Safety monitoring [DS2 Series](#)

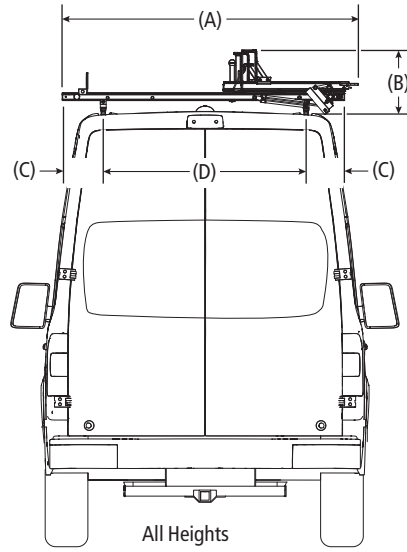

Rear Drive Shaft Offset: 29"

Note: The end of the driveshaft must not extend beyond the vehicle bumper

