

PRIME DESIGN™

A Safe Fleet Brand

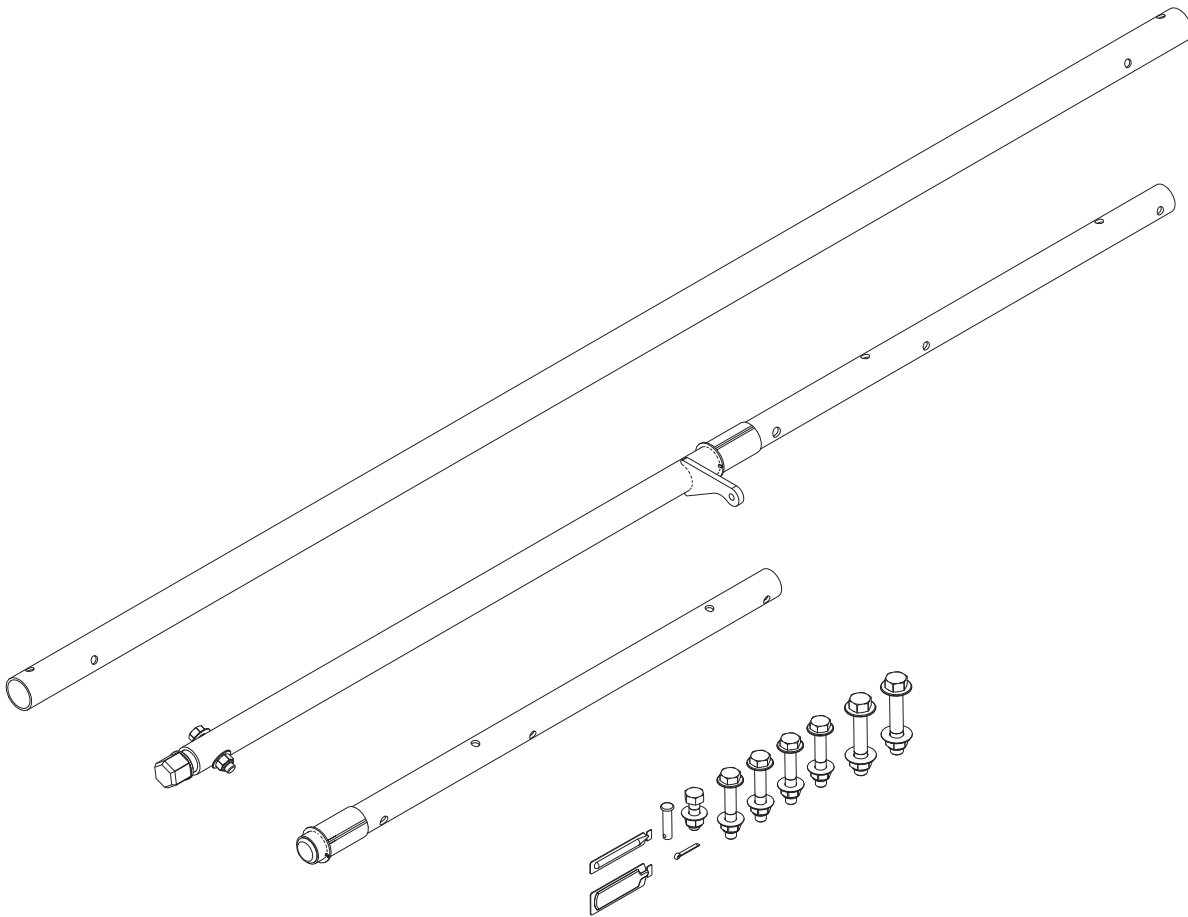

FEA 00009

PRIME DESIGN, A SAFE FLEET BRAND

Address: 580 Opperman Drive, Eagan, MN 55123 • Toll Free: 1.8.PRIME.RACK

Fax: 651-552-1799 • Email: info@primedesign.net • Website: www.primedesign.net

CONTENTS OVERVIEW

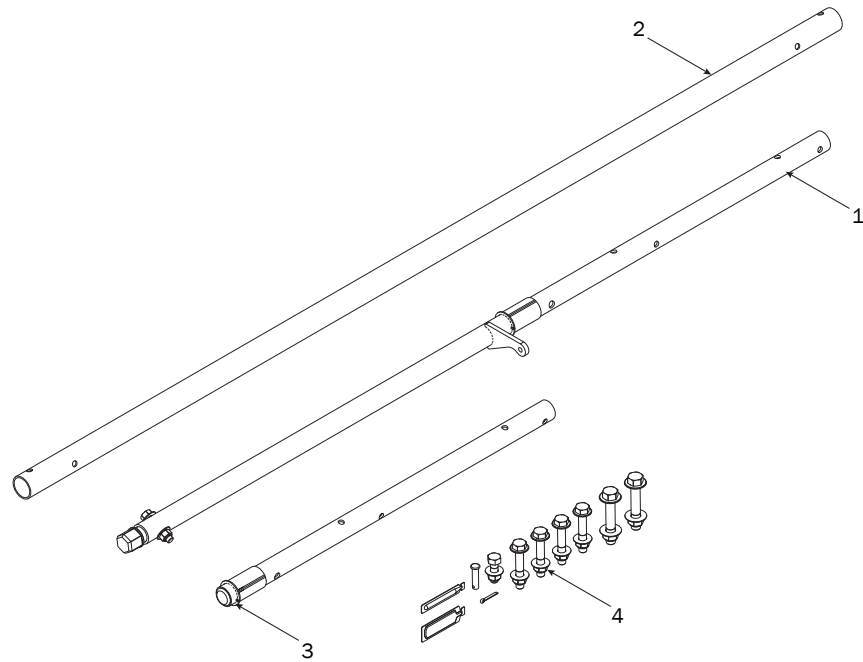

1—Drive Shaft (Qty 1)
Rear, Ratchet Handle

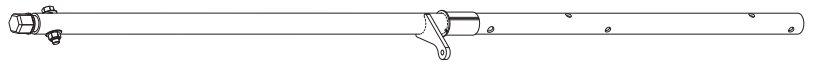

2—Connecting Bar (Qty 1)
60.00"

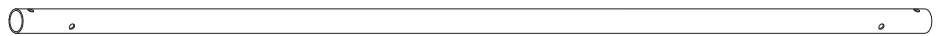

3—Front Drive Shaft (Qty 1)
B Version, 23.75"

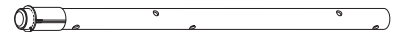

4-HKT-8163..... (Qty 1)
Modular High Roof Rotation Hardware Kit

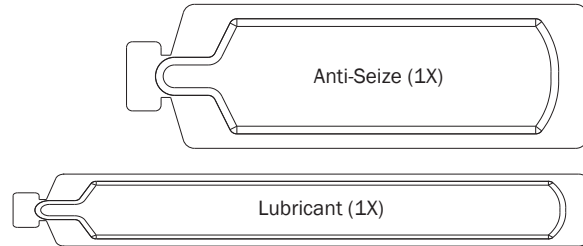
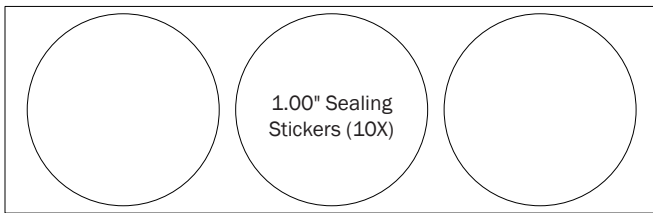
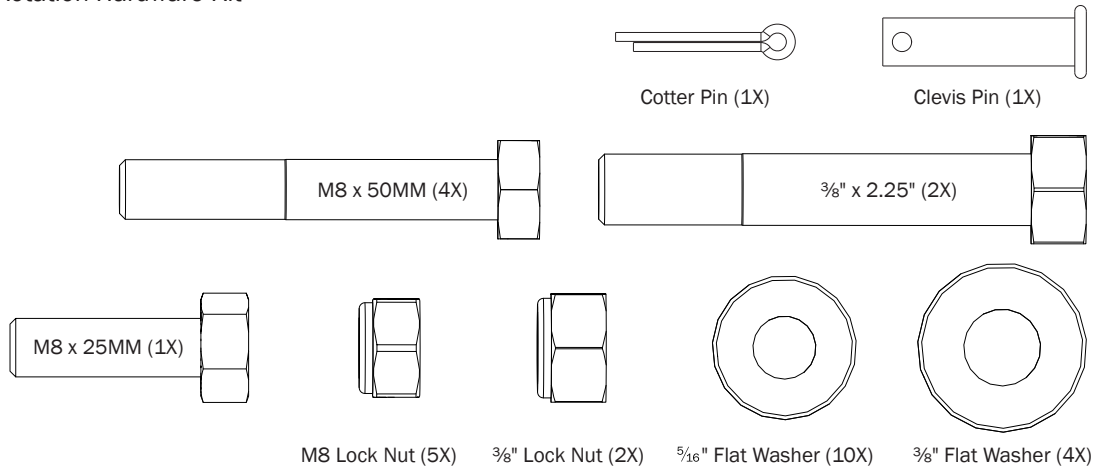

DRIVE SHAFT ASSEMBLY SEQUENCE



NOTE: Crossbars and RH Rotation feature are shown for illustrative purposes only. Crossbars and Rotations are not included with this Drive Shaft feature, and must be purchased separately.

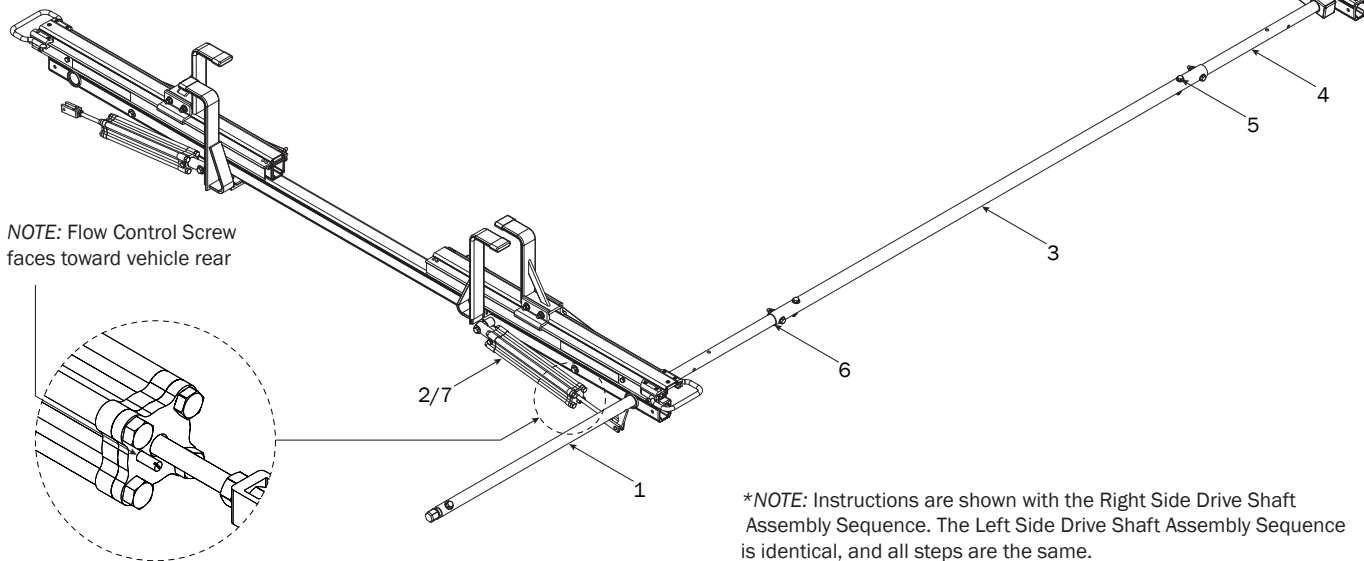

REAR DRIVE SHAFT

NOTE: For instructional clarity, the FBM Mounting System will not be shown for the remainder of this Assembly Manual.

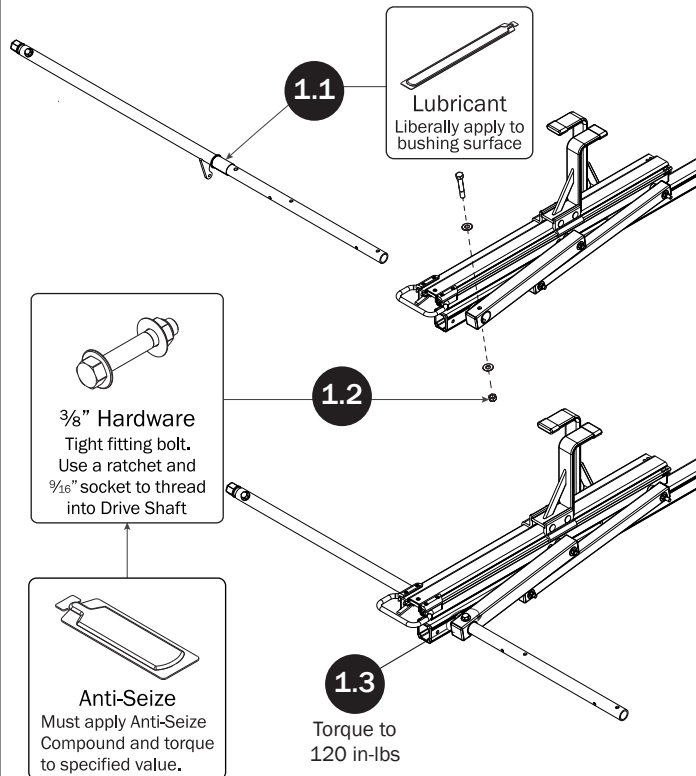

CYLINDER HARDWARE

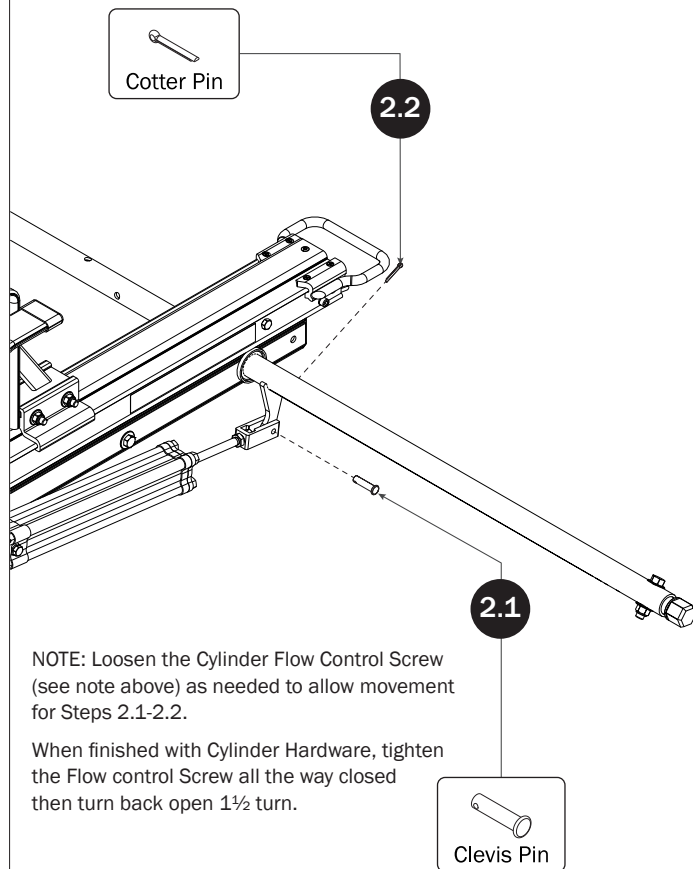

CONNECTING BAR

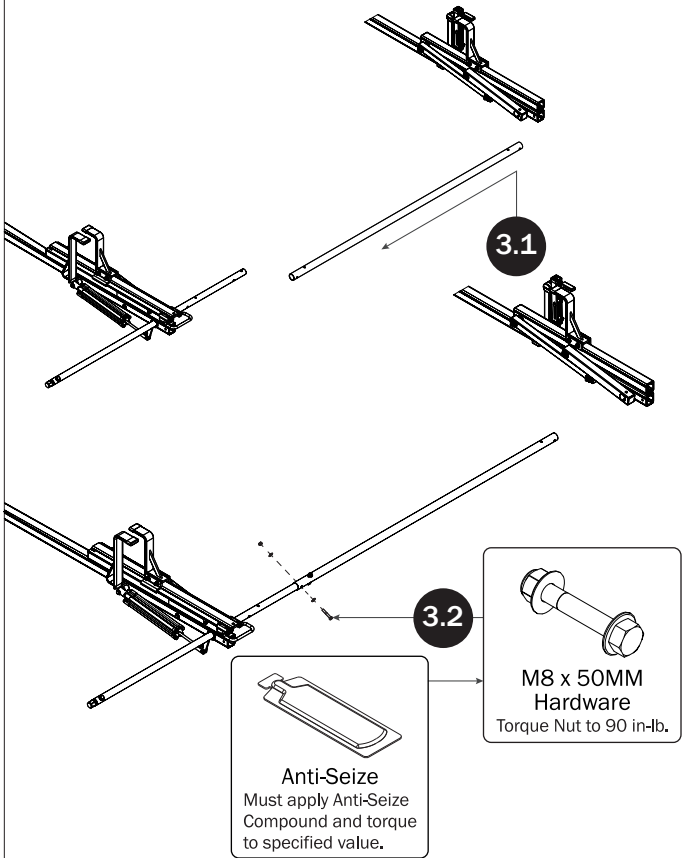

FRONT DRIVE SHAFT

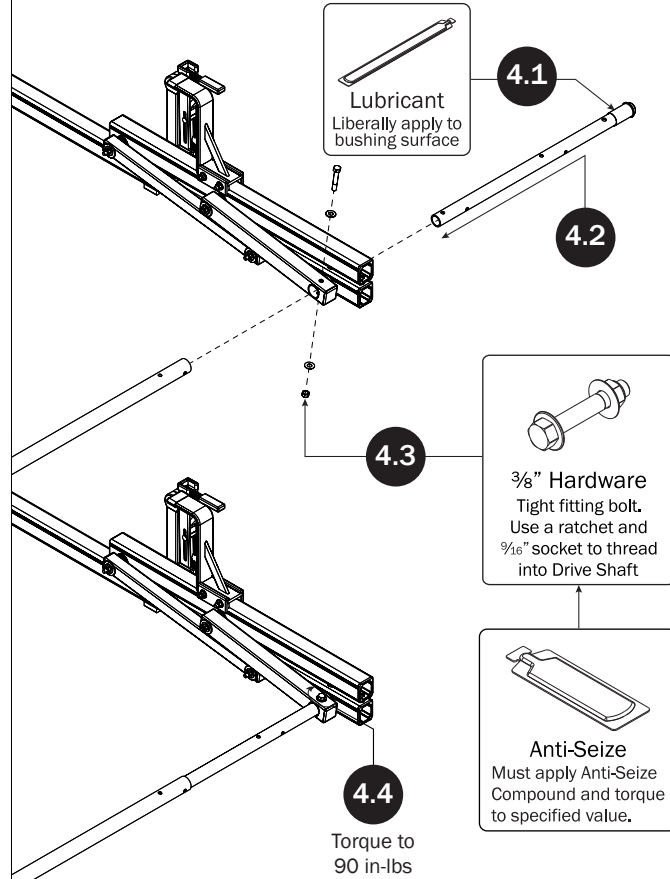

CONNECTING BAR FASTENERS

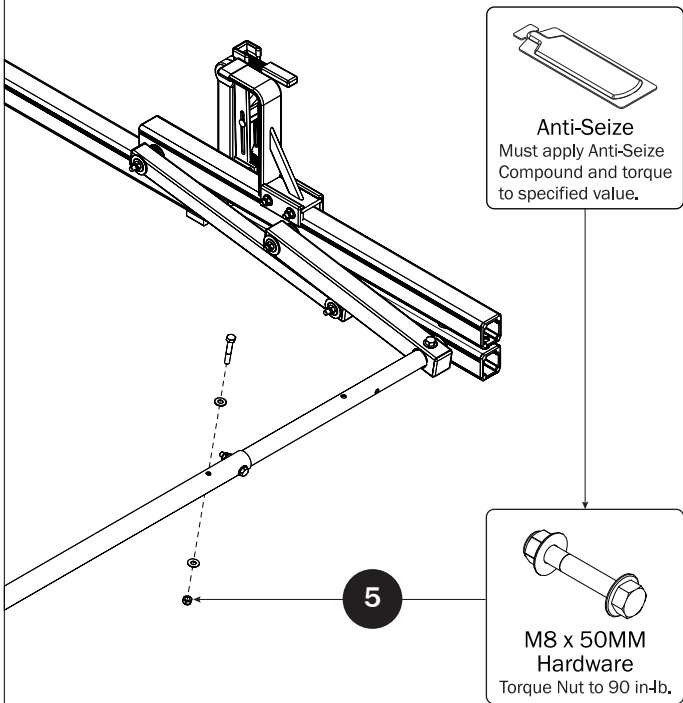

DRIVE SHAFT SEALING

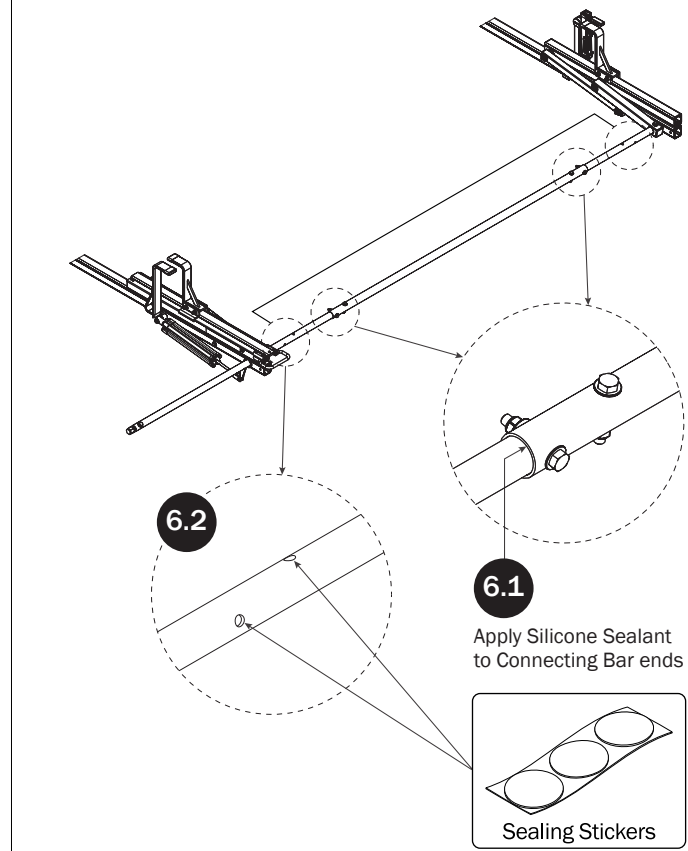

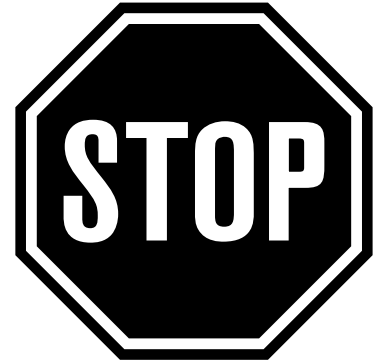
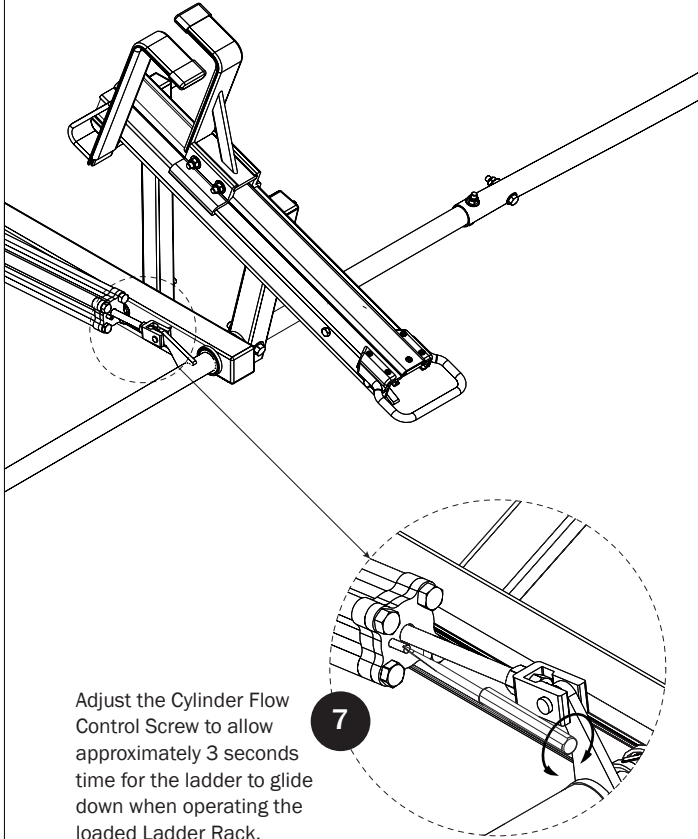
CYLINDER ADJUSTMENT

NOTE: This completes the assembling of FEA-0009. If applicable, refer to your next FEA Assembly Manual.

If completed, refer back to your FBM Assembly Manual, and resume assembling at Step 3.1.

WARNING: Failure to position the Crossbars as shown in your FBM Assembly Manual may result in damage to the sliding door and/or ladder rack.

Page Intentionally Left Blank

