

PRIME DESIGN™

A Safe Fleet Brand

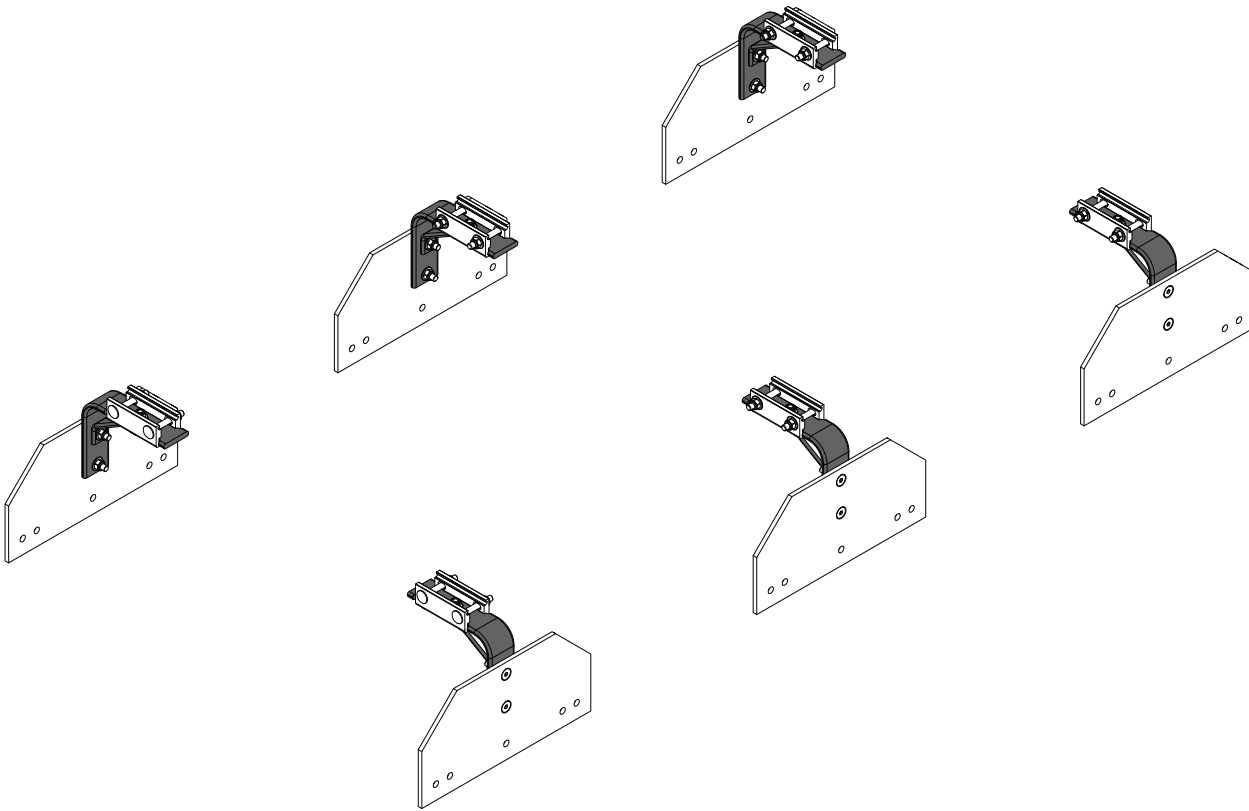

PRIME RACK

FBM-1027

90° Sidewall Mount Frame Base Mounting Kit

Page 2	Packaging Contents
Pages 3-6	Utility Roof Mountings

CONTENTS OVERVIEW



Installer's Note: Due to the variety of different applicable vehicles and cargo bodies, this Rack model does not come with included body fastening hardware, and must be supplied by the installer.

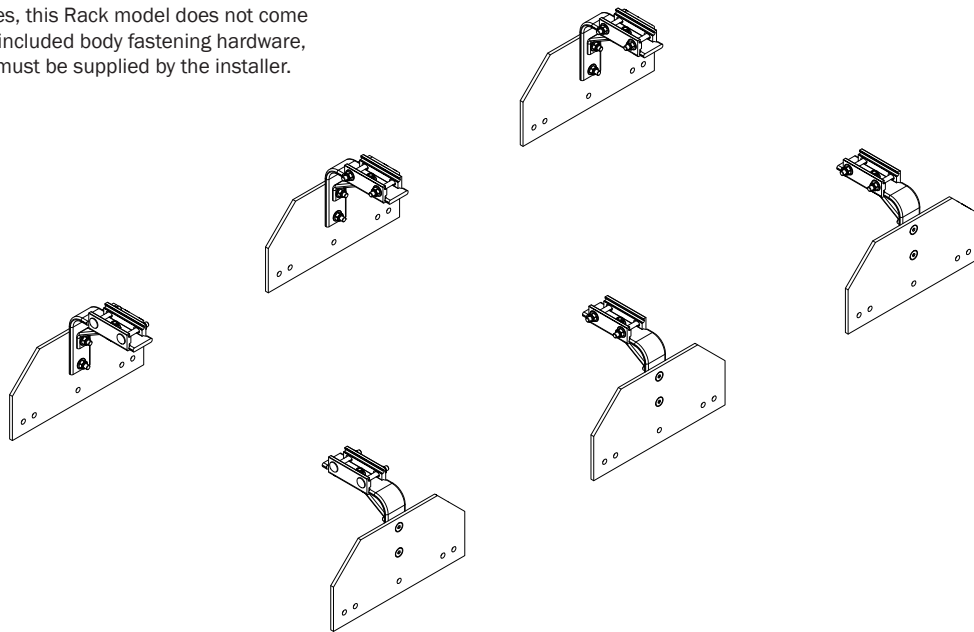

1—FBM-1027-BLK..... (Qty 1)
Sidewall Mounts, 90° with HKT-8418



Crossbar Mounting Bracket, Pair (6X)



Mounting Brace (6X)

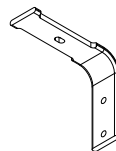

Side Wall Mounting Bracket, 90° (6X)

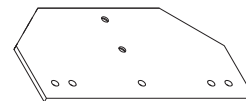

Side Wall Mounting Plate, 90° (6X)

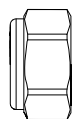

Lock Nut (30X)

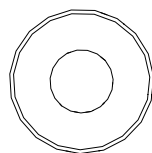

Flat Washer (36X)

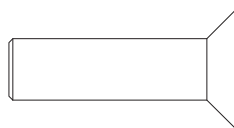

M8 x 30MM Allen Flat Head Screw (6X)

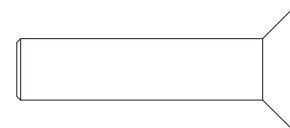

M8 x 35MM Allen Flat Head Screw (6X)

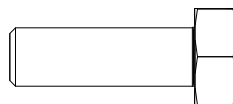

M8 x 25MM Bolt (6X)

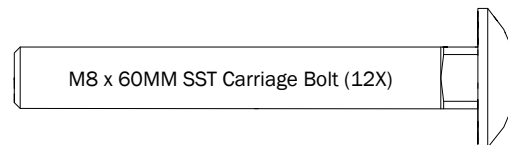

M8 x 60MM SST Carriage Bolt (12X)

2—Gen4 Crossbars (not shown above)..... (Qty 1)
Ordered separately, Front, Rear, Center, 84+”

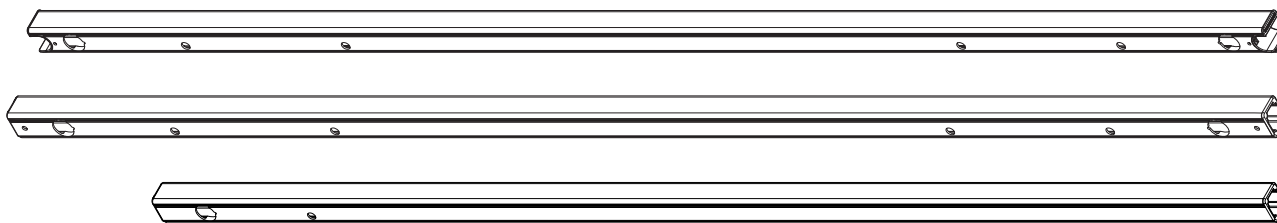

BRACKET PRE-ASSEMBLY

- 0.1** Attach all six Mounting Braces to the Mounting Brackets using the M8 x 25MM Bolts, Flat Washers and Locknuts as shown. Torque to 90 in-lbs.

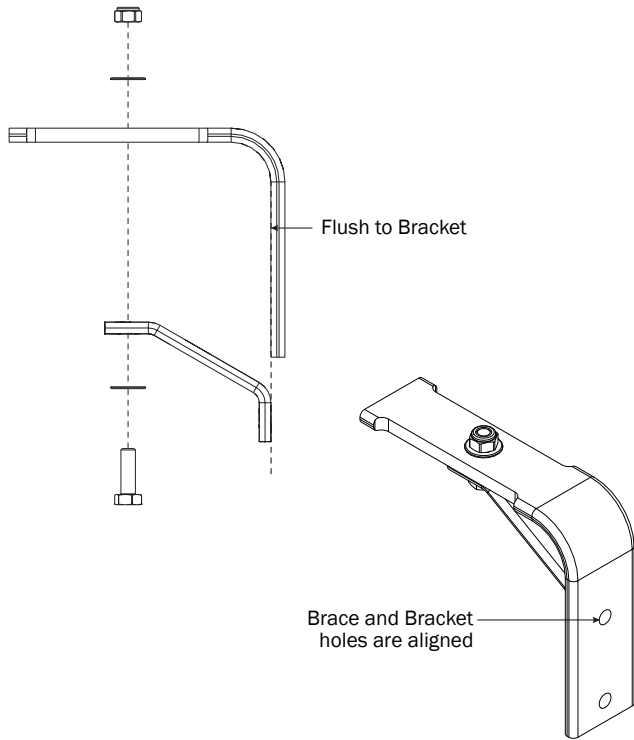

- 0.2** Attach all six Mounting Brackets to the Mounting Plates using the M8 Allen Flat Head Screws, Flat Washers and Locknuts as shown, and tighten.

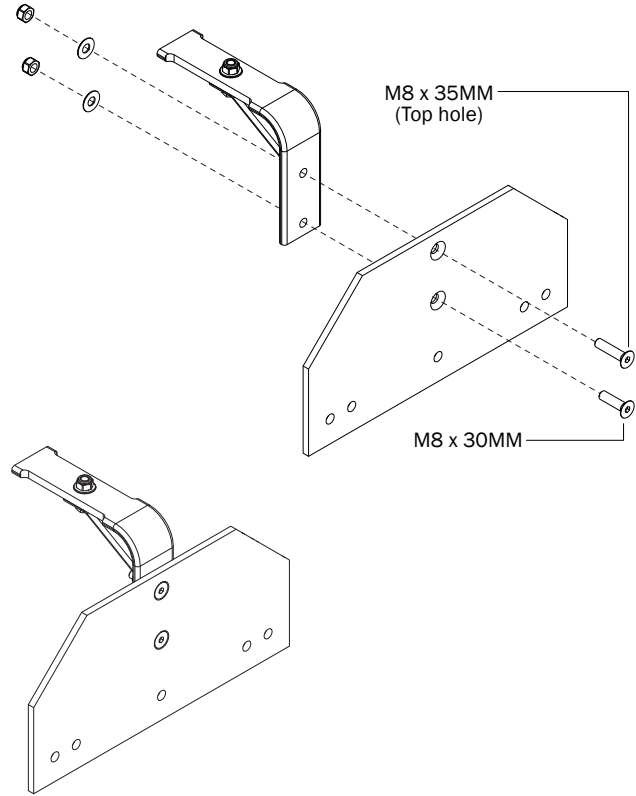

MOUNTINGS

- 1.1** Dimension A shows the total distance from the end of the Rear Drive Shaft to the center hole of the Rear Mounting.

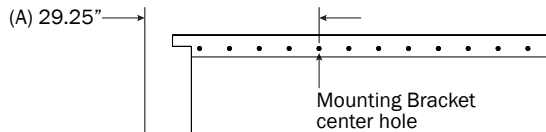

- 1.3** Compare the distances of the screws or rivets on the vehicle body to the illustration below. Beginning at the center hole on the Mounting Bracket, measure against the screws or rivets to the left and right of the designated center hole as shown on Step 1.1.

If the vehicle's OEM bolt holes do not align with those on the Mounting Bracket, it will be necessary to drill the vehicle body to accommodate either set of Mounting Bracket holes B or C.

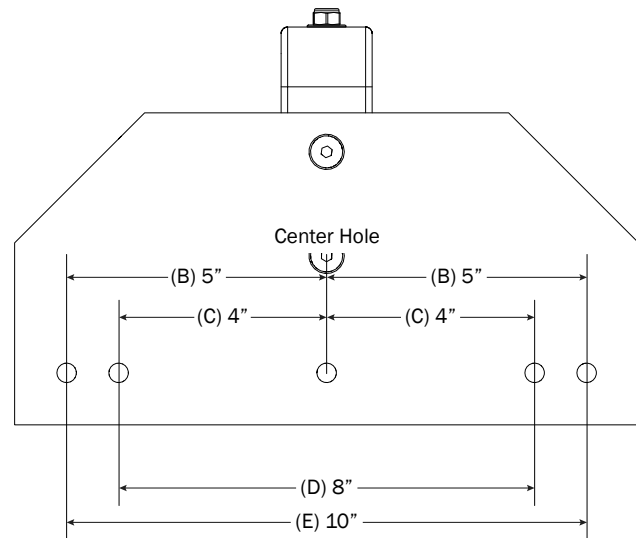

1.2

To prevent damage to the vehicle and/or Ladder Rack, ensure the Rear Drive Shaft does not protrude past the bumper as shown.

1.4

The Mounting Bracket must sit flush against the vehicle's body. Remove as many bolts or rivets from the area directly behind the Mounting Bracket as needed for a flush fit.

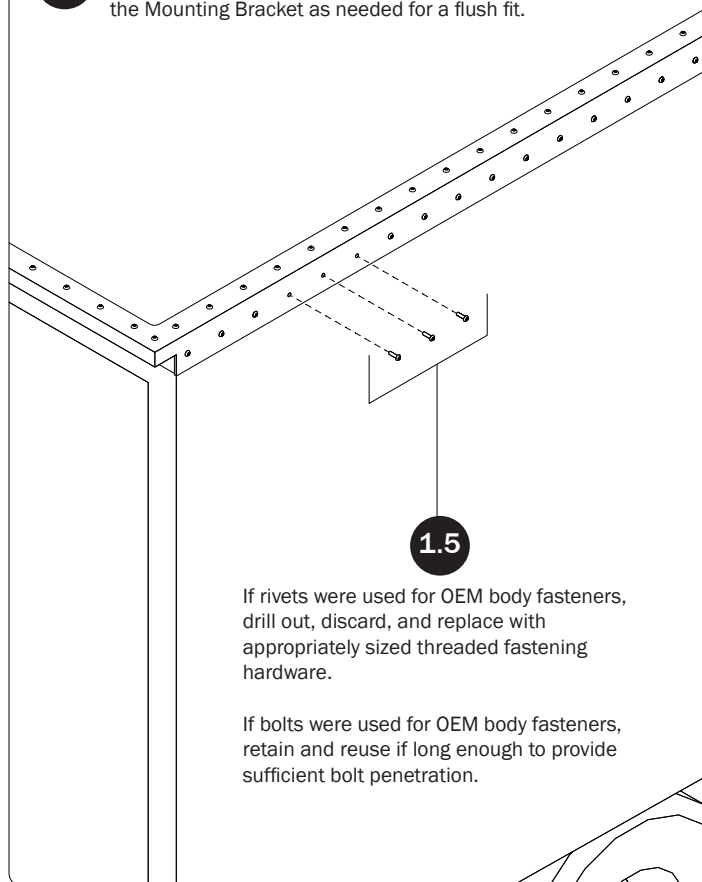

1.5

If rivets were used for OEM body fasteners, drill out, discard, and replace with appropriately sized threaded fastening hardware.

If bolts were used for OEM body fasteners, retain and reuse if long enough to provide sufficient bolt penetration.

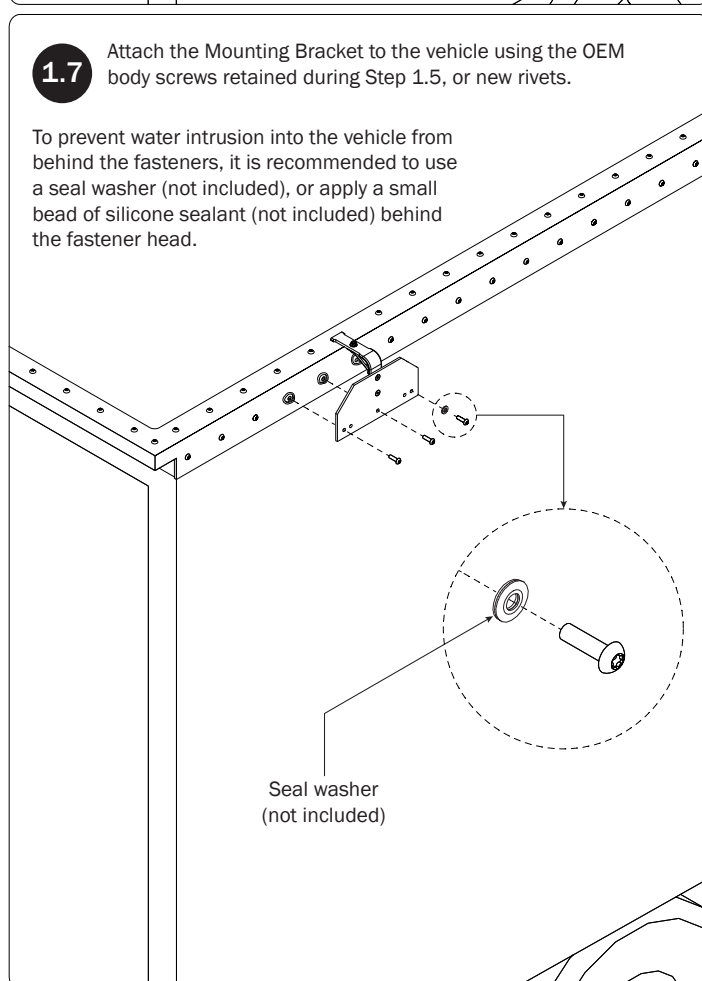

Seal washer
(not included)

1.7

Attach the Mounting Bracket to the vehicle using the OEM body screws retained during Step 1.5, or new rivets.

To prevent water intrusion into the vehicle from behind the fasteners, it is recommended to use a seal washer (not included), or apply a small bead of silicone sealant (not included) behind the fastener head.

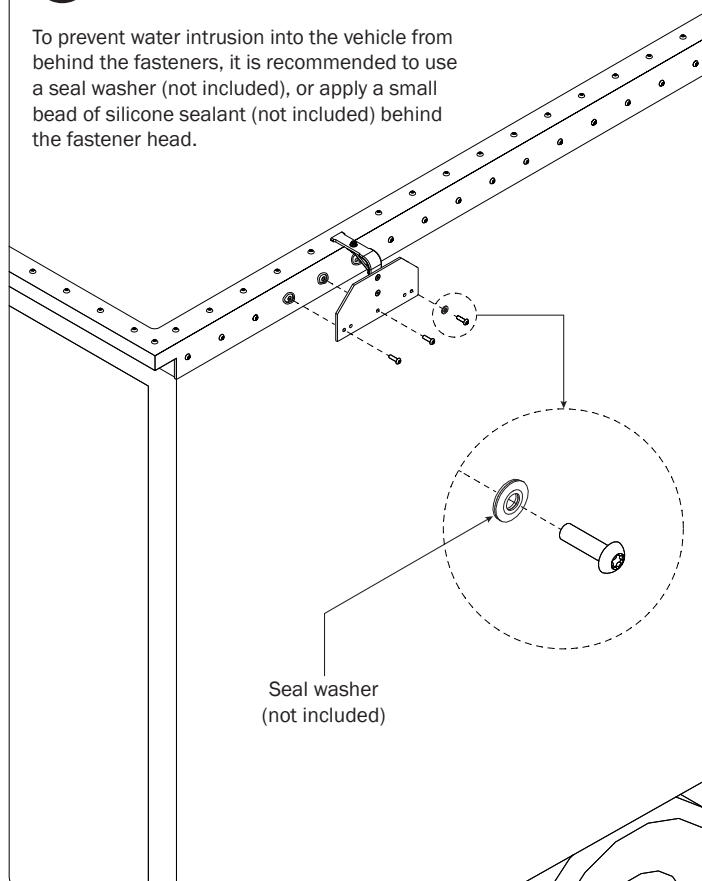

1.6

To prevent water intrusion into the vehicle from behind the Mounting Bracket, it is recommended to apply a small bead of silicone sealant (not included) around the holes of all removed bolts or rivets.

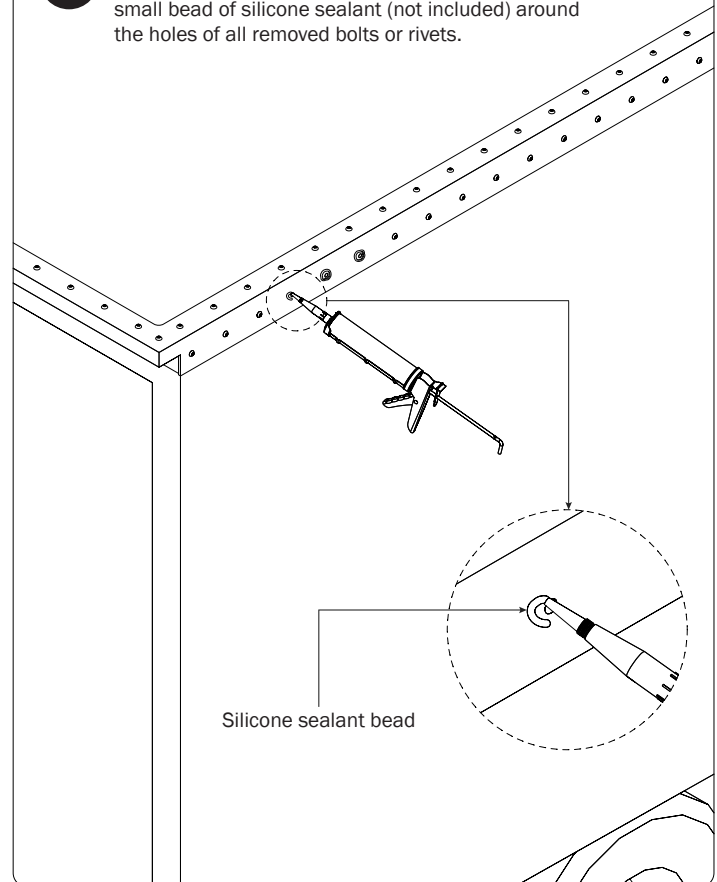

Silicone sealant bead

1.8

Torque bolts (if used)
to 90 in-lbs.

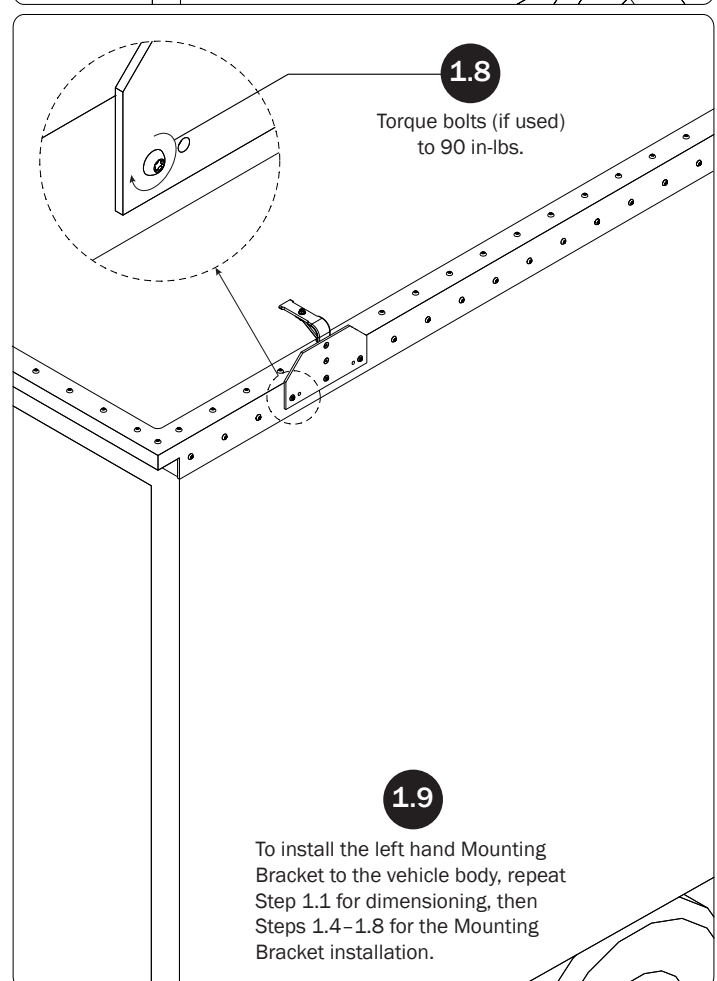

1.9

To install the left hand Mounting Bracket to the vehicle body, repeat Step 1.1 for dimensioning, then Steps 1.4–1.8 for the Mounting Bracket installation.

- 2.1** This rack model can be set for a Crossbar spacing distance of 6' to 8'. Dimensions F and G illustrates the Rear to Center, and Center to Front Crossbar allowable spacing. Dimension H illustrates the maximum allowable Crossbar spacing from the Rear to the Front Crossbars.

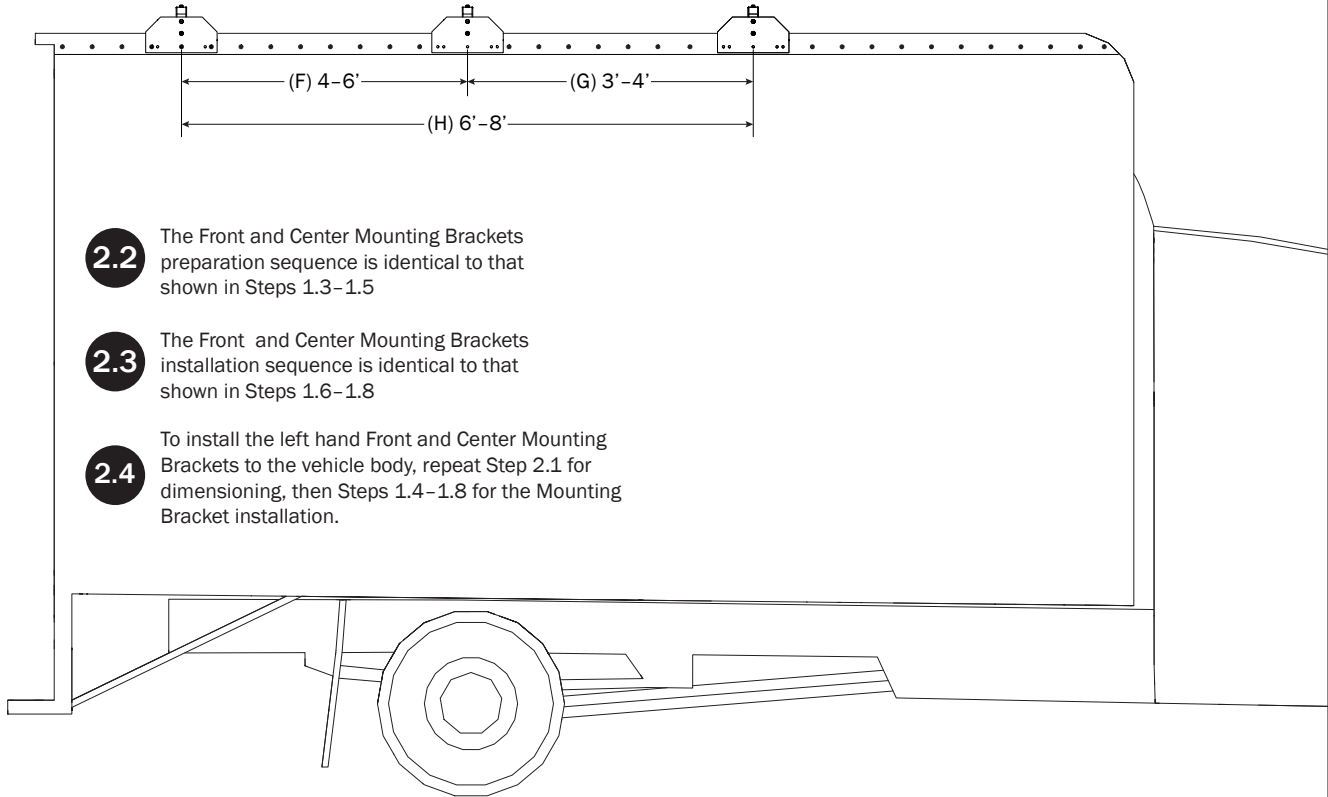

- 2.2** The Front and Center Mounting Brackets preparation sequence is identical to that shown in Steps 1.3-1.5
- 2.3** The Front and Center Mounting Brackets installation sequence is identical to that shown in Steps 1.6-1.8
- 2.4** To install the left hand Front and Center Mounting Brackets to the vehicle body, repeat Step 2.1 for dimensioning, then Steps 1.4-1.8 for the Mounting Bracket installation.

- 2.5** Attach Crossbar Clamps to the Mounting Brackets with the Carriage Bolts, Flast Washers and Locknuts as shown.

NOTE: Recommended Bolt head facing:
Rear Mounts-Bolt heads face rear
Front and Center Mounts-Bolt heads face front

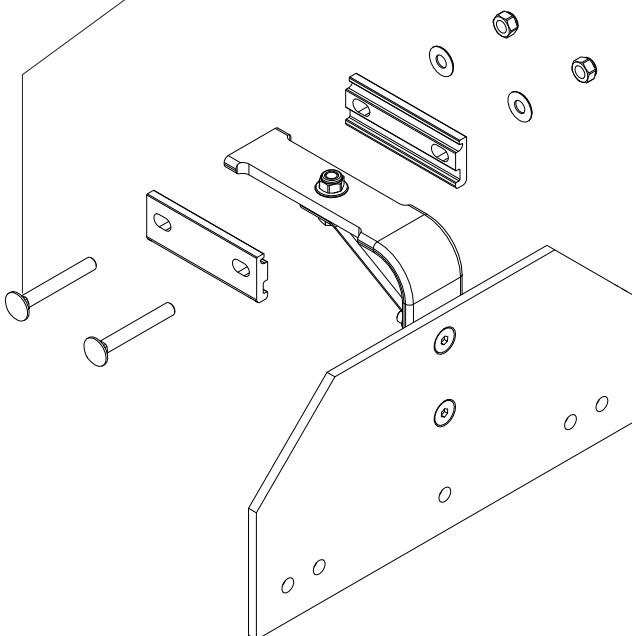

- 2.6** Finger-tighten Clamp Hardware. Do not torque until Crossbars are mounted.

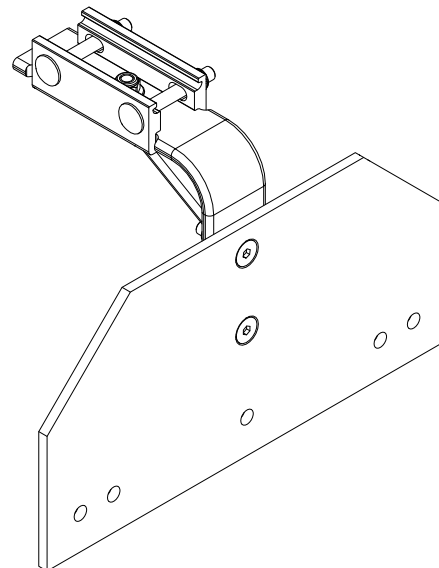

FBM ASSEMBLY SEQUENCE

NOTE: LH/RH Rotation and Crossbar features are shown for illustrative purposes only. These features are not included with this Base Mounting Kit, and must be purchased separately.

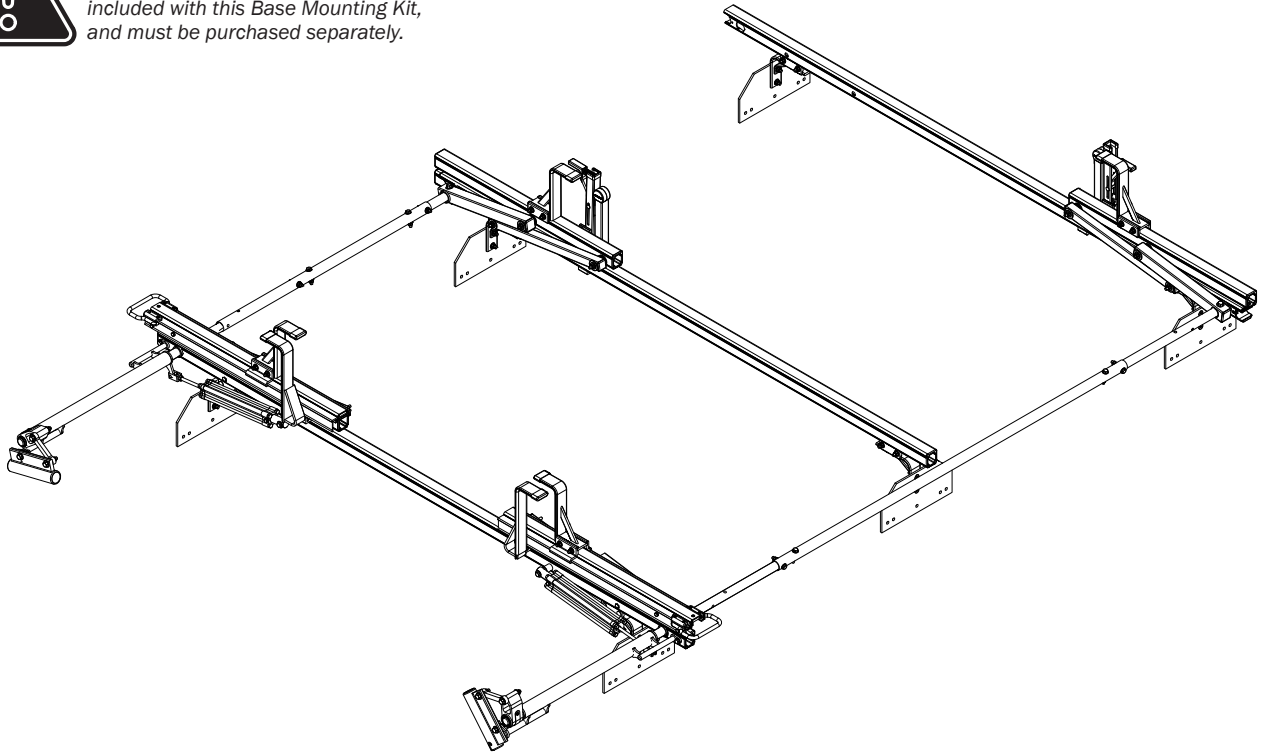
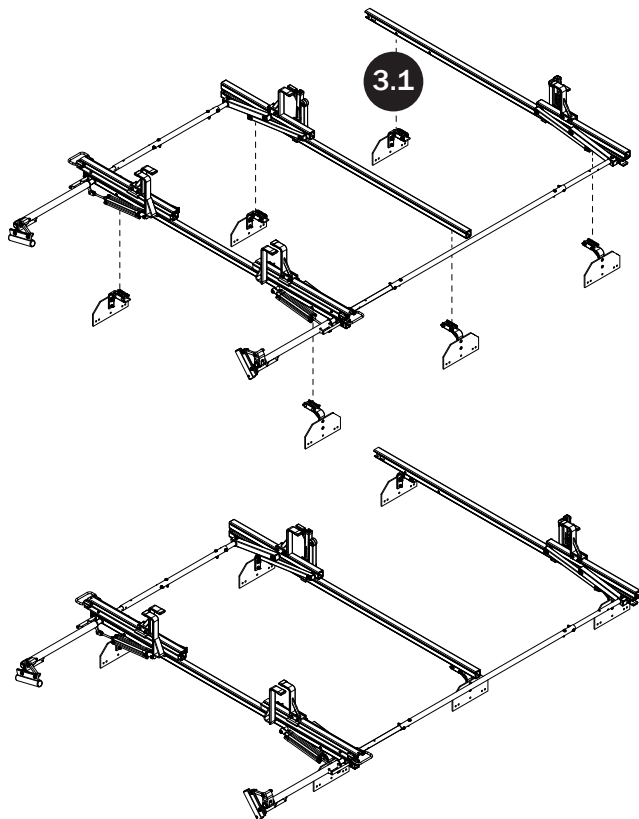
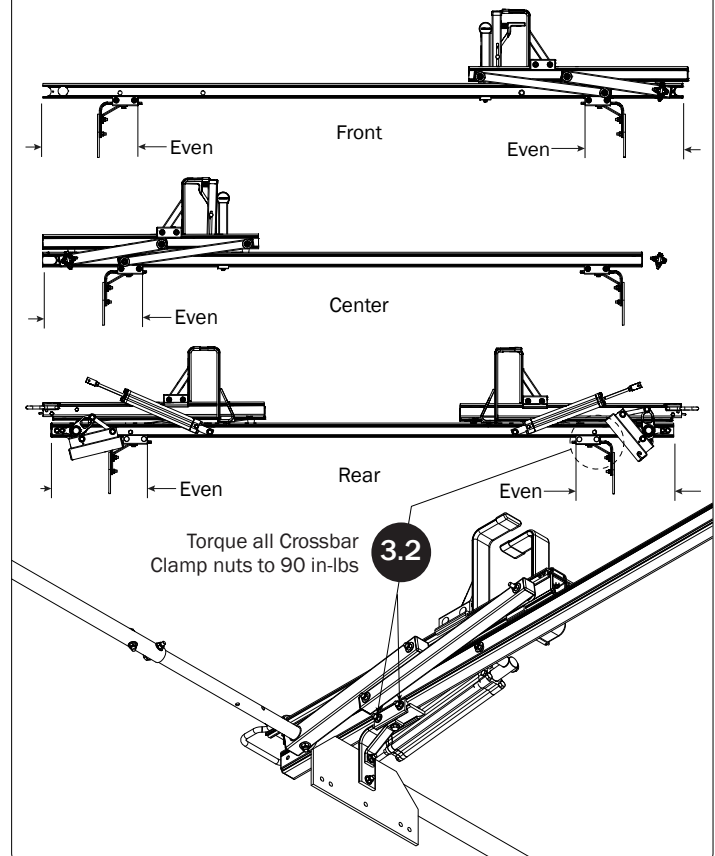
**CROSSBARS****CROSSBAR ADJUSTMENT**

Page Intentionally Left Blank

