

# PRIME DESIGN™

A Safe Fleet Brand

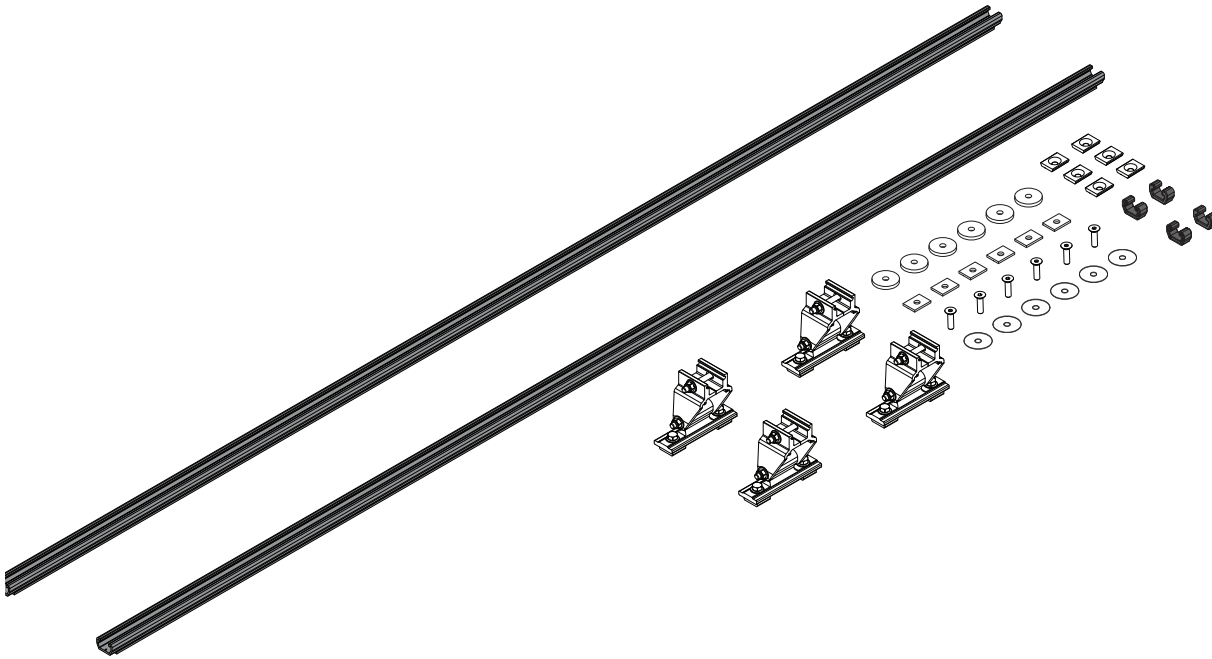

**PRIME**  
**RACK**  
**FBM-1014**

## 2015+ Chevrolet City Express/Nissan NV200 L2H1 Base Mounting Kit

Page 2                      Packaging Contents

Pages 3-6                  Low Roof Medium Wheelbase (115.20")

PRIME DESIGN, A SAFE FLEET BRAND

Address: 580 Opperman Drive, Eagan, MN 55123 • Toll Free: 1.8.PRIME.RACK

Fax: 651-552-1799 • Email: [info@primedesign.net](mailto:info@primedesign.net) • Website: [www.primedesign.net](http://www.primedesign.net)

# CONTENTS OVERVIEW

## TWO CROSSBAR CONFIGURATION

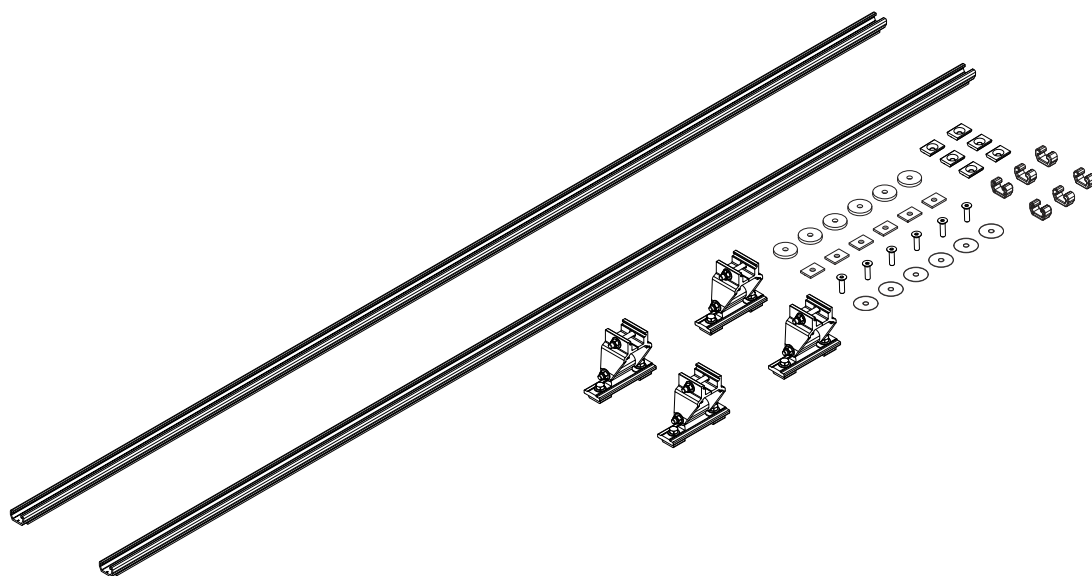

1—FBM-1014-BLK..... (Qty 1)  
Channels, 80.00" w/Hardware Kit

Channels 80" (2X)



 End Caps (4X)

 Brackets (4X)

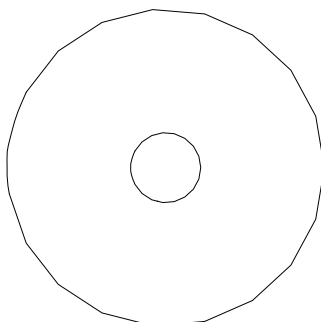

Nylon Washer (6X)

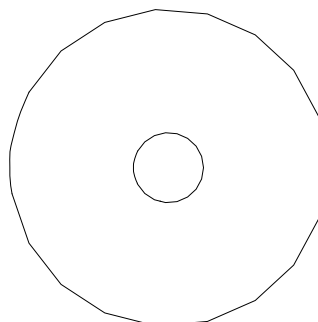

Foam Gasket (6X)

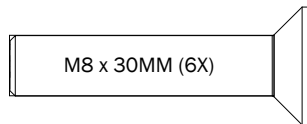

M8 x 30MM (6X)

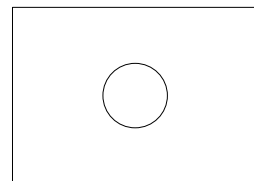

Foam Pad (6X)



Anti-Seize (1X)

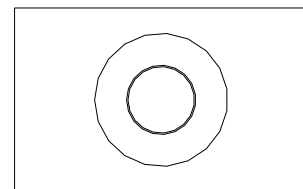

Flex Channel Connector (6X)

2—Crossbars (shown for illustrative purposes only)  
Ordered separately

ErgoRack, Gen4

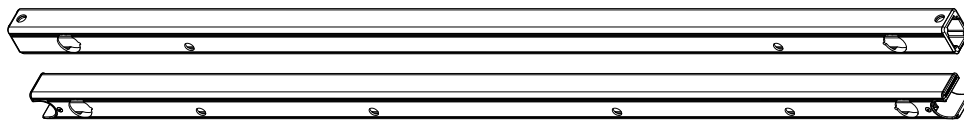

AluRack

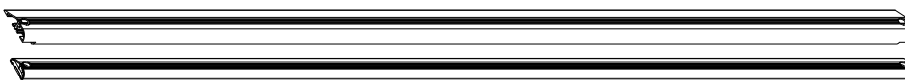

# L2H1 FBM ASSEMBLY SEQUENCE

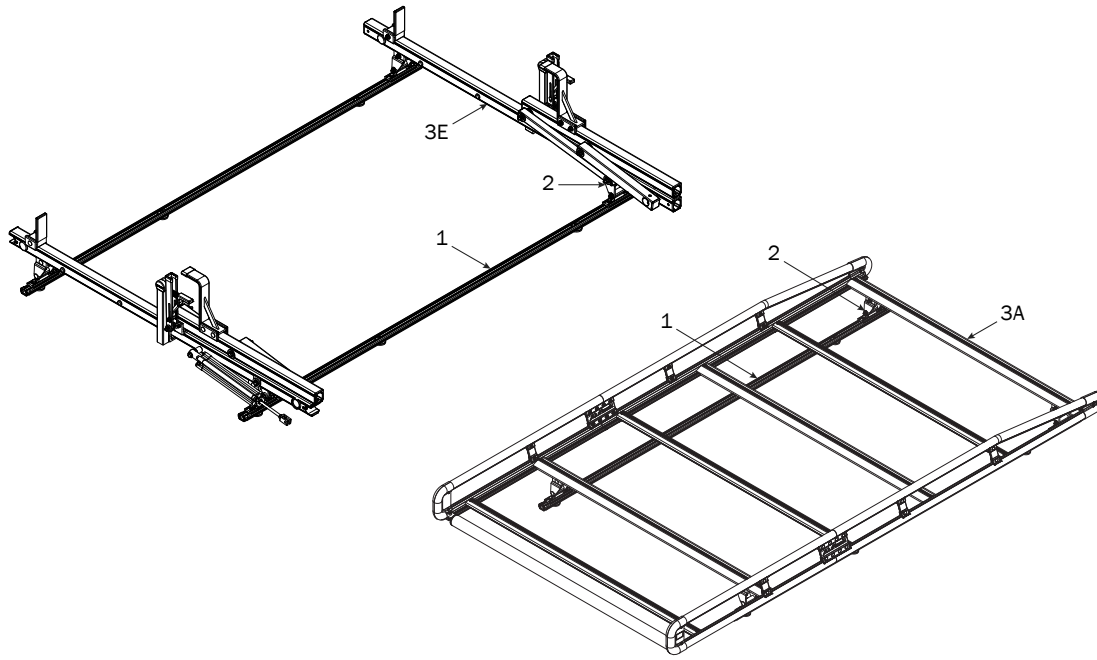

NOTE: Base, Rotation, Crossbar, and Side Rail features are shown for illustrative purposes only. These features are not included with this Base Mounting Kit, and must be purchased separately.

## FLEX CHANNELS

**1.1** Attach the Foam Pads and slide the Connectors into the Channels. Position the Connectors as shown below in Fig. 1

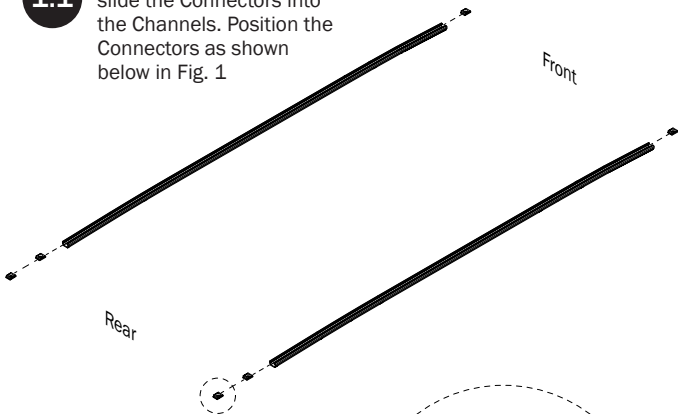

**1.2**

Attach Foam Pads to the Connector bottom, then slide the Channel Connectors into the Channels as shown

Fig. 1



**1.3** Apply Anti-Seize to six M8 x 30MM Screws, and fasten the Channels into the roof Channel grooves.

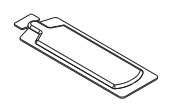

Anti-Seize  
Must apply Anti-Seize Compound and torque to specified value.

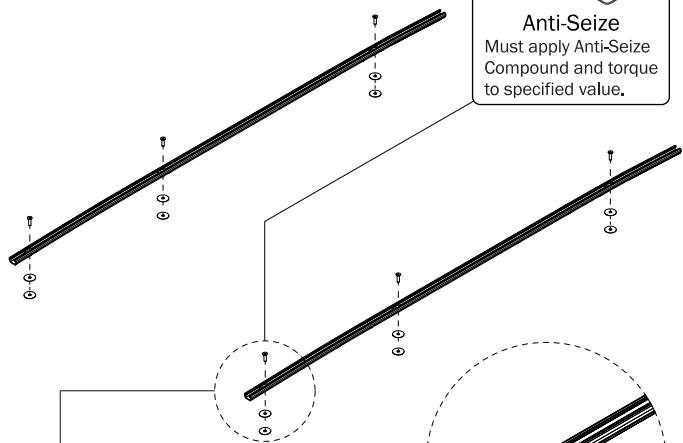

**1.4** Assemble fasteners onto factory roof rail mounting locations.

**1.5**

Torque to 150 in-lbs.

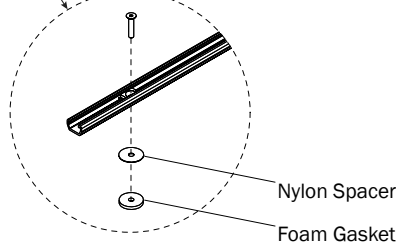

**MOUNTING BRACKETS**

- 2.1** Loosen the bolts indicated below, then slide Crossbar Mounting Brackets into each of the Channels, and attach the Channel Caps

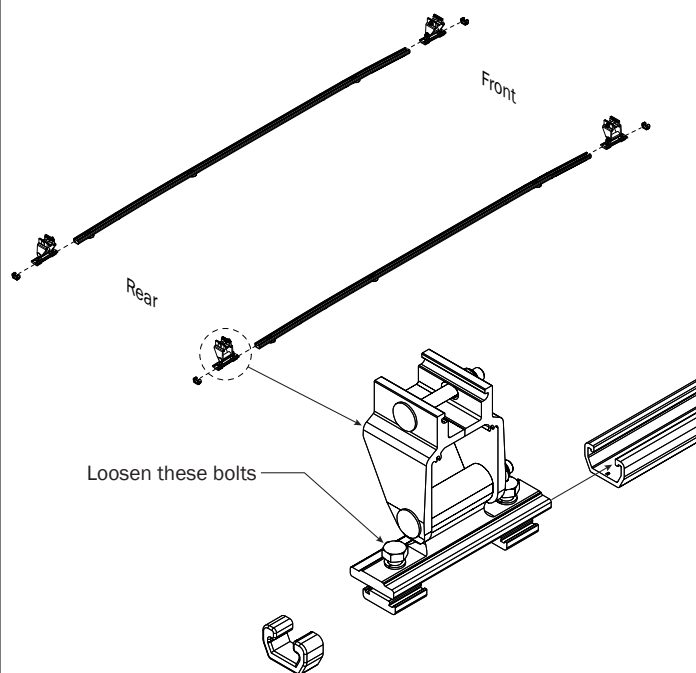

- 2.2** Set to distances shown below. Do not torque the Crossbar Mounting Brackets until Steps 3.3–3.4. Finger-tighten them into designated dimension to hold them in place, then proceed to your Feature (FEA) Assembly Manual.

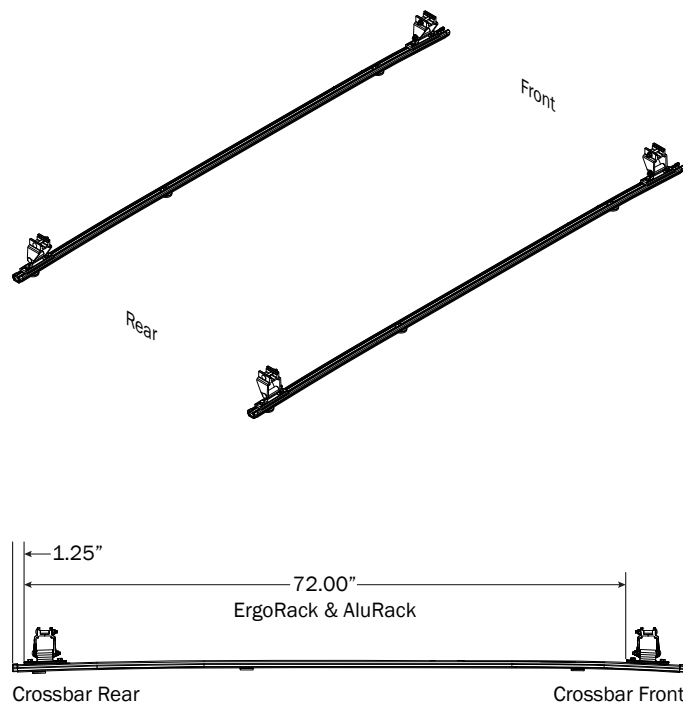

Do not mount the Crossbars to this FBM system at this time.

Refer to the respective FEA or AR Assembly Manual(s) included with your chosen rack configuration features. Depending upon the features chosen, you may need to perform a complete feature assembly onto the Crossbars or Side Rails as noted in that feature's Assembly Manual.

**WARNING:** Failure to position the Crossbars as shown in this FBM Assembly Manual may result in damage to the sliding door and/or ladder rack.

**NOTE:** Crossbars, Side Rails, Base, Clamp Down, or Rotation features are not included in this FBM kit, and must be purchased separately. To purchase applicable features and accessories, please contact your authorized distributor, or a Prime Design Sales & Service Representative.

## CROSSBARS (ERGORACK)

Shown with LH Base, and RH Rotation for illustrative purposes only

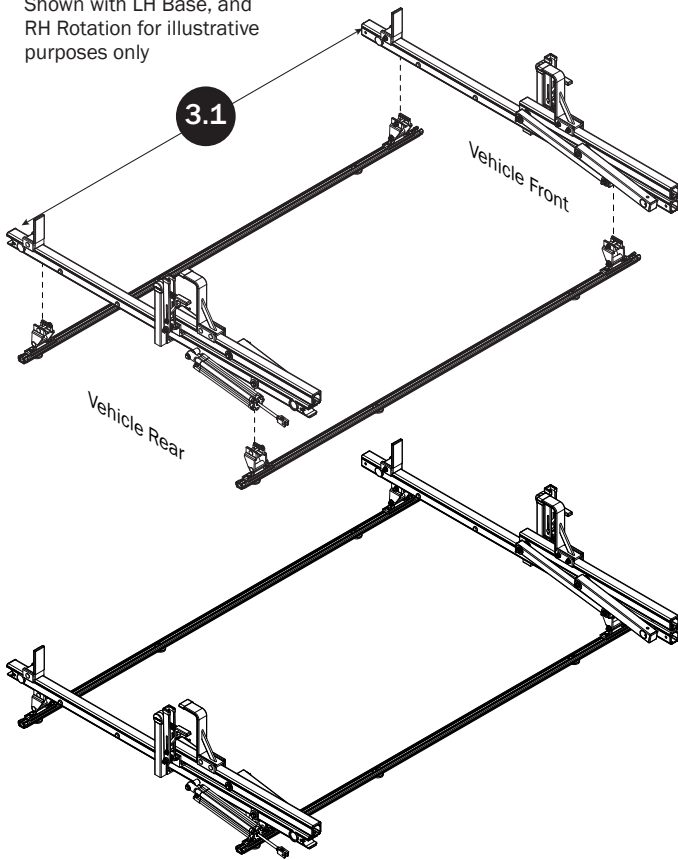

## CROSSBAR ADJUSTMENT

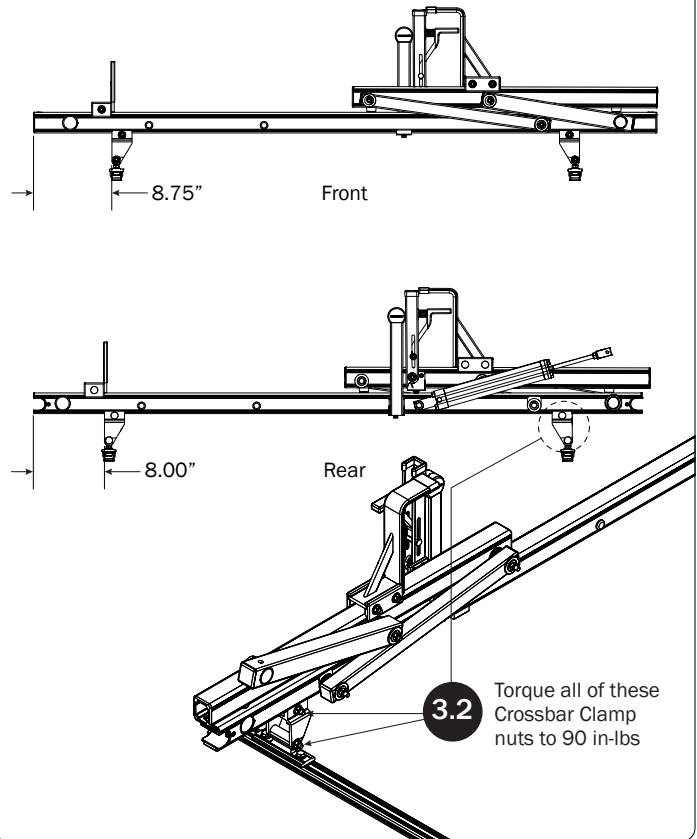

3.3

Verify the specified distance from the ends of both Mounting Bracket to the ends of both Channels.

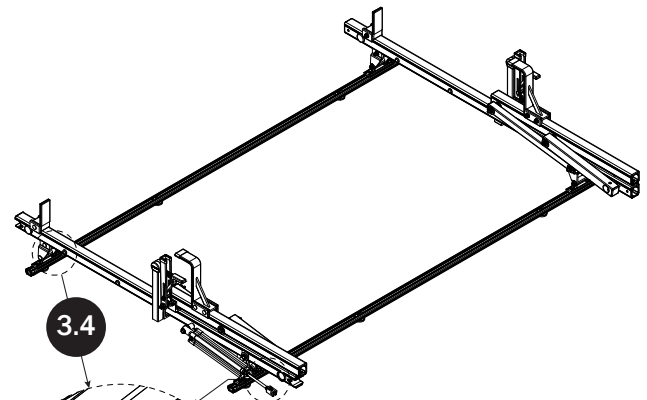
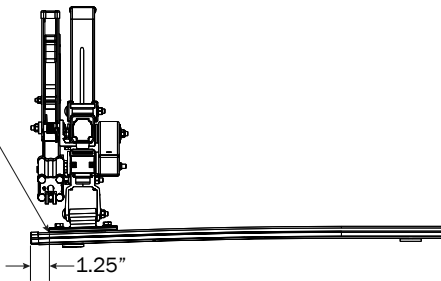

Torque only the Rear Crossbar Mounting Bracket bolts to 90 in-lbs at this time.

The Front Crossbar Mounting Brackets will be torqued to specification when designated in the respective Feature (FEA) Assembly Manual.

**CROSSBARS (ALURACK)**

Shown with L2H1 AluRack  
for illustrative purposes only

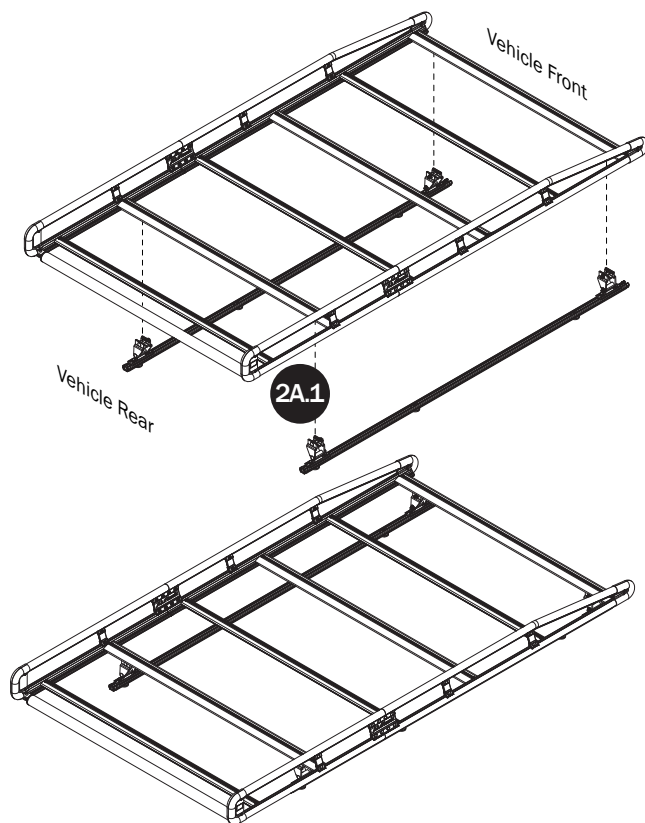
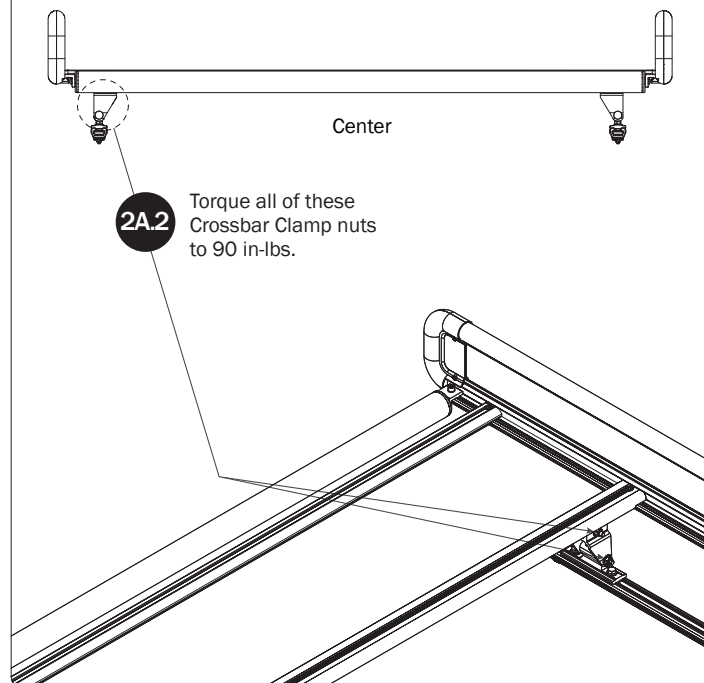
**CROSSBAR  
ADJUSTMENT**

Torque all of these  
Crossbar Clamp nuts  
to 90 in-lbs.

**2A.3**

Verify the specified  
distance from the  
ends of both Mounting  
Bracket to the ends of  
both Channels.

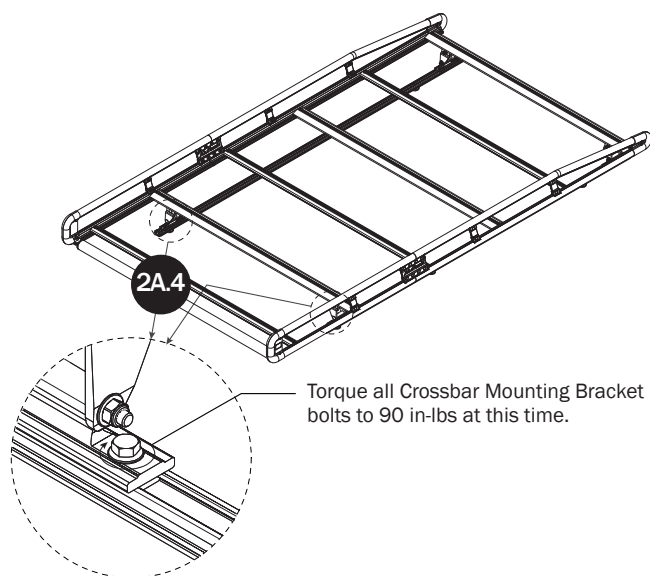
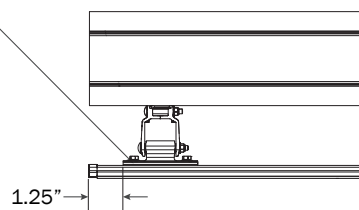

Torque all Crossbar Mounting Bracket  
bolts to 90 in-lbs at this time.

Page Intentionally Left Blank

